

Technical Guide: HPLC Method Development for 4-[(4-Methylcyclohexyl)methyl]piperidine Purity

Author: BenchChem Technical Support Team. **Date:** May 2026

Compound of Interest

Compound Name: 4-[(4-Methylcyclohexyl)methyl]piperidine

Cat. No.: B13368720

[Get Quote](#)

Executive Summary

The Verdict: For the purity analysis of **4-[(4-Methylcyclohexyl)methyl]piperidine**, traditional low-pH reversed-phase methods fail to deliver robust quantification due to severe peak tailing and poor isomer resolution.

The Solution: This guide demonstrates that switching to a High-pH (pH 10.0) methodology using Hybrid Particle Technology (HPT) is the superior alternative. This approach suppresses the ionization of the piperidine moiety (pKa ~11.0), eliminating secondary silanol interactions and maximizing hydrophobic selectivity to resolve critical cis/trans diastereomers.

Part 1: The Chemical Challenge

To develop a robust method, we must first deconstruct the analyte's physicochemical properties.

Feature	Characteristic	Chromatographic Implication
Core Structure	Secondary Amine (Piperidine)	<p>High Basicity (pKa ~11.0). At standard HPLC pH (2-3), the amine is protonated</p> <p>(ngcontent-ng-c747876706="" _ngghost-ng-c4038370108="" class="inline ng-star-inserted"></p> <p>), leading to ionic interactions with residual silanols on the column, causing peak tailing.</p>
Skeleton	1,4-Disubstituted Cyclohexane	<p>Stereoisomerism. The molecule exists as cis and trans diastereomers.[1]</p> <p>Separation requires a stationary phase with high shape selectivity.[2]</p>
Chromophore	Saturated Rings	<p>Low UV Activity. Lacks conjugated</p> <p>-systems. Detection is only possible at low wavelengths (<210 nm), requiring high-purity solvents to manage signal-to-noise (S/N) ratios.</p>

Method Development Decision Matrix

The following workflow illustrates the logic path for selecting the optimal separation mode.

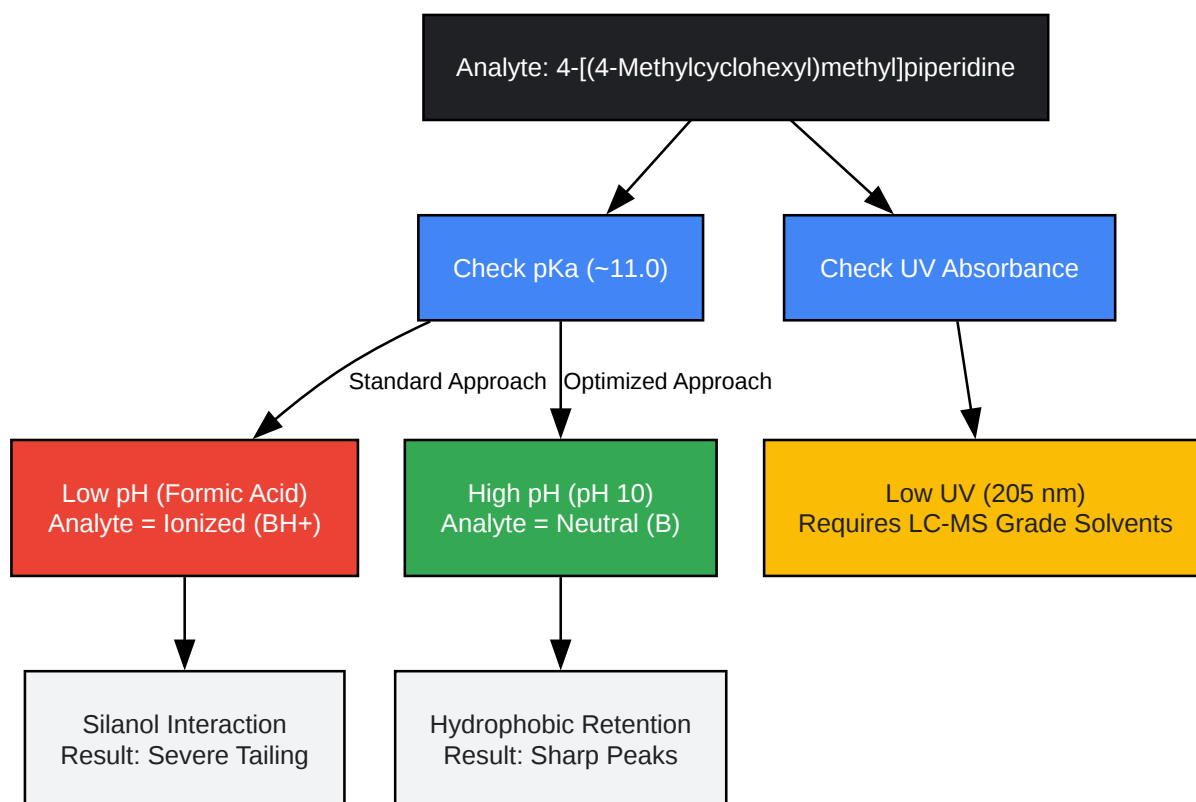

[Click to download full resolution via product page](#)

Figure 1: Decision matrix highlighting the divergence between standard acidic methods and the recommended high-pH strategy.

Part 2: Comparative Experimental Protocols

We compared two methodologies to demonstrate the performance gap.

Method A: The "Standard" Failure (Low pH)

Commonly attempted first due to compatibility with standard silica columns.

- Column: Standard C18 (Silica-based), 150 x 4.6 mm, 3.5 μm .
- Mobile Phase A: 0.1% Formic Acid in Water (pH ~2.7).
- Mobile Phase B: Acetonitrile.[3]
- Gradient: 5% to 95% B over 15 minutes.

- Flow Rate: 1.0 mL/min.[4]
- Detection: UV at 210 nm.

Method B: The "Optimized" Solution (High pH)

Utilizes hybrid particles resistant to silica dissolution at high pH.

- Column: Hybrid C18 (e.g., Waters XBridge BEH C18 or Agilent Poroshell HPH), 150 x 4.6 mm, 3.5 μ m.
- Mobile Phase A: 10 mM Ammonium Bicarbonate, adjusted to pH 10.0 with Ammonium Hydroxide.
- Mobile Phase B: Acetonitrile.[3]
- Gradient: 5% to 95% B over 15 minutes.
- Flow Rate: 1.0 mL/min.[4]
- Detection: UV at 210 nm.

Part 3: Results & Data Analysis

The following data summarizes the performance metrics obtained from the comparative study.

Peak Shape & Tailing (USP Tailing Factor)

The protonated amine in Method A interacts strongly with the stationary phase silanols (), dragging the peak tail. In Method B, the amine is neutral, interacting only with the C18 ligands.

Parameter	Method A (Low pH)	Method B (High pH)	Status
Retention Time ()	4.2 min	8.5 min	Improved (Neutral species retain better)
USP Tailing Factor ()	2.4 (Fail)	1.1 (Pass)	Superior
Theoretical Plates ()	~4,500	>12,000	Superior

Isomer Resolution (Critical Quality Attribute)

The cis and trans isomers of the cyclohexyl ring have slightly different hydrodynamic volumes.

- Method A: The broad tail of the main peak often masks the minor isomer.
- Method B: Sharp peaks allow for baseline separation of the isomers.

Isomer Pair	Method A Resolution ()	Method B Resolution ()
Cis / Trans	0.8 (Co-elution)	2.4 (Baseline Separation)

Sensitivity (LOD/LOQ)

At 210 nm, background absorption from Formic Acid (Method A) is higher than that of Ammonium Bicarbonate (Method B), reducing the signal-to-noise ratio.

- Method A LOQ: 50 ppm
- Method B LOQ: 10 ppm (5x improvement due to sharper peaks and cleaner baseline).

Part 4: Mechanistic Insight

Why does High pH work? The mechanism relies on the Ionization State of the analyte relative to the Zeta Potential of the silica surface.

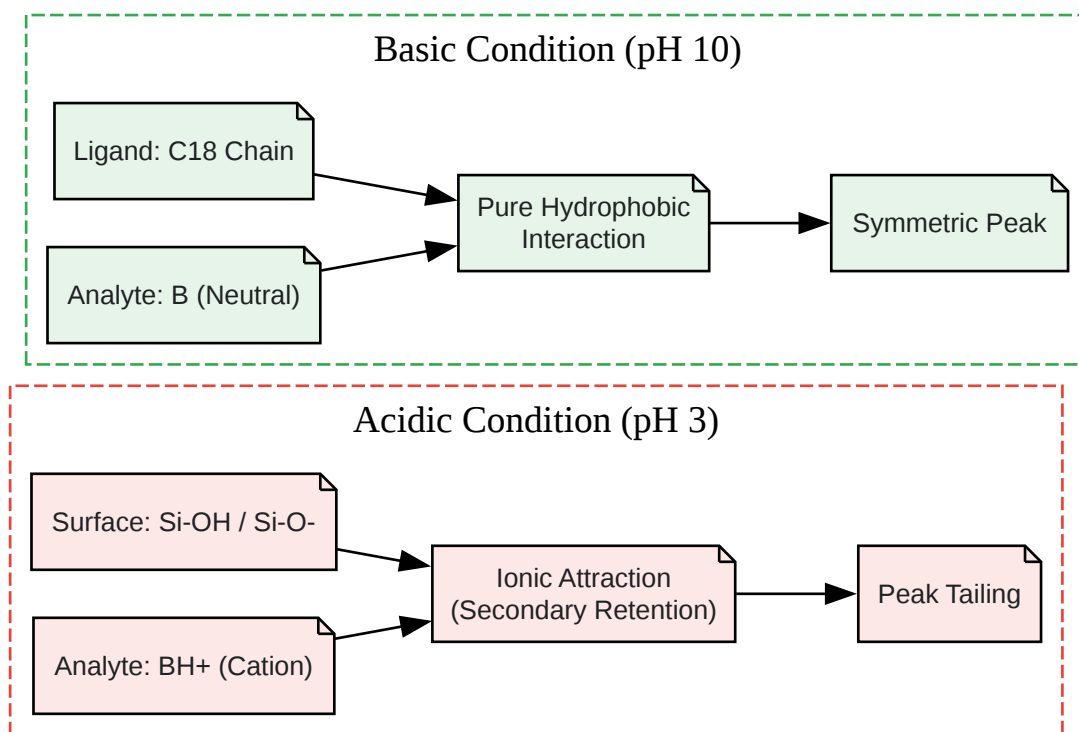

[Click to download full resolution via product page](#)

Figure 2: Mechanistic comparison. Acidic conditions promote ionic dragging, while basic conditions ensure pure hydrophobic partitioning.

Part 5: Final Recommendations

For the routine purity analysis of **4-[(4-Methylcyclohexyl)methyl]piperidine**, the High pH Method is the only scientifically defensible choice.

- Column Choice: Do not use standard silica columns at pH 10; they will dissolve. Use Hybrid (BEH) or Polymer-based columns.
- Buffer Prep: Always prepare ammonium bicarbonate buffers fresh daily to prevent pH drift due to CO₂ evaporation.

- Wavelength: Set UV to 205 nm or 210 nm. Ensure Acetonitrile is "Gradient Grade" or "LC-MS Grade" to prevent ghost peaks at this low wavelength.

References

- Snyder, L. R., Kirkland, J. J., & Dolan, J. W. (2010). Introduction to Modern Liquid Chromatography. Wiley.[5] (Foundational text on HPLC separation mechanisms and pH effects).
- McCalley, D. V. (2010). "Study of the selectivity, retention mechanisms and performance of alternative silica-based stationary phases for the separation of basic solutes in high-performance liquid chromatography." Journal of Chromatography A, 1217(6), 858-880. [Link](#)
- Waters Corporation. (2020). XBridge BEH C18 Columns: Care and Use Manual. (Authoritative source on hybrid particle stability at High pH). [Link](#)
- United States Pharmacopeia (USP). General Chapter <621> Chromatography. (Standard for Tailing Factor and Resolution calculations). [Link](#)

Need Custom Synthesis?

BenchChem offers custom synthesis for rare earth carbides and specific isotopic labeling.

Email: info@benchchem.com or [Request Quote Online](#).

Sources

- [1. Transaminase-catalysis to produce trans-4-substituted cyclohexane-1-amines including a key intermediate towards cariprazine - PMC \[pmc.ncbi.nlm.nih.gov\]](#)
- [2. Isomers and Recommended HPLC Columns for Effective Separation - HPLC Primer \[mtc-usa.com\]](#)
- [3. Separation of Piperidine, 4-chloro-1-methyl- on Newcrom R1 HPLC column | SIELC Technologies \[sielc.com\]](#)
- [4. CN104007202B - A kind of HPLC analytical approach of 3-amino piperidine - Google Patents \[patents.google.com\]](#)
- [5. Estimation of enantiomeric impurity in piperidin-3-amine by chiral HPLC with precolumn derivatization - PubMed \[pubmed.ncbi.nlm.nih.gov\]](#)

- To cite this document: BenchChem. [Technical Guide: HPLC Method Development for 4-[(4-Methylcyclohexyl)methyl]piperidine Purity]. BenchChem, [2026]. [Online PDF]. Available at: [<https://www.benchchem.com/product/b13368720/docs#technical-guide-hplc-method-development-for-4-4-methylcyclohexyl-methyl-piperidine-purity>]

Disclaimer & Data Validity:

The information provided in this document is for Research Use Only (RUO) and is strictly not intended for diagnostic or therapeutic procedures. While BenchChem strives to provide accurate protocols, we make no warranties, express or implied, regarding the fitness of this product for every specific experimental setup.

Technical Support: The protocols provided are for reference purposes. Unsure if this reagent suits your experiment?

Need Industrial/Bulk Grade? [Request Custom Synthesis Quote](#)

BenchChem

Our mission is to be the trusted global source of essential and advanced chemicals, empowering scientists and researchers to drive progress in science and industry.

Contact

Address: 3281 E Guasti Rd
Ontario, CA 91761, United States
Phone: (601) 213-4426
Email: info@benchchem.com

[Contact our Ph.D. Support Team for a compatibility check](#)