

Technical Support Center: Z-Ala-Phe-OH Peptide Synthesis

Author: BenchChem Technical Support Team. **Date:** May 2026

Compound of Interest

Compound Name: Z-Ala-Phe-OH

CAS No.: 2768-53-8

Cat. No.: B1336518

[Get Quote](#)

Welcome to the technical support center for **Z-Ala-Phe-OH** peptide synthesis. This guide is designed for researchers, scientists, and drug development professionals to navigate the common challenges encountered during the synthesis of this dipeptide. Here, we provide in-depth troubleshooting advice and frequently asked questions to ensure the successful synthesis of your target peptide with high purity and yield.

I. Frequently Asked Questions (FAQs)

Q1: What are the most common side reactions observed during the synthesis of Z-Ala-Phe-OH?

The synthesis of **Z-Ala-Phe-OH**, typically involving the coupling of N-benzyloxycarbonyl-L-alanine (Z-Ala-OH) and L-phenylalanine (H-Phe-OH), is susceptible to two primary side reactions:

- Racemization of the Phenylalanine residue: This is the most critical side reaction, leading to the formation of the diastereomer, Z-Ala-D-Phe-OH. Phenylalanine is known to be prone to racemization during peptide coupling.[\[1\]](#)[\[2\]](#)

- N-acylurea formation: When using carbodiimide-based coupling reagents such as dicyclohexylcarbodiimide (DCC) or diisopropylcarbodiimide (DIC), a common side reaction is the formation of a stable N-acylurea byproduct.[3][4] This byproduct consumes the activated Z-Ala-OH, leading to lower yields of the desired dipeptide.

Q2: Why is Phenylalanine prone to racemization during peptide synthesis?

Phenylalanine is susceptible to racemization primarily through the formation of an oxazolone (also known as an azlactone) intermediate.[1][5] This occurs when the carboxyl group of Z-Ala-OH is activated for coupling. The activated intermediate can cyclize to form a planar oxazolone. The α -proton of the Phenylalanine becomes acidic in this intermediate and can be abstracted by a base, leading to a loss of stereochemistry. Reprotonation can then occur from either face of the planar intermediate, resulting in a mixture of L- and D-phenylalanine residues in the final peptide.

Q3: What is the Z (benzyloxycarbonyl) protecting group and is it stable during the coupling reaction?

The Z-group, or benzyloxycarbonyl group, is a common amine protecting group in peptide synthesis.[6] It is generally stable under the neutral or mildly acidic conditions used for many coupling reactions. However, it is sensitive to catalytic hydrogenation (e.g., H_2/Pd), strong acids like HBr in acetic acid, and sodium in liquid ammonia, which are the methods used for its removal.[6][7] During a standard carbodiimide-mediated coupling of Z-Ala-OH to H-Phe-OH, the Z-group on the alanine residue is stable and does not typically lead to side reactions itself.

II. Troubleshooting Guide

Issue 1: Presence of a Diastereomeric Impurity (Z-Ala-D-Phe-OH) in the Final Product

Symptoms:

- Your HPLC or LC-MS analysis shows a second peak with the same mass as your desired product, which is difficult to separate.

- Chiral analysis confirms the presence of the D-Phe isomer.

Root Cause Analysis:

Racemization of the phenylalanine residue during the coupling step is the most likely cause.

This is often exacerbated by:

- Excessive activation time: Allowing the activated Z-Ala-OH to stand for too long before adding H-Phe-OH increases the opportunity for oxazolone formation and subsequent racemization.
- High temperatures: Elevated temperatures can accelerate the rate of racemization.
- Use of strong bases: Tertiary amines, often used to neutralize salts, can promote the abstraction of the α -proton from the oxazolone intermediate.[8]

Troubleshooting Workflow:



[Click to download full resolution via product page](#)

Caption: Troubleshooting workflow for diastereomeric impurity.

Mitigation Strategies & Protocols:

1. In-Situ Activation with Additives:

The most effective way to suppress racemization is to use coupling additives that react with the activated Z-Ala-OH to form a less reactive, but still aminolysis-susceptible, intermediate. This intermediate is less prone to cyclizing into an oxazolone.

- Recommended Additives:
 - 1-Hydroxybenzotriazole (HOBt): The classic and still widely used racemization suppressant.[9]

- Ethyl 2-cyano-2-(hydroxyimino)acetate (OxymaPure®): A highly effective and non-explosive alternative to HOBt.

Protocol: DCC/HOBt Mediated Coupling of Z-Ala-OH and H-Phe-OH

- Dissolve Reactants: In a round-bottom flask, dissolve Z-Ala-OH (1 equivalent) and H-Phe-OH (1 equivalent) in a suitable aprotic solvent (e.g., DMF or DCM).
- Add HOBt: Add 1-hydroxybenzotriazole (HOBt) (1.1 equivalents) to the solution and stir until it is fully dissolved.
- Cool the Reaction: Cool the reaction mixture to 0 °C in an ice bath.
- Add DCC: Add N,N'-dicyclohexylcarbodiimide (DCC) (1.1 equivalents) to the cold, stirred solution.
- Reaction: Allow the reaction to warm to room temperature and stir for 12-24 hours.
- Work-up:
 - The byproduct, dicyclohexylurea (DCU), will precipitate out of the solution. Filter the reaction mixture to remove the DCU.^[10]
 - Wash the filtrate with a dilute acid (e.g., 1N HCl) to remove any unreacted amine, followed by a dilute base (e.g., 5% NaHCO₃) to remove unreacted carboxylic acid, and finally with brine.
 - Dry the organic layer over anhydrous sodium sulfate, filter, and concentrate under reduced pressure.
 - Purify the crude product by recrystallization or column chromatography.

2. Control of Reaction Temperature and Time:

- Low Temperature: Perform the coupling reaction at low temperatures (starting at 0 °C) to minimize the rate of racemization.^[3]

- Minimize Pre-activation: If pre-activation of Z-Ala-OH is necessary, keep the time between activation and the addition of H-Phe-OH as short as possible.

Quantitative Data on Racemization Suppression:

Coupling Method	Additive	Temperature (°C)	% D-Phe Isomer (Typical)
DCC	None	25	> 10%
DCC	HOBt	0 -> 25	< 2%
EDC/HOBt	HOBt	0 -> 25	< 1%

Note: The extent of racemization can vary depending on the specific reaction conditions and solvent used.

Issue 2: Low Yield and Presence of an Insoluble Byproduct

Symptoms:

- The yield of your desired **Z-Ala-Phe-OH** is significantly lower than expected.
- A white, insoluble precipitate is formed during the reaction, which is not your product.

Root Cause Analysis:

When using carbodiimides like DCC or DIC, the highly reactive O-acylisourea intermediate can rearrange to form a stable, unreactive N-acylurea.^{[3][11]} This side reaction consumes the activated amino acid and the coupling reagent, thereby reducing the yield of the desired peptide.

Reaction Scheme: N-Acylurea Formation

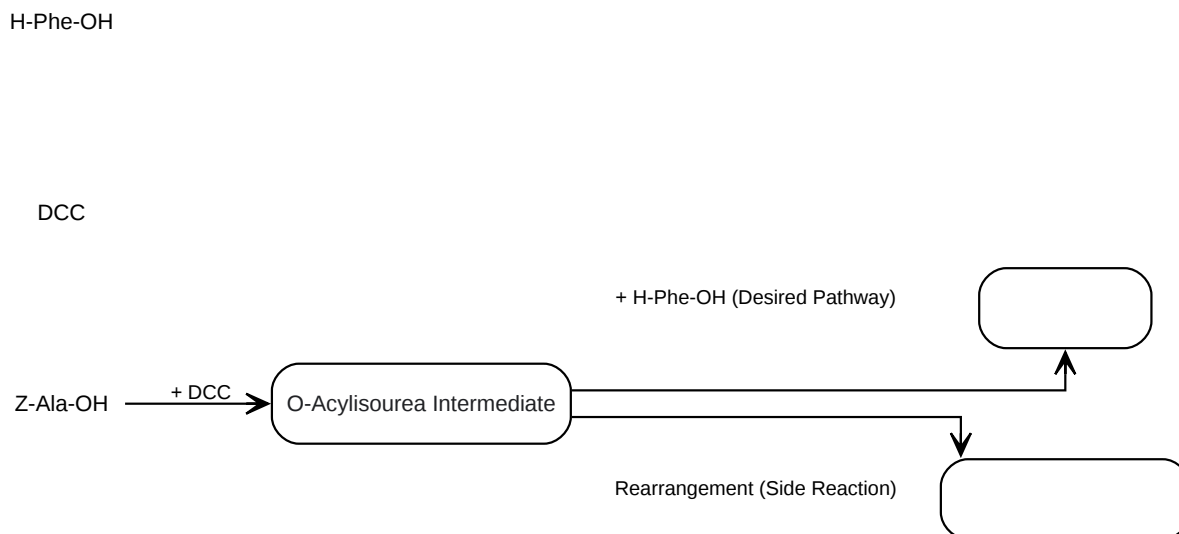

[Click to download full resolution via product page](#)

Caption: Competing pathways of the O-acylisourea intermediate.

Mitigation Strategies:

The strategies to prevent N-acylurea formation are similar to those for suppressing racemization, as they both involve trapping the reactive O-acylisourea intermediate.

- Use of Additives: HOBt or OxymaPure® will react with the O-acylisourea intermediate to form an active ester that is less prone to rearrangement. The protocol provided above for DCC/HOBt coupling is also effective in minimizing N-acylurea formation.
- Solvent Choice: Using solvents with low dielectric constants, such as dichloromethane (DCM) or chloroform, can help to minimize this side reaction.[4]
- Temperature Control: Maintaining a low reaction temperature (0 °C) during the addition of the carbodiimide can also help to reduce the rate of rearrangement.[3]

III. Summary of Best Practices for Z-Ala-Phe-OH Synthesis

To maximize the yield and purity of your **Z-Ala-Phe-OH** dipeptide, adhere to the following best practices:

- Always use a racemization suppressing additive, such as HOBt or OxymaPure®, when using carbodiimide coupling reagents.
- Control the reaction temperature, starting at 0 °C and allowing the reaction to slowly warm to room temperature.
- Minimize the time between the activation of Z-Ala-OH and the addition of H-Phe-OH.
- Choose an appropriate solvent, with DCM often being a good choice to minimize N-acylurea formation.
- Carefully monitor the reaction progress using a suitable analytical technique like TLC or LC-MS to determine the optimal reaction time.

By understanding the underlying mechanisms of these common side reactions and implementing the recommended troubleshooting strategies, you can significantly improve the outcome of your **Z-Ala-Phe-OH** peptide synthesis.

IV. References

- Racemization of Amino Acids in Solid-Phase Peptide Synthesis Investigated by Capillary Electrophoresis. (1995). *Analytical Chemistry*, 67(13), 2268–2273. [[Link](#)]
- Racemization during SPPS coupling step. (n.d.). ResearchGate. Retrieved January 29, 2026, from [[Link](#)]
- Peptides Notes. (n.d.). Alchemyst. Retrieved January 29, 2026, from [[Link](#)]
- Goodman, M., & Glaser, C. (1969). Racemization in Oxazolone Reactions. *The Journal of Organic Chemistry*, 34(3), 589–593. [[Link](#)]
- Han, Y., et al. (1997). Minimization of cysteine racemization during stepwise solid-phase peptide synthesis. *Journal of Peptide Research*, 49(4), 321-330. [[Link](#)]
- Ismail, I., et al. (2023). Epimerisation in Peptide Synthesis. *Molecules*, 28(17), 6301. [[Link](#)]

- Ashenhurst, J. (2019, February 15). Introduction to Peptide Synthesis. Master Organic Chemistry. [\[Link\]](#)
- Trant, J. (2021, March 12). Lecture 16 Protecting groups and racemization of Amino Acids [Video]. YouTube. [\[Link\]](#)
- Protecting Groups in Peptide Synthesis: A Detailed Guide. (n.d.). Synpeptide. Retrieved January 29, 2026, from [\[Link\]](#)
- Peptide racemization & Tautomerism: Advantage & difficulty & application of this idea for Ibuprofen. (2020, May 8). [Video]. YouTube. [\[Link\]](#)
- Amino Acid Derivatives for Peptide Synthesis. (n.d.). Aapptec. Retrieved January 29, 2026, from [\[Link\]](#)
- Aggregation, Racemization and Side Reactions in Peptide Synthesis. (n.d.). AAPPTEC. Retrieved January 29, 2026, from [\[Link\]](#)
- Kumar, A., et al. (2024). Oxazolone mediated peptide chain extension and homochirality in aqueous microdroplets. *Proceedings of the National Academy of Sciences*, 121(2), e2315924121. [\[Link\]](#)
- Izdebski, J., & Pełka, J. (1984). Formation of Optically Pure N-acyl-N,N'-dicyclohexylurea in N,N'-dicyclohexylcarbodiimide-mediated Peptide Synthesis. *International Journal of Peptide and Protein Research*, 24(1), 86-90. [\[Link\]](#)
- Suppression of alpha-carbon racemization in peptide synthesis based on a thiol-labile amino protecting group. (2019). *Nature Communications*, 10(1), 1-9. [\[Link\]](#)
- Rehman, M. M. U., et al. (2018). Side reactions in peptide synthesis: An overview. *International Journal of Pharmaceutical Research & Technology*, 10, 1-10. [\[Link\]](#)
- Ashenhurst, J. (2018, June 7). Protecting Groups For Amines: Carbamates. Master Organic Chemistry. [\[Link\]](#)
- Ramazani, A., et al. (2016). Synthesis of N-acylurea derivatives from carboxylic acids and N,N'-dialkyl carbodiimides in water. *Journal of Chemical Sciences*, 128(2), 261-266. [\[Link\]](#)

- Monitoring action readiness of coupling reagent carbodiimide in aqueous solutions. (2009). *Analytical Biochemistry*, 385(2), 241-246. [[Link](#)]
- Epimerization by oxazolone formation. (n.d.). ResearchGate. Retrieved January 29, 2026, from [[Link](#)]
- The Catalyst's Companion: N,N'-Dicyclohexylcarbodiimide (DCC) in Action. (2023). *ChemistrySelect*, 8(42), e202303351. [[Link](#)]
- Practical N-to-C peptide synthesis with minimal protecting groups. (2022). *Nature Communications*, 13(1), 1-9. [[Link](#)]
- Peptide Synthesis - Carbodiimide Mediated Coupling. (2025, June 3). [Video]. YouTube. [[Link](#)] (Note: A placeholder link is used as the original may not be stable. The content is based on general knowledge of the topic).
- Synthesis of N-acylurea derivatives from carboxylic acids and N,N'-dialkyl carbodiimides in water. (2016). *Journal of Chemical Sciences*, 128(2), 261-266. [[Link](#)]
- Carbodiimides and Additives. (2021, May 19). Aapptec. Retrieved January 29, 2026, from [[Link](#)]

Need Custom Synthesis?

BenchChem offers custom synthesis for rare earth carbides and specific isotopic labeling.

Email: info@benchchem.com or [Request Quote Online](#).

Sources

- 1. pdf.benchchem.com [pdf.benchchem.com]
- 2. alchemyst.co.uk [alchemyst.co.uk]
- 3. bachem.com [bachem.com]
- 4. ias.ac.in [ias.ac.in]
- 5. mdpi.com [mdpi.com]

- [6. Protecting Groups in Peptide Synthesis: A Detailed Guide - Creative Peptides \[creative-peptides.com\]](#)
- [7. masterorganicchemistry.com \[masterorganicchemistry.com\]](#)
- [8. researchgate.net \[researchgate.net\]](#)
- [9. peptide.com \[peptide.com\]](#)
- [10. thieme-connect.com \[thieme-connect.com\]](#)
- [11. peptide.com \[peptide.com\]](#)
- To cite this document: BenchChem. [Technical Support Center: Z-Ala-Phe-OH Peptide Synthesis]. BenchChem, [2026]. [Online PDF]. Available at: [\[https://www.benchchem.com/product/b1336518/docs#technical-support-center-z-ala-phe-oh-peptide-synthesis\]](https://www.benchchem.com/product/b1336518/docs#technical-support-center-z-ala-phe-oh-peptide-synthesis)

Disclaimer & Data Validity:

The information provided in this document is for Research Use Only (RUO) and is strictly not intended for diagnostic or therapeutic procedures. While BenchChem strives to provide accurate protocols, we make no warranties, express or implied, regarding the fitness of this product for every specific experimental setup.

Technical Support: The protocols provided are for reference purposes. Unsure if this reagent suits your experiment?

Need Industrial/Bulk Grade? [Request Custom Synthesis Quote](#)

BenchChem

Our mission is to be the trusted global source of essential and advanced chemicals, empowering scientists and researchers to drive progress in science and industry.

Contact

Address: 3281 E Guasti Rd

Ontario, CA 91761, United States

Phone: (601) 213-4426

Email: info@benchchem.com

Contact our Ph.D. Support Team for a compatibility check