

Introduction: The Analytical Challenge of N-Allyl Phenethylamines

Author: BenchChem Technical Support Team. **Date:** April 2026

Compound of Interest

Compound Name: *[1-(4-Methoxyphenyl)ethyl](prop-2-EN-1-YL)amine*

Cat. No.: *B13345981*

[Get Quote](#)

N-allyl phenethylamines represent a class of compounds of significant interest to researchers in medicinal chemistry, pharmacology, and forensic science. As structural analogs of neurotransmitters and a subclass of new psychoactive substances (NPS), their reliable identification is paramount. Mass spectrometry (MS), coupled with chromatographic separation techniques like Gas Chromatography (GC) and Liquid Chromatography (LC), stands as the cornerstone for the structural elucidation of these molecules.[1][2] The definitive identification of these compounds can be challenging due to the high degree of structural similarity among analogs.[3]

This guide, written from the perspective of a Senior Application Scientist, provides an in-depth exploration of the fragmentation behavior of N-allyl phenethylamines under the two most prevalent ionization techniques: Electron Ionization (EI) and Electrospray Ionization (ESI). Understanding these fragmentation pathways is not merely an academic exercise; it is the fundamental basis for developing robust, reliable, and validated analytical methods for their detection and quantification. We will delve into the causality behind the observed fragmentation patterns and present self-validating experimental protocols designed for immediate application.

Pillar 1: Electron Ionization (EI) Fragmentation - The GC-MS Perspective

Electron Ionization is a "hard" ionization technique that imparts significant energy into the analyte, leading to extensive and often complex fragmentation patterns.[1] While this can make interpretation challenging, it also provides a rich fingerprint for structural elucidation, which is why GC-EI-MS remains a preferred method in many forensic laboratories.[1][4] For N-allyl phenethylamines, the fragmentation is dominated by cleavages dictated by the stability of the resulting radical cations.

The most predictable and diagnostically significant fragmentation pathway for phenethylamines under EI is the β -cleavage, which involves the breaking of the $C\alpha$ - $C\beta$ bond.[4][5] This cleavage is favored because it results in the formation of a highly stable, resonance-stabilized benzyl or tropylium cation and a nitrogen-containing immonium ion.

Key EI Fragmentation Pathways:

- β -Cleavage (Dominant Pathway): The primary fragmentation event is the cleavage of the bond between the α and β carbons relative to the phenyl ring. This yields two key fragments:
 - Tropylium Cation (m/z 91): The $C_7H_7^+$ ion, often observed as the base peak, is formed from the benzyl moiety after rearrangement to the stable tropylium structure. Its presence is a strong indicator of an unsubstituted phenethylamine backbone.
 - N-allyl Immonium Ion (m/z 70): The cleavage results in the formation of $[CH_2=NH-CH_2CH=CH_2]^+$. This ion is highly characteristic of the N-allyl substitution and is a crucial diagnostic marker.
- α -Cleavage: Cleavage of the $C\alpha$ -N bond is also possible, though typically less favorable than β -cleavage. This would result in the loss of the N-allyl amino group as a neutral radical, leaving a $C_8H_9^+$ fragment (m/z 105).
- Direct Allyl Loss: Cleavage of the N-allyl bond can occur, leading to the loss of an allyl radical ($\bullet C_3H_5$), resulting in an ion corresponding to the phenethylamine core, $[M-41]^+$.

The extensive fragmentation in EI can sometimes lead to a weak or absent molecular ion ($M^{+\bullet}$), making it crucial to identify these characteristic fragment ions for a confident identification.[6]

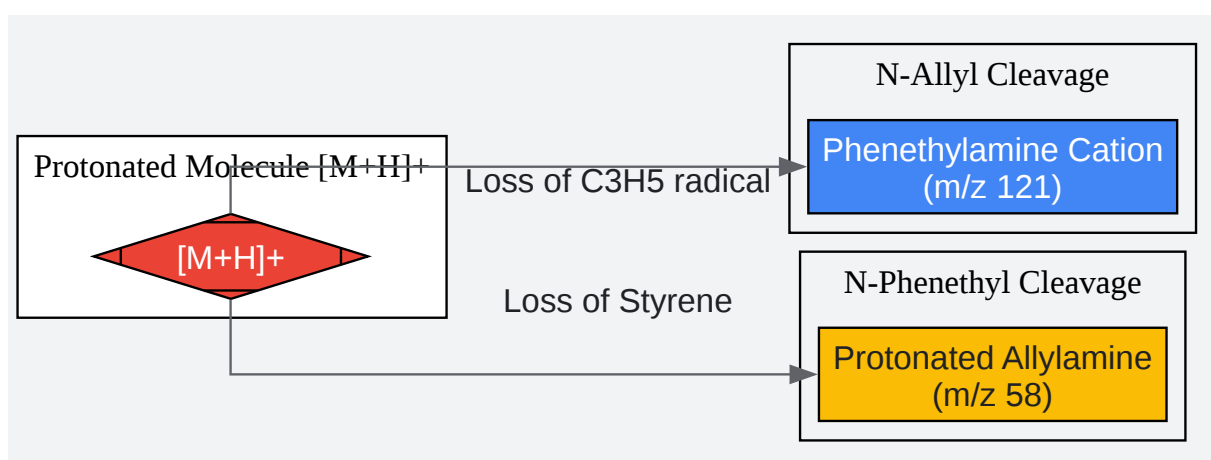
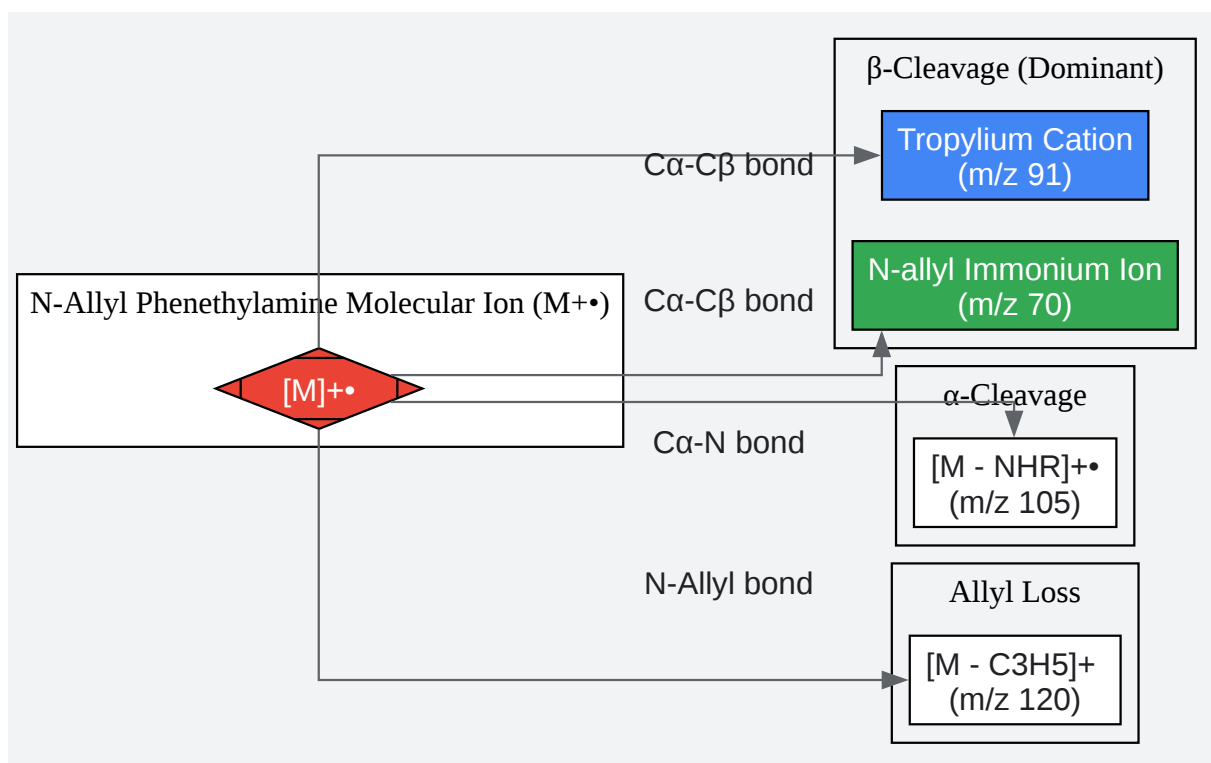

[Click to download full resolution via product page](#)

Caption: Primary ESI-CID fragmentation pathways for N-allyl phenethylamine.

Pillar 3: The Role of High-Resolution Mass Spectrometry (HRMS)

For both EI and ESI, high-resolution mass spectrometry (HRMS), often utilizing Time-of-Flight (TOF) or Orbitrap analyzers, offers a significant advantage over nominal mass instruments. [2] [7]HRMS provides the exact mass of precursor and fragment ions, typically with mass accuracy below 5 ppm. [1]This capability is crucial for:

- **Confirming Elemental Composition:** Exact mass measurements allow for the unambiguous determination of the elemental formula of each ion, confirming the identity of the molecule and its fragments.
- **Differentiating Isobars:** Many designer drugs are isomers, possessing the same nominal mass but different structures. HRMS can often distinguish between them based on subtle mass differences.
- **Non-Targeted Screening:** In forensic and drug development contexts, HRMS allows for data-independent acquisition (DIA), collecting fragmentation data on all ions present. This enables retrospective analysis of samples for new compounds as their structures become known. [2]

Data Presentation: Summary of Characteristic Ions

The following table summarizes the key diagnostic ions expected from the mass spectrometric analysis of a model compound, N-allyl phenethylamine (C₁₁H₁₅N, Monoisotopic Mass: 161.1204 Da).

Ionization	Precursor Ion (m/z)	Characteristic Fragment Ions (m/z)	Structural Origin / Neutral Loss
EI	161.12 (M ^{+•})	91.05	Tropylium Cation (β -cleavage)
70.07	N-allyl Immonium Ion (β -cleavage)		
120.11	[M - C ₃ H ₅] ⁺ (Loss of allyl radical)		
ESI-CID	162.13 ([M+H] ⁺)	121.10	[M+H - C ₃ H ₄] ⁺ (Loss of allene)
58.06	[C ₃ H ₅ NH ₃] ⁺ (Protonated allylamine)		

Experimental Protocols: A Self-Validating Workflow

A robust analytical method requires a well-defined and validated workflow, from sample preparation to data analysis. The following protocols are designed to be starting points for method development.

Workflow Overview

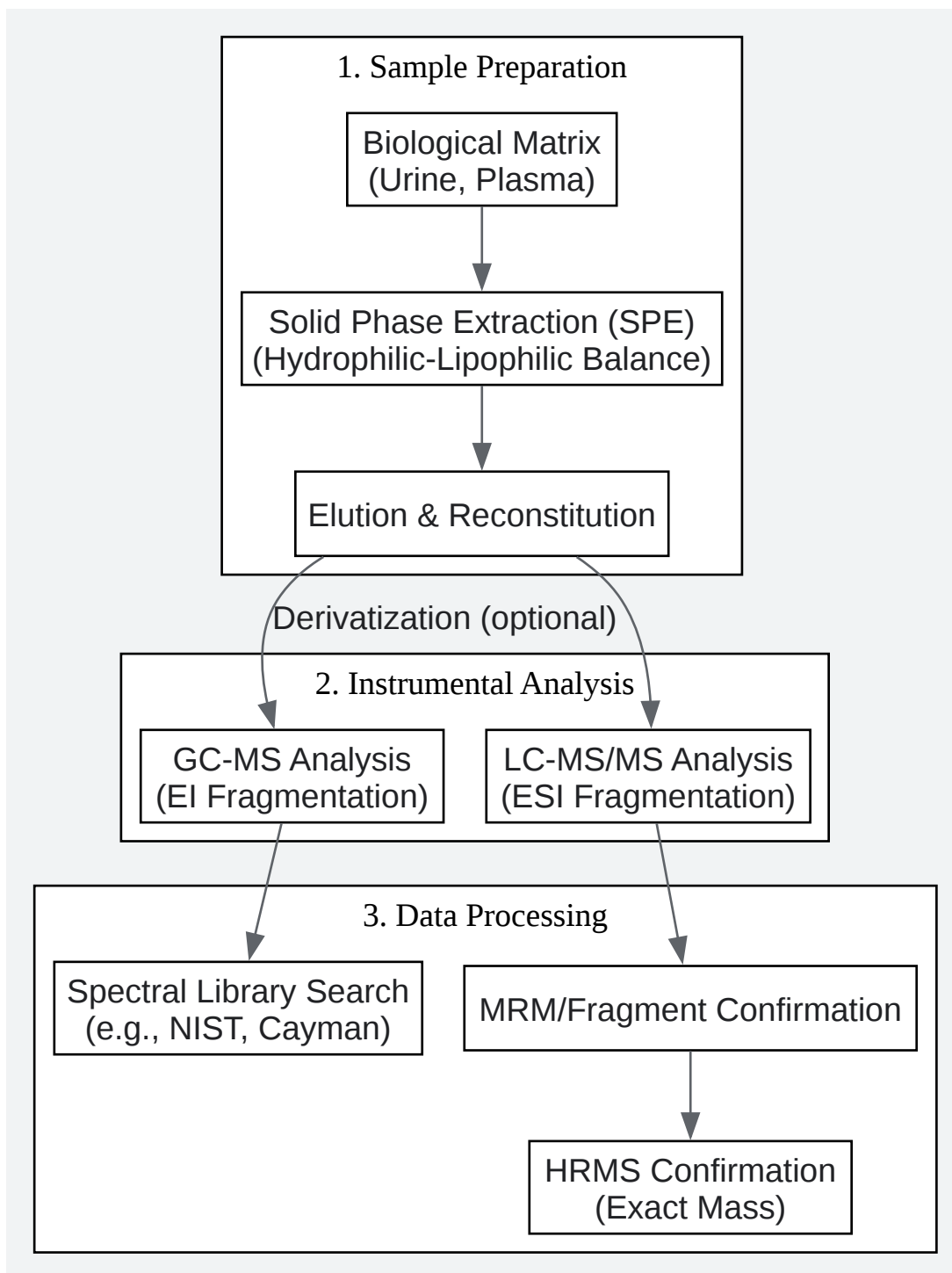

[Click to download full resolution via product page](#)

Caption: General analytical workflow for N-allyl phenethylamine analysis.

Protocol 1: GC-MS Analysis for Qualitative Identification

- Rationale: This protocol is optimized for structural confirmation using the rich fragmentation patterns generated by EI. Derivatization is often employed to improve chromatographic peak shape and thermal stability. [8]1. Sample Preparation (Liquid-Liquid Extraction):
 - To 1 mL of sample (e.g., urine), add an appropriate internal standard.
 - Add 500 μ L of 5.0 N aqueous NaOH to basify the sample to pH > 9. [9] * Add 2 mL of an organic solvent (e.g., hexane/isoamyl alcohol, 99:1 v/v). Vortex for 2 minutes.
 - Centrifuge at 3000 x g for 5 minutes.
 - Transfer the upper organic layer to a clean tube and evaporate to dryness under a gentle stream of nitrogen at 40°C.
- Derivatization (Optional but Recommended):
 - Reconstitute the dried extract in 50 μ L of ethyl acetate.
 - Add 50 μ L of N-methyl-N-(trifluoroacetyl)acetamide (MBTFA) or pentafluoropropionic anhydride (PFPA). [10][9] * Cap the vial and heat at 70°C for 20 minutes.
 - Cool to room temperature before injection.
- GC-MS Parameters:
 - GC System: Agilent 7890 or equivalent.
 - Column: HP-5MS (30 m x 0.25 mm, 0.25 μ m film thickness) or similar.
 - Injector: Splitless, 250°C.
 - Oven Program: Start at 70°C (hold 1 min), ramp to 280°C at 15°C/min, hold for 5 min.
 - Carrier Gas: Helium at 1.0 mL/min.
 - MS System: Agilent 5977 or equivalent.
 - Ionization: Electron Ionization (EI) at 70 eV.

- Source Temp: 230°C.
- Scan Range: m/z 40-550.
- Data Analysis: Compare the acquired spectrum against a reference standard and spectral libraries (e.g., NIST, SWGDRUG, Cayman Spectral Library) for a positive match. [\[11\]](#)

Protocol 2: LC-MS/MS for Quantitative Analysis

- Rationale: This protocol leverages the sensitivity and specificity of tandem mass spectrometry for accurate quantification, making it ideal for low-level detection in complex matrices. [\[12\]](#)
 1. Sample Preparation (Solid-Phase Extraction): [\[10\]](#) * Condition a hydrophilic-lipophilic balanced (HLB) SPE cartridge with 1 mL of methanol followed by 1 mL of water.
 - Dilute 0.5 mL of sample (e.g., plasma) with 0.5 mL of 4% phosphoric acid and add an internal standard.
 - Load the mixture onto the SPE cartridge.
 - Wash the cartridge with 1 mL of 5% methanol in water.
 - Dry the cartridge under vacuum for 2 minutes.
 - Elute the analytes with 1 mL of methanol.
 - Evaporate the eluate to dryness and reconstitute in 100 µL of the initial mobile phase.
- LC-MS/MS Parameters:
 - LC System: Shimadzu LC-20AD or equivalent. [\[12\]](#) * Column: C18 reversed-phase column (e.g., Kinetex C18, 50 x 2.1 mm, 2.6 µm). [\[12\]](#) * Mobile Phase A: 0.1% formic acid in water. [\[12\]](#) * Mobile Phase B: 0.1% formic acid in acetonitrile. [\[12\]](#) * Flow Rate: 0.3 mL/min.
 - Gradient: 10% B to 90% B over 6 minutes, hold for 1.5 min, then re-equilibrate.
 - MS System: Q-TOF or Triple Quadrupole instrument.

- Ionization: Electrospray Ionization (ESI), Positive Mode.
- Ion Source Temp: ~400°C. [12] * Acquisition Mode: Multiple Reaction Monitoring (MRM). Select the $[M+H]^+$ as the precursor ion and monitor for at least two characteristic product ions (e.g., m/z 121 and m/z 58 for N-allyl phenethylamine).
- Data Analysis: Integrate the peak areas for the MRM transitions. Quantify using a calibration curve prepared with certified reference materials.

Conclusion

The mass spectrometric fragmentation of N-allyl phenethylamines is a predictable process governed by fundamental principles of ion chemistry. Under Electron Ionization, fragmentation is dominated by a characteristic β -cleavage, yielding highly stable tropylium and N-allyl immonium ions. Under Electrospray Ionization, tandem MS analysis of the protonated molecule reveals facile cleavages of the bonds adjacent to the nitrogen atom. A comprehensive analytical strategy effectively combines both GC-MS for robust qualitative identification and LC-MS/MS for sensitive and specific quantification. The further application of high-resolution mass spectrometry provides an unparalleled level of confidence by confirming elemental compositions, solidifying structural elucidation, and enabling the detection of novel analogs in an ever-evolving analytical landscape.

References

- Characterization of synthetic phenethylamines using low-resolution and high-resolution mass spectrometry. Digital Repository at the University of Maryland. Available at: [\[Link\]](#)
- Pasin, D., Cawley, A., Bidny, S., & Fu, S. (2017). Characterization of hallucinogenic phenethylamines using high-resolution mass spectrometry for non-targeted screening purposes. *Drug Testing and Analysis*, 9(10), 1620-1629. Available at: [\[Link\]](#)
- Nakashima, D., et al. (2021). Study of Substituted Phenethylamine Fragmentation Induced by Electrospray Ionization Mass Spectrometry and Its Application for Highly Sensitive Analysis of Neurotransmitters in Biological Samples. *Journal of the American Society for Mass Spectrometry*, 32(8), 2144-2152. Available at: [\[Link\]](#)

- Nakashima, D., et al. (2020). In-Source Fragmentation of Phenethylamines by Electrospray Ionization Mass Spectrometry: Toward Highly Sensitive Quantitative Analysis of Monoamine Neurotransmitters. *Analytical Chemistry*, 92(17), 11881-11888. Available at: [\[Link\]](#)
- Anstett, A., Chu, F., & Dea, D. (2018). Characterization of 2C-phenethylamines Using High-Resolution Mass Spectrometry and Kendrick Mass Defect Filters. Office of Justice Programs. Available at: [\[Link\]](#)
- Sekuła, K., Wrzesień-Tokarczyk, W., & Zuba, D. (2019). Analysis of the fragmentation of new-type phenethylamine derivatives from the NBOMe and NBF groups under electrospray ionization conditions using high resolution mass spectrometry. *Problems of Forensic Sciences*, 118, 157-169. Available at: [\[Link\]](#)
- Joye, T., et al. (2022). Developments in high-resolution mass spectrometric analyses of new psychoactive substances. *Drug Testing and Analysis*, 14(5), 793-815. Available at: [\[Link\]](#)
- Nakashima, D., et al. (2021). Fragmentation Study of Substituted Phenethylamines Induced by Electrospray Ionization Mass Spectrometry and Its Application for Highly Sensitive Analysis of Neurotransmitters in Biological Sample - Supporting Information. ACS Publications. Available at: [\[Link\]](#)
- Zuba, D. (2013). Structural elucidation and identification of a new derivative of phenethylamine using quadrupole time-of-flight mass spectrometry. *Rapid Communications in Mass Spectrometry*, 27(15), 1735-1742. Available at: [\[Link\]](#)
- Papaseit, E., et al. (2014). Validated LC–MS-MS Method for Multiresidual Analysis of 13 Illicit Phenethylamines in Amniotic Fluid. *Journal of Analytical Toxicology*, 38(7), 428-434. Available at: [\[Link\]](#)
- Snow, N. H. (2020). Interaction of Dichloromethane Solvent with n-Alkylamines Analyzed by Electron Ionization GC–MS. LCGC International. Available at: [\[Link\]](#)
- Sekuła, K., & Zuba, D. (2020). Analysis of the fragmentation of new-type phenethylamine derivatives from the NBOMe and NBF groups under electrospray ionization conditions using high resolution mass spectrometry. *Problems of Forensic Sciences*, 118, 157-169. Available at: [\[Link\]](#)

- Lin, H. R., et al. (2018). Comparison of the Characteristic Mass Fragmentations of Phenethylamines and Tryptamines by Electron Ionization Gas Chromatography Mass Spectrometry, Electrospray and Matrix-Assisted Laser Desorption Ionization Mass Spectrometry. *Molecules*, 23(7), 1553. Available at: [\[Link\]](#)
- Lin, H. R., et al. (2018). Comparison of the Characteristic Mass Fragmentations of Phenethylamines and Tryptamines by Electron Ionization Gas Chromatography Mass Spectrometry, Electrospray and Matrix-Assisted Laser Desorption Ionization Mass Spectrometry. ResearchGate. Available at: [\[Link\]](#)
- Rana, S., & Liddle, R. (2017). Gas Chromatography Mass Spectrometry (GC-MS) for Identification of Designer Stimulants Including 2C Amines, NBOMe Compounds, and Cathinones. *Current Protocols in Toxicology*, 74, 4.43.1-4.43.20. Available at: [\[Link\]](#)
- Tsai, F. S., et al. (2021). Simultaneous LC-MS/MS screening for multiple phenethylamine-type conventional drugs and new psychoactive substances in urine. *Forensic Science International*, 325, 110884. Available at: [\[Link\]](#)
- Shimadzu Corporation. (2022). Analysis of Phenethylamines Using On-Column TFA Derivatization. Application News No. 01-00823-EN. Available at: [\[Link\]](#)
- University of Colorado Boulder. Fragmentation Mechanisms. Intro to Mass Spectrometry. Available at: [\[Link\]](#)

Need Custom Synthesis?

BenchChem offers custom synthesis for rare earth carbides and specific isotopic labeling.

Email: info@benchchem.com or [Request Quote Online](#).

Sources

1. d.lib.msu.edu [d.lib.msu.edu]
2. [pmc.ncbi.nlm.nih.gov](https://pubmed.ncbi.nlm.nih.gov) [[pmc.ncbi.nlm.nih.gov](https://pubmed.ncbi.nlm.nih.gov)]
3. Characterization of 2C-phenethylamines Using High-Resolution Mass Spectrometry and Kendrick Mass Defect Filters | Office of Justice Programs [ojp.gov]

- [4. mdpi.com \[mdpi.com\]](#)
- [5. researchgate.net \[researchgate.net\]](#)
- [6. orgchemboulder.com \[orgchemboulder.com\]](#)
- [7. Characterization of hallucinogenic phenethylamines using high-resolution mass spectrometry for non-targeted screening purposes - PubMed \[pubmed.ncbi.nlm.nih.gov\]](#)
- [8. shimadzu.com \[shimadzu.com\]](#)
- [9. scispace.com \[scispace.com\]](#)
- [10. benchchem.com \[benchchem.com\]](#)
- [11. caymanchem.com \[caymanchem.com\]](#)
- [12. Validated LC–MS-MS Method for Multiresidual Analysis of 13 Illicit Phenethylamines in Amniotic Fluid - PMC \[pmc.ncbi.nlm.nih.gov\]](#)
- To cite this document: BenchChem. [Introduction: The Analytical Challenge of N-Allyl Phenethylamines]. BenchChem, [2026]. [Online PDF]. Available at: [\[https://www.benchchem.com/product/b13345981/docs#introduction-the-analytical-challenge-of-n-allyl-phenethylamines\]](https://www.benchchem.com/product/b13345981/docs#introduction-the-analytical-challenge-of-n-allyl-phenethylamines)

Disclaimer & Data Validity:

The information provided in this document is for Research Use Only (RUO) and is strictly not intended for diagnostic or therapeutic procedures. While BenchChem strives to provide accurate protocols, we make no warranties, express or implied, regarding the fitness of this product for every specific experimental setup.

Technical Support: The protocols provided are for reference purposes. Unsure if this reagent suits your experiment?

Need Industrial/Bulk Grade? [Request Custom Synthesis Quote](#)

BenchChem

Our mission is to be the trusted global source of essential and advanced chemicals, empowering scientists and researchers to drive progress in science and industry.

Contact

Address: 3281 E Guasti Rd

Ontario, CA 91761, United States

Phone: (601) 213-4426

Email: info@benchchem.com

[Contact our Ph.D. Support Team for a compatibility check](#)