

Technical Support Center: Pyrazole Derivative Experiments

Author: BenchChem Technical Support Team. **Date:** May 2026

Compound of Interest

Compound Name: *5-Methyl-1-(2-methylbutyl)-1H-pyrazol-3-amine*

Cat. No.: *B13339115*

[Get Quote](#)

Topic: Troubleshooting & Optimization Guide for Pyrazole Synthesis and Functionalization

Introduction

Welcome to the Technical Support Center. Pyrazoles are privileged scaffolds in medicinal chemistry, forming the core of blockbuster drugs like Celecoxib and Sildenafil. However, their amphoteric nature and annular tautomerism present unique challenges in synthesis, purification, and characterization.

This guide moves beyond basic textbook definitions to address the specific "why" and "how" of experimental failure, providing self-validating protocols to ensure reproducibility.

Module 1: Synthesis & Regioselectivity

Q1: My Knorr synthesis (1,3-diketone + hydrazine) yields a mixture of regioisomers. How do I control the selectivity?

A: The Knorr reaction's regioselectivity is governed by the competition between steric bulk and electronic hardness.[1]

- The Mechanism: The reaction proceeds via an initial nucleophilic attack of the hydrazine nitrogen on a carbonyl carbon.
 - Substituted Hydrazines: The group is the harder, more nucleophilic center compared to the group.
 - 1,3-Diketones: The attack preferentially occurs at the more electrophilic (electronically controlled) or less hindered (sterically controlled) carbonyl.

Troubleshooting Protocol:

- Assess Your Substrate:
 - If your diketone has a bulky group (e.g., -Butyl) and a small group (e.g., Methyl), sterics will dominate. The of the hydrazine attacks the less hindered carbonyl (Methyl side), placing the bulky group at the 3-position of the final pyrazole.
 - If groups are sterically similar (e.g., Methyl vs. Phenyl), electronic control is weak in standard solvents like Ethanol.
- Switch Solvents (The "Magic" Fix): Recent data confirms that fluorinated alcohols can invert or drastically enhance regioselectivity.
 - Ethanol (Standard): Often gives 1:1 to 3:1 mixtures.
 - HFIP (Hexafluoroisopropanol) or TFE (Trifluoroethanol): These solvents activate the carbonyls via strong hydrogen bonding. They often favor the formation of 5-substituted pyrazoles (contrary to steric prediction) by stabilizing specific intermediates.

Data: Solvent Effects on Regioselectivity | Solvent | Dielectric Constant | H-Bond Donor (

) | Typical Regio Ratio (5-aryl : 3-aryl) | | :--- | :--- | :--- | :--- | | Ethanol | 24.5 | 0.83 | ~ 60 : 40 | |
Toluene | 2.4 | 0.00 | ~ 55 : 45 | | TFE | 26.7 | 1.51 | > 95 : 5 | | HFIP | 16.7 | 1.96 | > 98 : 2 |

“

Reference: Fustero et al. demonstrated that fluorinated solvents stabilize the intermediate hydrazone in a way that dictates cyclization direction [1].

Visualization: Regioselectivity Decision Tree

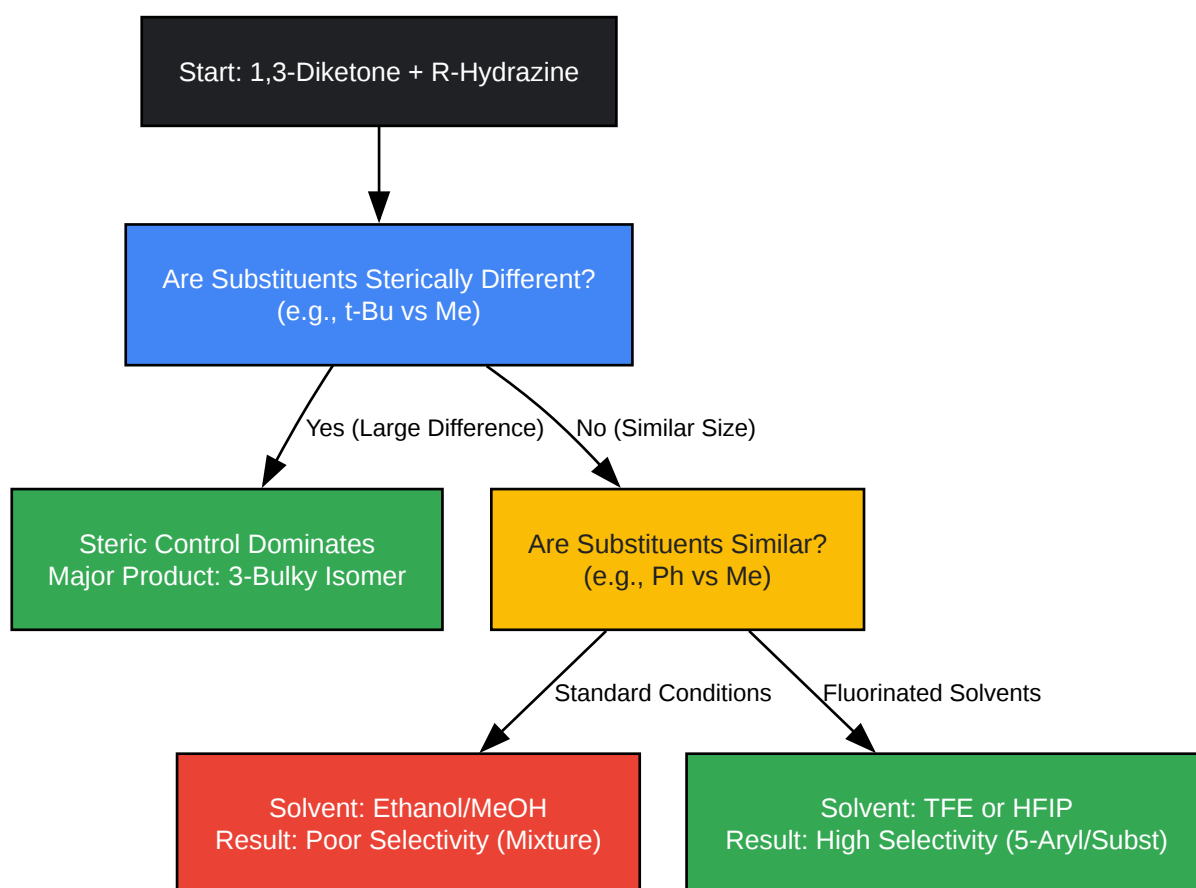

[Click to download full resolution via product page](#)

Caption: Logic flow for predicting and controlling regioisomers in Knorr Pyrazole Synthesis.

Module 2: Functionalization (N-Alkylation)

Q2: I am alkylating a pyrazole ring, but I cannot control N1 vs. N2 selectivity. Why?

A: This is a classic "ambident nucleophile" problem. The pyrazole anion can react at either nitrogen.

- Thermodynamic Control: Favors the isomer where the substituent is further from adjacent steric bulk (usually N1-alkylation for 3-substituted pyrazoles).
- Kinetic Control: Can be influenced by the "coordination" of the metal cation.

Optimization Strategy:

- Base Selection:
 - / THF: "Naked" anion often reacts at the most electron-rich nitrogen, but coordination to can direct alkylation to N2 (the more hindered side) via a "chelation control" mechanism if a donor group is present at C3.
 - / Acetone or DMF: Generally favors the thermodynamic product (less hindered N1-alkylation).
 - : The large Cesium cation dissociates completely, maximizing the steric repulsion effect, pushing selectivity toward the unhindered N1 position.
- Protocol: Regioselective N-Alkylation (Thermodynamic)
 - Step 1: Dissolve pyrazole (1.0 equiv) in DMF (0.2 M).
 - Step 2: Add (1.5 equiv). Stir for 30 min at RT.^[1]
 - Step 3: Add Alkyl Halide (1.1 equiv) dropwise.
 - Step 4: Monitor by TLC.^{[1][2][3]} If N2-alkylation is observed, lower temperature to 0°C.

Module 3: Purification & Isolation

Q3: My product is an oil and won't crystallize. Silica columns cause streaking. How do I purify it?

A: Pyrazoles are "sticky" on silica due to the basic pyridine-like nitrogen interacting with acidic silanols.

- Chromatography Fix: Pre-treat your silica column with 1% Triethylamine () in Hexanes before loading. This neutralizes the acidic sites.
- Extraction Fix: Use the Acid-Base Salt Formation method.^[4] Pyrazoles are weak bases (of conjugate acid ~ 2.5). You can exploit this for purification without a column.^[4]

Standard Operating Procedure: Acid-Base Purification

Step	Action	Mechanism
1	Dissolve crude oil in Diethyl Ether or MTBE.	Solubilizes neutral impurities and the pyrazole.
2	Add 2M HCl in Ether (anhydrous) or extract with 1M aq. HCl.	Protonates the N2 nitrogen, forming the pyrazolium salt.
3	Precipitation: If using anhydrous acid, the salt precipitates. Filter it. Extraction: If using aq. HCl, separate the aqueous layer (contains product).[5]	Separates product from non-basic organic impurities.
4	Wash the salt/aqueous layer with fresh Ether.	Removes trapped neutral organic byproducts.
5	Basify aqueous layer (pH > 9) with or .	Regenerates the free base pyrazole.
6	Extract into DCM, dry over , and evaporate.	Recovers pure pyrazole.

“

Reference: This method relies on the amphoteric nature of pyrazoles described in *The Journal of Organic Chemistry* [2].

Module 4: Characterization (NMR)

Q4: My NMR spectrum shows broad "humps" instead of sharp signals, or carbon signals are missing. Is my compound impure?

A: Likely not. This is Annular Tautomerism. In solution, N-unsubstituted pyrazoles undergo rapid proton transfer between N1 and N2.

- The Symptom: If the exchange rate is intermediate on the NMR timescale, the signals for C3 and C5 (and attached protons) broaden or coalesce into an average.
- Verification: The C3 and C5 signals will often disappear in NMR due to extreme broadening.

Diagnostic Workflow:

- Change Solvent: Switch from

to DMSO-

. DMSO forms strong H-bonds with the NH, slowing the exchange rate and often sharpening the signals.
- Variable Temperature (VT) NMR:
 - Cooling (-40°C): Slows exchange; you may see two distinct sets of peaks (one for each tautomer).
 - Heating (+60°C): Accelerates exchange; peaks coalesce into sharp, averaged signals.
- Chemical Shift Lock: Add a drop of TFA (Trifluoroacetic acid) or Hydrazine hydrate. This forces the equilibrium to a single protonated or deprotonated species, instantly sharpening the spectrum.

Visualization: Troubleshooting Workflow

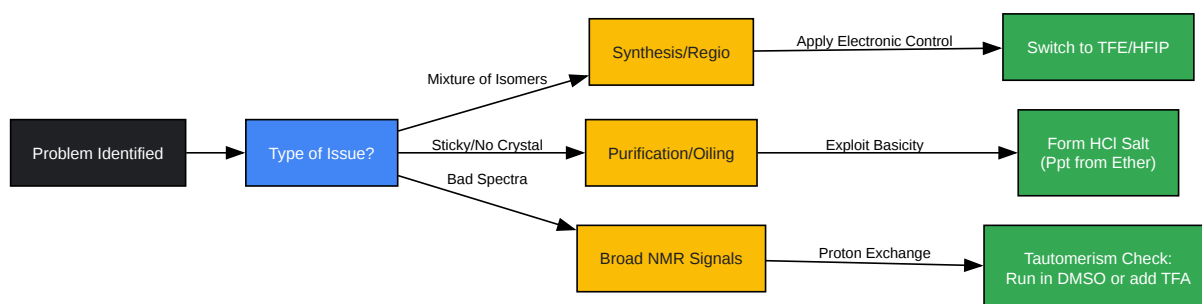

[Click to download full resolution via product page](#)

Caption: Rapid diagnostic path for common pyrazole experimental failures.

References

- Improved Regioselectivity in Pyrazole Formation through the Use of Fluorinated Alcohols. The Journal of Organic Chemistry. [\[Link\]](#)
- Highly Selective N-Alkylation of Pyrazoles: Crystal Structure Evidence for Attractive Interactions. The Journal of Organic Chemistry. [\[Link\]](#)
- Acid–base extraction. Wikipedia. [\[Link\]](#)
- Revisiting the Structure and Chemistry of 3(5)-Substituted Pyrazoles. Molecules (PMC). [\[Link\]](#)

Need Custom Synthesis?

BenchChem offers custom synthesis for rare earth carbides and specific isotopic labeling.

Email: info@benchchem.com or [Request Quote Online](#).

Sources

- [1. pdf.benchchem.com](https://pdf.benchchem.com) [\[pdf.benchchem.com\]](#)

- [2. researchgate.net \[researchgate.net\]](https://www.researchgate.net)
- [3. chemhelpasap.com \[chemhelpasap.com\]](https://www.chemhelpasap.com)
- [4. Acid–base extraction - Wikipedia \[en.wikipedia.org\]](https://en.wikipedia.org)
- [5. people.chem.umass.edu \[people.chem.umass.edu\]](https://people.chem.umass.edu)
- To cite this document: BenchChem. [Technical Support Center: Pyrazole Derivative Experiments]. BenchChem, [2026]. [Online PDF]. Available at: [\[https://www.benchchem.com/product/b13339115/docs#technical-support-center-pyrazole-derivative-experiments\]](https://www.benchchem.com/product/b13339115/docs#technical-support-center-pyrazole-derivative-experiments)

Disclaimer & Data Validity:

The information provided in this document is for Research Use Only (RUO) and is strictly not intended for diagnostic or therapeutic procedures. While BenchChem strives to provide accurate protocols, we make no warranties, express or implied, regarding the fitness of this product for every specific experimental setup.

Technical Support: The protocols provided are for reference purposes. Unsure if this reagent suits your experiment?

Need Industrial/Bulk Grade? [Request Custom Synthesis Quote](#)

BenchChem

Our mission is to be the trusted global source of essential and advanced chemicals, empowering scientists and researchers to drive progress in science and industry.

Contact

Address: 3281 E Guasti Rd
Ontario, CA 91761, United States
Phone: (601) 213-4426
Email: info@benchchem.com

[Contact our Ph.D. Support Team for a compatibility check](#)

