

# The Acid-Labile Revolution: A Technical Guide to Boc-Protected Amino Acids

**Author:** BenchChem Technical Support Team. **Date:** May 2026

## Compound of Interest

**Compound Name:** 2-(2-Tert-butoxycarbonylamino-ethylamino)-nicotinic acid

**CAS No.:** 904815-14-1

**Cat. No.:** B1333189

[Get Quote](#)

## Executive Summary

The introduction of the tert-butyloxycarbonyl (Boc) protecting group marked a pivotal shift in peptide chemistry, transitioning the field from laborious solution-phase synthesis to the automated era of Solid-Phase Peptide Synthesis (SPPS). This guide analyzes the historical discovery of the Boc group, the chemical mechanisms that define its utility, and the experimental protocols that remain relevant in modern drug development.

## The Orthogonality Problem: Contextualizing the Discovery

Before 1957, peptide synthesis relied heavily on the benzyloxycarbonyl (Cbz or Z) group, introduced by Bergmann and Zervas in 1932. While revolutionary, the Cbz group required either strong acids (HBr/AcOH) or catalytic hydrogenation for removal.

**The Limitation:** Complex peptide synthesis requires orthogonality—the ability to remove one protecting group without affecting others. The Cbz group lacked sufficient differentiation from

the benzyl ester side-chain protection used at the time. Chemists needed a group that was stable to base and hydrogenation but labile to mild acid, creating a "graded acid lability" strategy.

## The 1957 Breakthrough

In 1957, two independent groups solved this problem almost simultaneously, introducing the Boc group:

- Louis A. Carpino (University of Massachusetts) described the synthesis of tert-butyl azidoformate and its reaction with amines.
- F.C. McKay and N.F. Albertson similarly reported the use of tert-butyl esters for amine protection.

This discovery introduced the Boc/Bzl strategy:

- Temporary Protection (N-terminus): Boc (Removed by mild acid: TFA).
- Permanent Protection (Side-chains): Benzyl (Bzl) derivatives (Removed by strong acid: HF or TFMSA).

## Reagent Evolution: From Explosives to Anhydrides

The utility of the Boc group was initially hampered by the reagents used to introduce it.

### Generation 1: tert-Butyl Azidoformate (1957–1970s)

Carpino's original reagent was effective but hazardous. It was thermally unstable, toxic, and shock-sensitive. Despite this, it drove the early years of Boc chemistry.

### Generation 2: "Boc-ON" and Fluorinated Reagents

To mitigate safety risks, reagents like 2-(tert-butoxycarbonyloxyimino)-2-phenylacetonitrile (Boc-ON) were developed. These were safer but produced oxime byproducts that were difficult to remove.

## Generation 3: Di-tert-butyl Dicarbonate (Boc<sub>2</sub>O) (1972–Present)

The definitive solution arrived when D.S. Tarbell and colleagues synthesized Di-tert-butyl dicarbonate (Boc anhydride or Boc<sub>2</sub>O).

- Advantages: Crystalline solid, stable, reacts rapidly with amines, and produces only inert byproducts (tert-butanol and CO<sub>2</sub>).
- Impact: This reagent democratized Boc chemistry, making it accessible for large-scale pharmaceutical manufacturing.

## Mechanistic Deep Dive: Acidolysis and Scavenging

The Boc group's lability stems from the stability of the tert-butyl carbocation.

### The Deprotection Mechanism

The cleavage of the Boc group by Trifluoroacetic Acid (TFA) follows an E1/S<sub>N</sub>1 pathway:

- Protonation: The carbonyl oxygen of the urethane linkage is protonated.
- Fragmentation: The bond between the tert-butyl group and the oxygen cleaves, generating a tert-butyl cation and a carbamic acid.
- Decarboxylation: The carbamic acid is unstable and spontaneously loses CO<sub>2</sub> to yield the free amine.
- Cation Fate: The generated tert-butyl cation is highly reactive. Without intervention, it will re-attach to nucleophilic side chains (e.g., Trp, Tyr, Met), causing permanent alkylation.

Critical Protocol Note: This mechanism dictates the mandatory use of scavengers (e.g., water, triisopropylsilane, thioanisole) in the deprotection cocktail to quench the tert-butyl cation.

## Visualization: Boc Deprotection Pathway

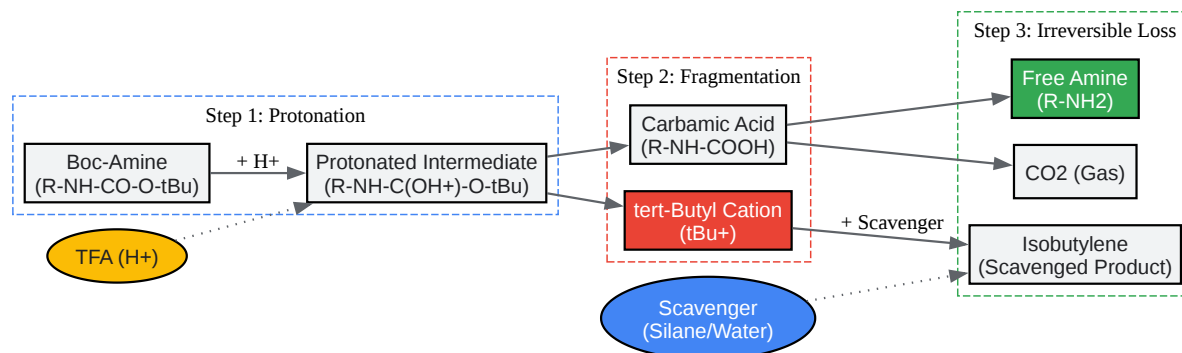

[Click to download full resolution via product page](#)

Caption: The acid-catalyzed cleavage of the Boc group, highlighting the critical role of scavengers in neutralizing the reactive tert-butyl cation.

## Experimental Protocols

### Protocol A: Synthesis of Boc-Amino Acids (Standard $Boc_2O$ Method)

Use Case: Protecting a raw amino acid for subsequent use in synthesis.

Materials:

- Amino Acid (10 mmol)
- Di-tert-butyl dicarbonate ( $Boc_2O$ ) (11 mmol)
- Sodium Hydroxide (1N NaOH) or Triethylamine (TEA)
- Dioxane/Water (1:1 v/v)

Methodology:

- Dissolution: Dissolve the amino acid in a mixture of water and dioxane (or THF).
- pH Adjustment (Critical): Adjust pH to ~9-10 using NaOH or TEA.
  - Why? The amine must be unprotonated (nucleophilic) to react with  $\text{Boc}_2\text{O}$ , but too high pH (>11) promotes hydrolysis of the  $\text{Boc}_2\text{O}$  reagent itself.
- Addition: Add  $\text{Boc}_2\text{O}$  (1.1 equivalents) slowly at  $0^\circ\text{C}$ , then allow to warm to room temperature.
- Monitoring: Stir for 4–12 hours. Monitor by TLC (disappearance of ninhydrin-active spot).
- Workup:
  - Evaporate organic solvent.
  - Acidify the aqueous layer carefully with  $\text{KHSO}_4$  or dilute HCl to pH 2–3.
  - Why? This protonates the carboxylic acid, making the Boc-amino acid soluble in organic extraction solvents (Ethyl Acetate).
- Extraction: Extract with Ethyl Acetate, wash with brine, dry over  $\text{MgSO}_4$ , and concentrate.

## Protocol B: Boc Deprotection in SPPS

Use Case: Removing the N-terminal protection during chain assembly.

Materials:

- Trifluoroacetic Acid (TFA)
- Dichloromethane (DCM)
- Scavengers (if sensitive side chains are present)

Methodology:

- Pre-wash: Wash resin with DCM (3x).

- Cleavage: Treat resin with 50% TFA in DCM (v/v) for 1–2 minutes (Flow wash).
- Incubation: Treat again with 50% TFA/DCM for 20–30 minutes.
  - Why? The first short wash removes bulk impurities; the second ensures complete removal of the Boc group.
- Neutralization (Crucial for Coupling):
  - Wash with DCM.
  - Wash with 5-10% Diisopropylethylamine (DIPEA) in DCM.
  - Why? TFA leaves the N-terminal amine as a salt ( $-\text{NH}_3^+\text{TFA}^-$ ). It must be neutralized to the free amine ( $-\text{NH}_2$ ) to react with the next activated amino acid.

## Comparative Analysis: Boc vs. Fmoc

While Fmoc is currently dominant due to the avoidance of HF, Boc remains vital for specific applications, particularly in synthesizing difficult sequences prone to aggregation (pseudoproline effects) and thioester synthesis.

Feature	Boc Strategy	Fmoc Strategy
Deprotection Reagent	50% TFA (Acid)	20% Piperidine (Base)
Cleavage from Resin	HF or TFMSA (Strong Acid)	95% TFA (Mild Acid)
Orthogonality	Acid/Acid (Graded lability)	Base/Acid (True Orthogonality)
Solubility	High (TFA breaks aggregates)	Variable (Aggregation can occur)
Cost	Lower reagent cost	Higher reagent cost
Safety	High (HF is extremely hazardous)	Moderate (Piperidine is a precursor)

## The Merrifield SPPS Cycle (Boc/Bzl)

The integration of Boc chemistry into R.B. Merrifield's solid-phase system earned him the Nobel Prize. The cycle relies on the differential acid stability of Boc (temporary) vs. Benzyl (permanent).

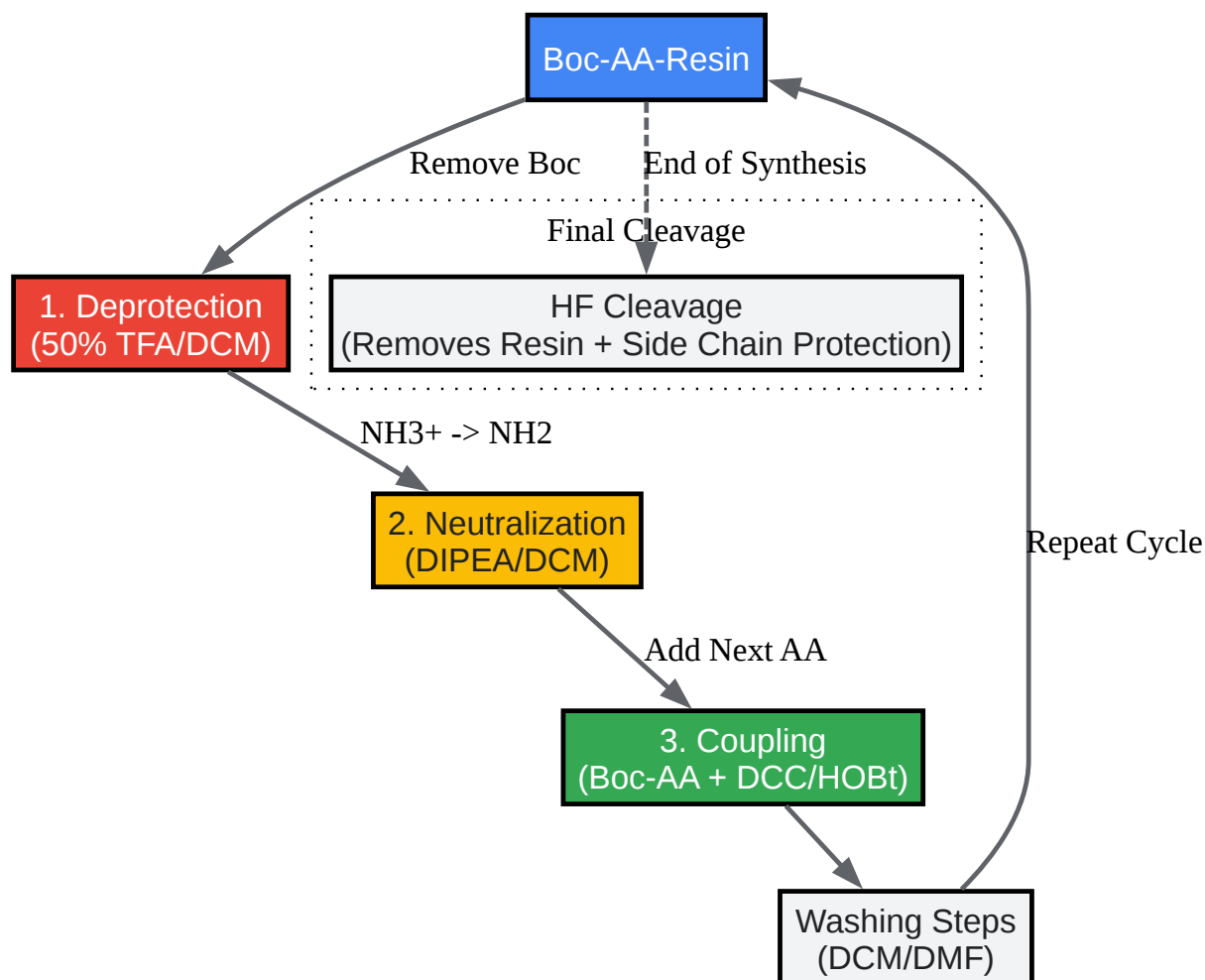

[Click to download full resolution via product page](#)

Caption: The standard Boc/Bzl Solid-Phase Peptide Synthesis cycle. Note the requirement for a neutralization step distinct from the deprotection step.

## References

- Carpino, L. A. (1957). Oxidative Reactions of Hydrazines. IV. Elimination of Nitrogen from 1,1-Disubstituted-2-arenesulfonylhydrazides. *Journal of the American Chemical Society*,

79(16), 4427–4431. [[Link](#)](Note: This is the seminal paper describing the tert-butyl azidoformate reagent).

- McKay, F. C., & Albertson, N. F. (1957). New Amine-masking Groups for Peptide Synthesis. *Journal of the American Chemical Society*, 79(17), 4686–4690. [[Link](#)]
- Merrifield, R. B. (1963). Solid Phase Peptide Synthesis. I. The Synthesis of a Tetrapeptide. *Journal of the American Chemical Society*, 85(14), 2149–2154. [[Link](#)]
- Tarbell, D. S., et al. (1972). New Method for Preparation of Di-tert-butyl Carbonate and Its Use for Introduction of the tert-Butyloxycarbonyl Group. *Proceedings of the National Academy of Sciences*, 69(3), 730–732. [[Link](#)]
- Lundt, B. F., et al. (1978). Selective Removal of the N-alpha-Boc Group in Solid Phase Peptide Synthesis. *International Journal of Peptide and Protein Research*, 12(5), 258–268. [[Link](#)]
- To cite this document: BenchChem. [The Acid-Labile Revolution: A Technical Guide to Boc-Protected Amino Acids]. BenchChem, [2026]. [Online PDF]. Available at: [<https://www.benchchem.com/product/b1333189/docs#the-acid-labile-revolution-a-technical-guide-to-boc-protected-amino-acids>]

---

### Disclaimer & Data Validity:

The information provided in this document is for Research Use Only (RUO) and is strictly not intended for diagnostic or therapeutic procedures. While BenchChem strives to provide accurate protocols, we make no warranties, express or implied, regarding the fitness of this product for every specific experimental setup.

**Technical Support:** The protocols provided are for reference purposes. Unsure if this reagent suits your experiment?

**Need Industrial/Bulk Grade?** [Request Custom Synthesis Quote](#)



# BenchChem

Our mission is to be the trusted global source of essential and advanced chemicals, empowering scientists and researchers to drive progress in science and industry.

## Contact

Address: 3281 E Guasti Rd

Ontario, CA 91761, United States

Phone: (601) 213-4426

Email: [info@benchchem.com](mailto:info@benchchem.com)

[Contact our Ph.D. Support Team for a compatibility check](#)