

Navigating the Selectivity Landscape of 4-(Trifluoromethyl)piperidine Derivatives: A Comparative Guide

Author: BenchChem Technical Support Team. **Date:** December 2025

Compound of Interest

Compound Name: 4-(Trifluoromethyl)piperidine

Cat. No.: B1330362

[Get Quote](#)

For researchers, scientists, and drug development professionals, understanding the cross-reactivity profile of drug candidates is paramount to mitigating potential off-target effects and ensuring clinical success. This guide provides an objective comparison of the cross-reactivity of various **4-(Trifluoromethyl)piperidine** derivatives, a scaffold increasingly utilized in medicinal chemistry for its ability to enhance metabolic stability and cell permeability. The following sections present available experimental data, detail the methodologies for key experiments, and visualize relevant biological pathways and experimental workflows.

The **4-(trifluoromethyl)piperidine** moiety is a key structural feature in a number of potent and selective therapeutic candidates. The trifluoromethyl group can significantly influence a compound's lipophilicity, metabolic stability, and binding affinity, thereby improving its pharmacokinetic profile.^{[1][2]} However, the piperidine ring, a common scaffold in many centrally active drugs, can also contribute to off-target binding at various receptors, ion channels, and enzymes.^[3] Therefore, a thorough assessment of the cross-reactivity of these derivatives is essential during the drug discovery and development process.

Comparative Analysis of Cross-Reactivity Data

While a comprehensive public dataset profiling a single **4-(trifluoromethyl)piperidine** derivative against a broad panel of off-targets is not readily available, data from several studies on distinct derivatives targeting different primary receptors offer valuable insights into their

selectivity. The following tables summarize the available cross-reactivity data for representative compounds.

Case Study 1: CCR5 Antagonists for HIV-1 Inhibition

A series of piperazine-based CCR5 antagonists containing the 4-(trifluoromethyl)phenyl moiety have been developed as potent inhibitors of HIV-1 entry. Lead optimization efforts focused on improving selectivity against muscarinic receptors (M1 and M2).

Compound	Primary Target	Off-Target	Binding Affinity (Ki, nM)	Selectivity (Off-Target Ki / Primary Target Ki)
Sch-350634	CCR5	M1	>1000	>100
M2	>1000	>100		
Sch-417690/Sch-D	CCR5	M1	>1000	>100
M2	>1000	>100		

Data sourced from publications on piperazine-based CCR5 antagonists.[\[4\]](#)[\[5\]](#)

These data indicate that targeted medicinal chemistry efforts were successful in achieving high selectivity for the intended CCR5 target over the muscarinic receptors, which are common off-targets for piperidine-containing compounds.

Case Study 2: NK1 Receptor Antagonists for Emesis

Tetrahydropyridine derivatives incorporating a 3,5-bis(trifluoromethyl)benzyl group have been investigated as potent neurokinin-1 (NK1) receptor antagonists for the treatment of chemotherapy-induced nausea and vomiting.

Compound	Primary Target	In Vitro Potency (IC50, nM)	In Vivo Efficacy (ED50, mg/kg, p.o.)
Compound 3a	NK1 Receptor	-	0.27
Compound 3b	NK1 Receptor	-	0.20
Compound 3f	NK1 Receptor	-	0.24

Data presented as reported in the study, which focused on on-target potency and in vivo efficacy rather than a broad off-target screen.[6]

While a comprehensive cross-reactivity panel was not reported for these compounds, their high in vivo potency at low doses suggests a favorable selectivity profile.

Case Study 3: Opioid Receptor Agonists for Analgesia

A computationally designed molecule, PZM21, which features a substituted piperidine, was identified as a potent μ -opioid receptor (μ OR) agonist with reduced side effects. Its selectivity was assessed against a broad panel of G-protein coupled receptors (GPCRs) and other targets.

Compound	Primary Target	Off-Target	Activity
PZM21	μ -Opioid Receptor	316 other GPCRs	No potent activity at 10 μ M
hERG Ion Channel	IC50 between 2 and 4 μ M		
Dopamine Transporter	IC50 = 7.8 μ M		
Norepinephrine Transporter	IC50 = 34 μ M		
Serotonin Transporter	IC50 > 10 μ M		

PZM21 is a selective G-protein biased μ OR agonist.[7]

The data for PZM21 demonstrates high selectivity for the μ -opioid receptor over a wide range of other GPCRs, with significantly weaker activity at the hERG channel and monoamine transporters.

Experimental Protocols

To ensure the reliability and reproducibility of cross-reactivity data, standardized experimental protocols are crucial. Below are detailed methodologies for common assays used in selectivity profiling.

Radioligand Binding Assay (Generic Protocol)

This assay measures the ability of a test compound to displace a radiolabeled ligand from its receptor.

Materials:

- Cell membranes or purified receptors expressing the target of interest.
- Radiolabeled ligand (e.g., [3 H]-spiperone for dopamine D2 receptors).
- Test compound (**4-(Trifluoromethyl)piperidine** derivative).
- Assay buffer (e.g., 50 mM Tris-HCl, pH 7.4, 120 mM NaCl, 5 mM KCl, 2 mM CaCl₂, 1 mM MgCl₂).
- Scintillation fluid.
- Glass fiber filters.
- Scintillation counter.

Procedure:

- Prepare serial dilutions of the test compound in the assay buffer.
- In a microplate, combine the cell membranes, radiolabeled ligand at a concentration close to its K_d, and the test compound or vehicle.

- Incubate the mixture at room temperature for a specified time (e.g., 60-120 minutes) to reach equilibrium.
- Rapidly filter the reaction mixture through glass fiber filters using a cell harvester to separate bound from free radioligand.
- Wash the filters with ice-cold assay buffer to remove non-specifically bound radioligand.
- Place the filters in scintillation vials, add scintillation fluid, and quantify the radioactivity using a scintillation counter.
- Determine the concentration of the test compound that inhibits 50% of the specific binding of the radioligand (IC₅₀).
- Calculate the inhibitory constant (K_i) using the Cheng-Prusoff equation: $K_i = IC_{50} / (1 + [L]/K_d)$, where [L] is the concentration of the radiolabeled ligand and K_d is its dissociation constant.

Functional Cellular Assays (e.g., Calcium Mobilization Assay)

This type of assay measures the functional response of a cell upon receptor activation or inhibition by the test compound.

Materials:

- Cells stably expressing the target receptor (e.g., CHO-K1 cells expressing the human CCR5 receptor).
- Fluorescent calcium indicator dye (e.g., Fluo-4 AM).
- Assay buffer (e.g., Hanks' Balanced Salt Solution with 20 mM HEPES).
- Agonist for the target receptor.
- Test compound.
- Fluorescence plate reader.

Procedure:

- Plate the cells in a multi-well plate and allow them to adhere overnight.
- Load the cells with the calcium indicator dye according to the manufacturer's instructions.
- Wash the cells with assay buffer to remove excess dye.
- Add the test compound at various concentrations and incubate for a specified period.
- Add the agonist to stimulate the receptor and immediately measure the change in fluorescence intensity using a plate reader.
- The inhibitory effect of the test compound is determined by the reduction in the agonist-induced calcium signal.
- Calculate the IC₅₀ value, which is the concentration of the test compound that causes a 50% inhibition of the agonist response.

Visualizing Experimental Workflows and Biological Pathways

To further clarify the processes involved in cross-reactivity studies, the following diagrams, generated using Graphviz, illustrate a typical experimental workflow and a simplified signaling pathway.



[Click to download full resolution via product page](#)

Caption: A typical workflow for in vitro cross-reactivity screening.

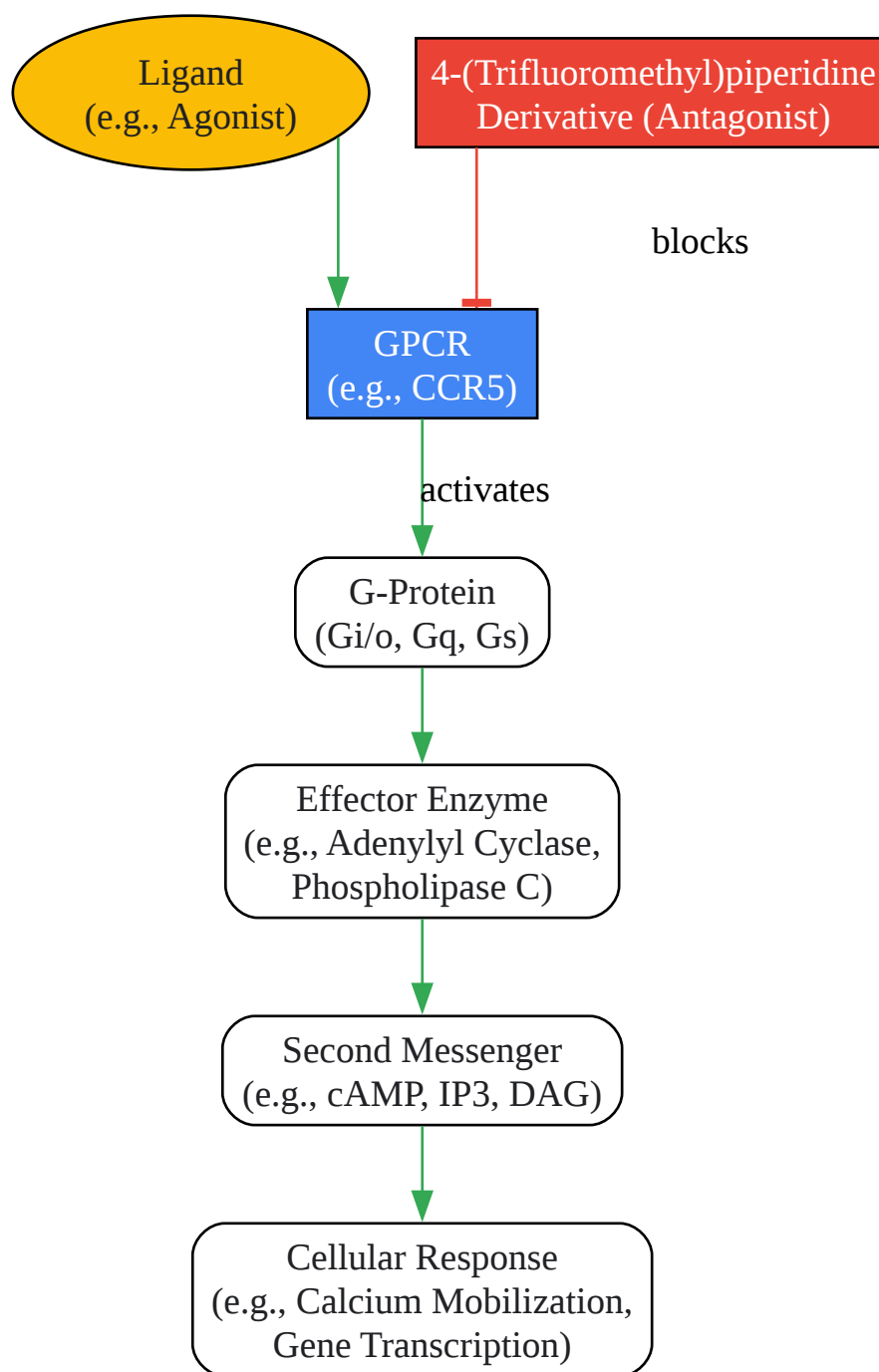

[Click to download full resolution via product page](#)

Caption: Simplified G-protein coupled receptor (GPCR) signaling pathway.

Conclusion

The incorporation of a **4-(trifluoromethyl)piperidine** scaffold in drug design offers significant advantages in optimizing the pharmacokinetic properties of therapeutic candidates. However, a

thorough evaluation of their cross-reactivity is crucial to ensure safety and efficacy. The available data, though not exhaustive for any single compound, suggests that with careful molecular design, high selectivity for the intended target can be achieved. The experimental protocols and workflows outlined in this guide provide a framework for conducting and interpreting cross-reactivity studies, ultimately aiding in the development of safer and more effective medicines. Researchers are encouraged to perform comprehensive selectivity profiling using standardized panels, such as the Eurofins SafetyScreen, to gain a complete understanding of their compounds' off-target interaction profiles.^{[8][9][10][11]}

Need Custom Synthesis?

BenchChem offers custom synthesis for rare earth carbides and specific isotopic labeling.

Email: info@benchchem.com or [Request Quote Online](#).

References

- 1. chemimpex.com [chemimpex.com]
- 2. Chemistry and Pharmacology of Fluorinated Drugs Approved by the FDA (2016–2022) - PMC [pmc.ncbi.nlm.nih.gov]
- 3. Anticancer Applications and Pharmacological Properties of Piperidine and Piperine: A Comprehensive Review on Molecular Mechanisms and Therapeutic Perspectives - PMC [pmc.ncbi.nlm.nih.gov]
- 4. Piperazine-based CCR5 antagonists as HIV-1 inhibitors. II. Discovery of 1-[(2,4-dimethyl-3-pyridinyl)carbonyl]-4-methyl-4-[3(S)-methyl-4-[1(S)-[4-(trifluoromethyl)phenyl]ethyl]-1-piperazinyl]-piperidine N1-oxide (Sch-350634), an orally bioavailable, potent CCR5 antagonist - PubMed [pubmed.ncbi.nlm.nih.gov]
- 5. Piperazine-based CCR5 antagonists as HIV-1 inhibitors. IV. Discovery of 1-[(4,6-dimethyl-5-pyrimidinyl)carbonyl]-4-[4-[2-methoxy-1(R)-4-(trifluoromethyl)phenyl]ethyl-3(S)-methyl-1-piperazinyl]-4-methylpiperidine (Sch-417690/Sch-D), a potent, highly selective, and orally bioavailable CCR5 antagonist - PubMed [pubmed.ncbi.nlm.nih.gov]
- 6. Potent NK1 receptor antagonists: synthesis and antagonistic activity of various heterocycles with an N-[3,5-bis(trifluoromethyl)benzyl]-N-methylcarbamoyl substituent - PubMed [pubmed.ncbi.nlm.nih.gov]
- 7. Structure-based discovery of opioid analgesics with reduced side effects - PMC [pmc.ncbi.nlm.nih.gov]

- 8. Pardon Our Interruption [opnme.com]
- 9. apac.eurofindiscovery.com [apac.eurofindiscovery.com]
- 10. apac.eurofindiscovery.com [apac.eurofindiscovery.com]
- 11. apac.eurofindiscovery.com [apac.eurofindiscovery.com]
- To cite this document: BenchChem. [Navigating the Selectivity Landscape of 4-(Trifluoromethyl)piperidine Derivatives: A Comparative Guide]. BenchChem, [2025]. [Online PDF]. Available at: [https://www.benchchem.com/product/b1330362#cross-reactivity-studies-of-4-trifluoromethyl-piperidine-derivatives]

Disclaimer & Data Validity:

The information provided in this document is for Research Use Only (RUO) and is strictly not intended for diagnostic or therapeutic procedures. While BenchChem strives to provide accurate protocols, we make no warranties, express or implied, regarding the fitness of this product for every specific experimental setup.

Technical Support: The protocols provided are for reference purposes. Unsure if this reagent suits your experiment? [[Contact our Ph.D. Support Team for a compatibility check](#)]

Need Industrial/Bulk Grade? [Request Custom Synthesis Quote](#)

BenchChem

Our mission is to be the trusted global source of essential and advanced chemicals, empowering scientists and researchers to drive progress in science and industry.

Contact

Address: 3281 E Guasti Rd
Ontario, CA 91761, United States
Phone: (601) 213-4426
Email: info@benchchem.com