

# Foreword: The Imperative of Chirality in Modern Drug Discovery

**Author:** BenchChem Technical Support Team. **Date:** May 2026

## Compound of Interest

Compound Name: 5-Cyano-5-methyl-2-pyrrolidone

CAS No.: 86240-21-3

Cat. No.: B1330294

[Get Quote](#)

In the landscape of modern drug development, the three-dimensional architecture of a molecule is not a trivial detail but a fundamental determinant of its biological function. Chirality, the property of 'handedness,' often dictates the difference between a potent therapeutic agent and an inactive or even toxic compound. The pyrrolidine ring is a ubiquitous and privileged scaffold in medicinal chemistry, forming the core of numerous natural products and pharmaceutical drugs.<sup>[1][2]</sup> This guide focuses on a specific, synthetically challenging derivative: **5-Cyano-5-methyl-2-pyrrolidone**. Its significance lies in the C5 quaternary stereocenter—a carbon atom bonded to four distinct non-hydrogen substituents. The creation and absolute control of such centers represent a formidable challenge in synthetic chemistry and are critical for unlocking the therapeutic potential of novel molecular entities.<sup>[3][4]</sup> This document serves as a technical resource for researchers, scientists, and drug development professionals, providing in-depth insights into the stereochemical analysis, stereoselective synthesis, and analytical characterization of **5-Cyano-5-methyl-2-pyrrolidone**.

## Molecular Architecture: The C5 Quaternary Stereocenter

**5-Cyano-5-methyl-2-pyrrolidone**, with the chemical formula  $C_6H_8N_2O$  and a molecular weight of 124.1405 g/mol, possesses a single stereogenic center at the C5 position.<sup>[5]</sup> This carbon is unique as it is bonded to four different groups:

- A methyl group (-CH<sub>3</sub>)
- A cyano group (-C≡N)
- The ring nitrogen atom (part of the lactam)
- The C4 methylene group of the pyrrolidone ring

This arrangement makes the C5 carbon a quaternary stereocenter, giving rise to two non-superimposable mirror images, or enantiomers: (R)-**5-Cyano-5-methyl-2-pyrrolidone** and (S)-**5-Cyano-5-methyl-2-pyrrolidone**. The construction of such all-carbon quaternary centers is a recognized challenge in organic synthesis due to the steric hindrance involved.<sup>[3][6][7]</sup> The cyano and methyl groups provide distinct electronic and steric properties, making this molecule a versatile chiral building block for further elaboration in drug design.

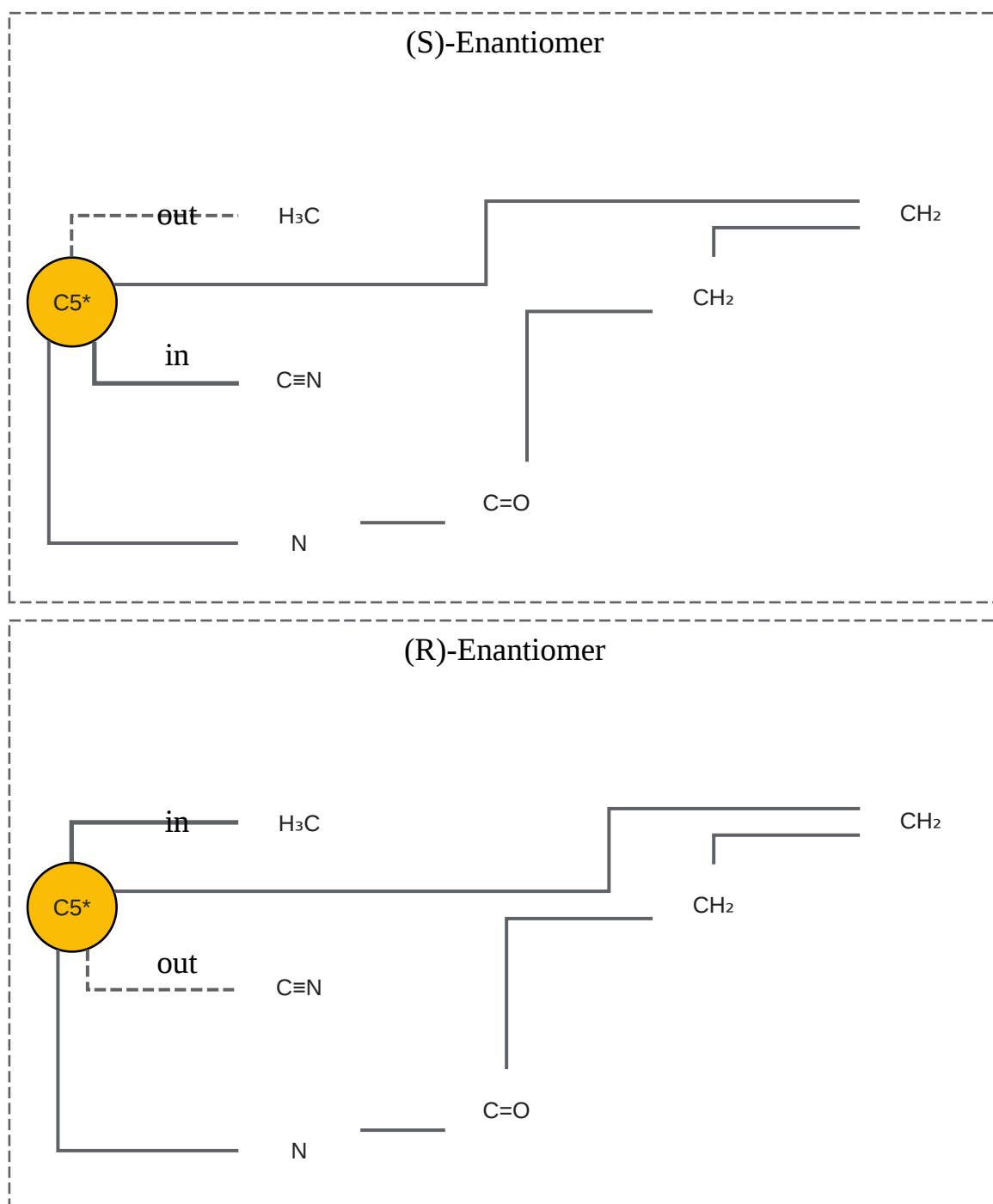

[Click to download full resolution via product page](#)

Caption: Enantiomers of **5-Cyano-5-methyl-2-pyrrolidone** highlighting the C5 stereocenter.

## Strategies for Stereoselective Synthesis

Achieving an enantiomerically pure form of **5-Cyano-5-methyl-2-pyrrolidone** requires a carefully designed synthetic strategy. The choice of pathway depends on factors such as precursor availability, scalability, and the desired level of enantiomeric excess (e.e.).

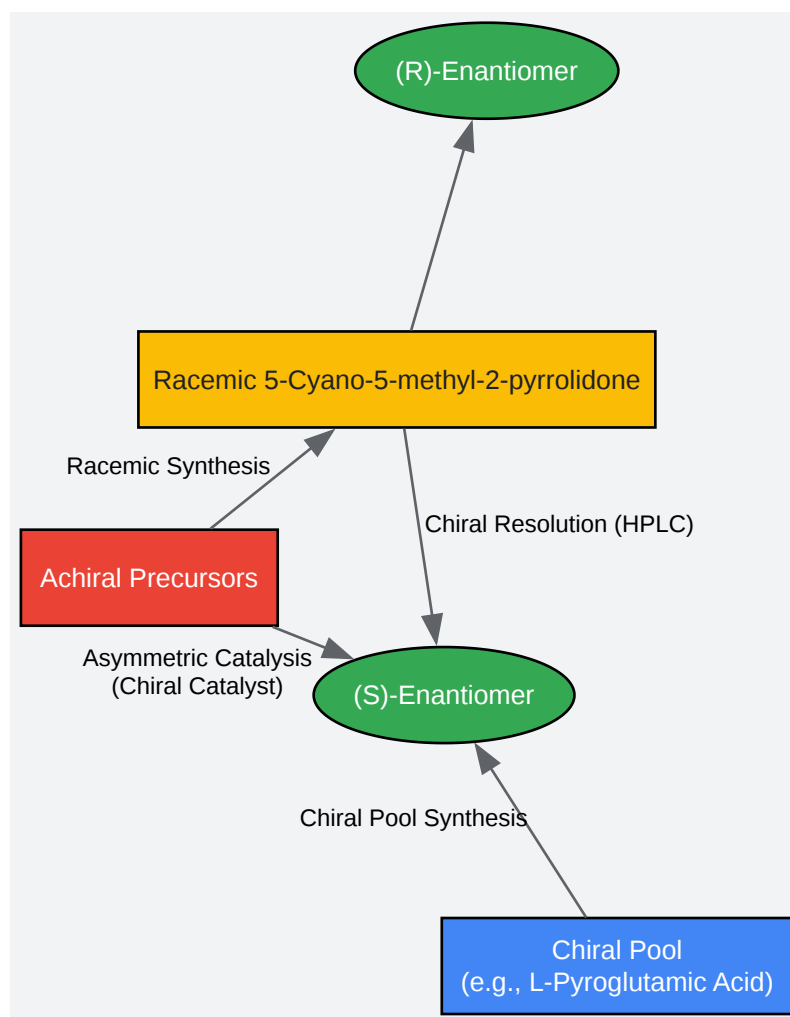

[Click to download full resolution via product page](#)

Caption: Major synthetic routes to enantiomerically enriched **5-Cyano-5-methyl-2-pyrrolidone**.

## Asymmetric Catalysis: Building Chirality from the Ground Up

The most elegant approach is asymmetric catalysis, where a small amount of a chiral catalyst directs the formation of one enantiomer over the other from an achiral starting material.

Causality Behind Experimental Choice: This method is highly atom-economical and scalable. The challenge lies in developing a catalyst and reaction conditions that can effectively control the stereochemistry of a sterically congested quaternary center. A plausible strategy involves the asymmetric cyanation of a 5-methyl-2-pyrrolidone-derived precursor. Recent advances in the synthesis of chiral pyrrolidines have shown success with intramolecular C-H amination or cycloaddition reactions.<sup>[2][8][9]</sup>

#### Exemplary Protocol: Organocatalytic Asymmetric Michael Addition-Cyclization

This protocol is based on established methods for synthesizing substituted pyrrolidines bearing a quaternary center at the 3-position, adapted for the C5 position.<sup>[7]</sup>

- **Precursor Synthesis:** Synthesize the Michael acceptor, 5-methyl-1-aza-1,3-diene, from 5-methyl-2-pyrrolidone via standard methods.
- **Catalyst Preparation:** To a flame-dried Schlenk flask under an inert atmosphere (N<sub>2</sub> or Ar), add the Cinchona-derived squaramide catalyst (10 mol%).
- **Reaction Setup:** Dissolve the Michael acceptor (1.0 equiv) in anhydrous toluene (0.1 M). Add trimethylsilyl cyanide (TMSCN) (1.5 equiv) as the cyanide source.
- **Initiation and Monitoring:** Cool the mixture to -20 °C and add the catalyst. Stir the reaction at this temperature and monitor its progress by thin-layer chromatography (TLC) or LC-MS.
- **Workup:** Upon completion, quench the reaction with a saturated aqueous solution of NaHCO<sub>3</sub>. Extract the aqueous layer with dichloromethane (3x). Combine the organic layers, dry over anhydrous Na<sub>2</sub>SO<sub>4</sub>, filter, and concentrate under reduced pressure.
- **Purification:** Purify the crude product by flash column chromatography on silica gel to yield the enantiomerically enriched **5-Cyano-5-methyl-2-pyrrolidone**.
- **Analysis:** Determine the enantiomeric excess (e.e.) using chiral HPLC analysis (see Section 3.1).

## Chiral Resolution: Separating a Racemic Mixture

When a stereoselective synthesis is not feasible, resolution of a racemate is a reliable alternative. High-Performance Liquid Chromatography (HPLC) using a Chiral Stationary Phase (CSP) is the state-of-the-art method for both analytical and preparative-scale separation of enantiomers.[\[10\]](#)[\[11\]](#)

Causality Behind Experimental Choice: Chiral HPLC offers high resolving power and is applicable to a wide range of compounds.[\[12\]](#) The separation relies on the transient formation of diastereomeric complexes between the enantiomers and the chiral selector of the CSP, leading to different retention times. Polysaccharide-based CSPs are particularly effective for a broad spectrum of chiral compounds, including lactams.[\[13\]](#)[\[14\]](#)

#### Protocol: Preparative Chiral HPLC Resolution

- **Racemate Synthesis:** Prepare racemic **5-Cyano-5-methyl-2-pyrrolidone** using a standard, non-stereoselective synthetic route.
- **Column Selection and Equilibration:** Select a polysaccharide-based CSP (e.g., cellulose or amylose derivatives) of an appropriate dimension for preparative scale. Equilibrate the column with the mobile phase (e.g., a mixture of hexane and isopropanol) at a constant flow rate until a stable baseline is achieved.
- **Sample Preparation:** Dissolve the racemic mixture in the mobile phase to create a concentrated solution.
- **Injection and Fraction Collection:** Inject a large volume of the sample onto the column. Monitor the elution profile using a UV detector. Collect the fractions corresponding to each separated enantiomeric peak.
- **Purity Analysis:** Analyze the collected fractions using an analytical chiral HPLC method to confirm the enantiomeric purity of each separated enantiomer.
- **Solvent Removal:** Combine the fractions for each pure enantiomer and remove the solvent under reduced pressure to obtain the isolated, enantiopure products.

## Analytical Characterization of Stereochemistry

Unambiguous determination of enantiomeric purity and absolute configuration is a non-negotiable step in drug development. A multi-pronged analytical approach ensures the highest level of confidence.

## Chiral High-Performance Liquid Chromatography (HPLC)

Chiral HPLC is the gold standard for determining the enantiomeric excess (e.e.) of a chiral sample.

**Trustworthiness of the Protocol:** This method is self-validating. A successful separation of a known racemic mixture (displaying two distinct, baseline-resolved peaks of equal area) confirms the method's suitability. The analysis of an unknown sample on this validated system provides a trustworthy quantification of the enantiomeric ratio.

Protocol: Analytical Chiral HPLC Method Development

- **Column Screening:** Screen a set of chiral stationary phases (CSPs), such as those based on cellulose, amylose, and cyclodextrin, with a standard mobile phase (e.g., 90:10 Hexane:Isopropanol).[\[13\]](#)
- **Mobile Phase Optimization:** For the column that shows the best initial separation, optimize the mobile phase composition. Vary the ratio of the non-polar solvent (e.g., hexane) to the polar modifier (e.g., isopropanol, ethanol) to improve resolution and shorten analysis time.
- **Method Validation:** Once optimal conditions are found, inject a certified racemic standard to determine the retention times ( $t_{R1}$ ,  $t_{R2}$ ) and resolution factor ( $R_s$ ).
- **Quantification:** Inject the sample of interest. Calculate the enantiomeric excess using the peak areas ( $A_1$ ,  $A_2$ ) of the two enantiomers:  $e.e. (\%) = |(A_1 - A_2) / (A_1 + A_2)| * 100$

Parameter	Typical Starting Conditions	Optimization Goal
Stationary Phase	Polysaccharide-based (e.g., Chiralcel OD-H)	Baseline resolution ( $R_s > 1.5$ )
Mobile Phase	n-Hexane / Isopropanol (90:10 v/v)	Adjust ratio for optimal resolution/time
Flow Rate	1.0 mL/min	Maintain efficiency, adjust as needed
Detection	UV at 210 nm	Maximize signal-to-noise ratio
Column Temp.	25 °C	Can be varied to improve separation

## Vibrational Circular Dichroism (VCD): Assigning Absolute Configuration

While HPLC can quantify the ratio of enantiomers, it cannot assign their absolute configuration (R or S). Vibrational Circular Dichroism (VCD) is a powerful spectroscopic technique that provides this crucial information by measuring the differential absorption of left and right circularly polarized infrared light.<sup>[15][16][17]</sup>

**Authoritative Grounding:** The absolute configuration is determined by comparing the experimentally measured VCD spectrum with spectra predicted by quantum mechanical calculations (typically Density Functional Theory, DFT) for each enantiomer.<sup>[18][19]</sup> A match between the experimental and the calculated spectrum for, say, the (R)-enantiomer, provides a confident assignment of the absolute configuration.

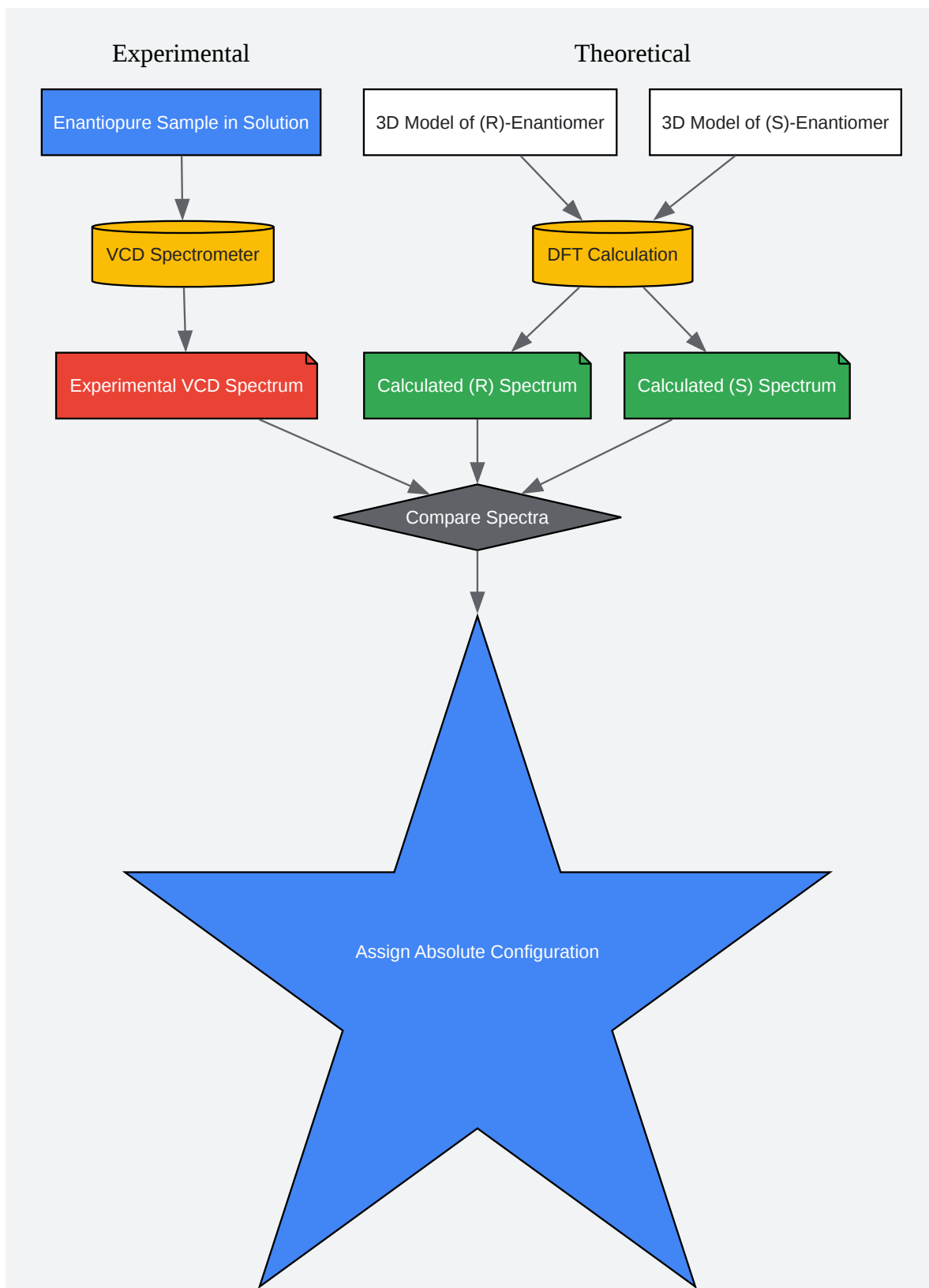

[Click to download full resolution via product page](#)

Caption: Workflow for determining absolute configuration using VCD spectroscopy.

### Protocol: VCD Analysis

- **Sample Preparation:** Prepare a solution of the enantiomerically pure sample in a suitable deuterated solvent (e.g.,  $\text{CDCl}_3$ ) at a concentration sufficient for VCD measurement.
- **Data Acquisition:** Acquire the VCD and IR absorption spectra of the sample using a VCD spectrometer.
- **Computational Modeling:** Generate low-energy conformers for both the (R) and (S) enantiomers of **5-Cyano-5-methyl-2-pyrrolidone** in silico.
- **Spectrum Calculation:** For each conformer, perform a geometry optimization and frequency calculation using DFT (e.g., B3LYP functional with a 6-31G(d) basis set). Calculate the VCD and IR spectra, which are then Boltzmann-averaged according to the relative energies of the conformers.
- **Comparison and Assignment:** Compare the experimental VCD spectrum with the calculated spectra for the (R) and (S) enantiomers. A visual match in the sign and relative intensity of the key bands allows for an unambiguous assignment of the absolute configuration.

## NMR Spectroscopy

While standard  $^1\text{H}$  or  $^{13}\text{C}$  NMR cannot distinguish between enantiomers, it is essential for confirming the relative stereochemistry and overall structure.<sup>[20]</sup> To resolve enantiomers, chiral auxiliary agents can be used.

- **Chiral Solvating Agents (CSAs):** Adding a CSA to the NMR sample can induce small, measurable differences in the chemical shifts of the enantiomers due to the formation of transient, diastereomeric solvates.
- **Chiral Derivatizing Agents (CDAs):** Reacting the molecule with a CDA creates a covalent diastereomeric mixture, which will exhibit distinct signals in the NMR spectrum, allowing for quantification.
- **Nuclear Overhauser Effect (NOE):** For more complex derivatives of this scaffold, 2D NOESY experiments can help determine the relative stereochemistry by identifying protons that are close in space.

## Relevance and Application in Drug Discovery

The stereochemical configuration of a drug is paramount to its interaction with chiral biological targets like enzymes and receptors.[21][22]

- **Pharmacological Activity:** One enantiomer may exhibit the desired therapeutic effect while the other could be inactive, less active, or cause undesirable side effects.
- **Versatile Intermediate:** The **5-Cyano-5-methyl-2-pyrrolidone** scaffold is a valuable building block. The cyano group can be readily transformed into other functional groups, such as a carboxylic acid (via hydrolysis) or an amine (via reduction), opening pathways to a diverse range of more complex chiral molecules.
- **Physicochemical Properties:** The introduction of a defined stereocenter can influence properties like solubility and crystal packing, which are critical for drug formulation and bioavailability.

## Conclusion

The stereochemistry of **5-Cyano-5-methyl-2-pyrrolidone**, centered on its C5 quaternary carbon, presents both a significant synthetic challenge and a valuable opportunity in medicinal chemistry. Mastery over its stereoselective synthesis is key to unlocking its potential as a chiral building block for novel therapeutics. A rigorous and multi-faceted analytical approach, combining chiral chromatography for purity assessment with chiroptical methods like VCD for absolute configuration assignment, is essential for ensuring the quality and safety of any resulting drug candidate. This guide provides the foundational principles and practical methodologies required for researchers to confidently navigate the complexities of this important chiral scaffold.

## References

- BenchChem. (2025). Chiral Synthesis of 5-Hydroxy-2-pyrrolidone: An In-depth Technical Guide for Researchers and Drug Development Professionals. Benchchem.com.
- NIST. (n.d.). **5-Cyano-5-methyl-2-pyrrolidone**. NIST WebBook. [[Link](#)]
- Freifeld, I., Armbrust, H., & Langer, P. (2006). Synthesis of 5-(Hydroxymethyl)pyrrolidin-2-ones by Cyclization of Amide Dianions with Epibromohydrin. *Synthesis*, 2006(11), 1807-

1808. [\[Link\]](#)

- Google Patents. (2019). Synthetic method of 5-methyl-2-pyrrolidone. CN110615754A.
- PubChem. (n.d.). 5-Methyl-2-pyrrolidone. National Center for Biotechnology Information. [\[Link\]](#)
- Puschmann, F. F., et al. (2019). methyl (Z)-5-(2-tert-butoxy-1-cyano-2-oxoethylidene)pyrrolidine-2-carboxylate, a compound with low resonant scattering. Acta Crystallographica Section E: Crystallographic Communications, 75(Pt 10), 1493–1498. [\[Link\]](#)
- Google Patents. (2005). Production of 5-methyl-N-(methyl aryl)-2-pyrrolidone, 5-methyl-N-(methyl cycloalkyl)-2-pyrrolidone and 5-methyl-N-alkyl-2-pyrrolidone by reductive amination of levulinic acid esters with cyano compounds. US20050059829A1.
- Lazib, Y., et al. (2021). Asymmetric Syntheses of Enantioenriched 2,5-Disubstituted Pyrrolidines. Molecules, 26(16), 4938. [\[Link\]](#)
- Nagib, D. A., et al. (2014). Chiral pyrrolidines via an enantioselective Hofmann-Löffler-Freytag reaction. Nature Chemistry, 6(4), 324-330. [\[Link\]](#)
- Al-Qaisi, A. M., & Tutunji, M. F. (2005). Separation of Enantiomers of  $\beta$ -Lactams by HPLC Using Cyclodextrin-Based Chiral Stationary Phases. Journal of Liquid Chromatography & Related Technologies, 28(12), 1851-1865. [\[Link\]](#)
- Al-Harrasi, A., et al. (2012). A simple asymmetric synthesis of 2-substituted pyrrolidines and 5-substituted pyrrolidinones. The Journal of Organic Chemistry, 77(17), 7548-7555. [\[Link\]](#)
- Shintani, R., et al. (2012). Palladium-catalyzed asymmetric synthesis of 2-pyrrolidinones with a quaternary carbon stereocenter. Chemical Communications, 48(80), 9936-9938. [\[Link\]](#)
- Wikipedia. (n.d.). Vibrational circular dichroism. [\[Link\]](#)
- Kumar, A., et al. (2021). Pyrrolidine in Drug Discovery: A Versatile Scaffold for Novel Biologically Active Compounds. Current Organic Chemistry, 25(10), 1218-1240. [\[Link\]](#)
- ResearchGate. (n.d.). <sup>1</sup>H-NMR spectrum of 1-pyrroline solution in DMSO-d 6 (10000 ppm). [\[Link\]](#)

- Subramanian, G. (2007). A Strategy for Developing HPLC Methods for Chiral Drugs. LCGC International. [\[Link\]](#)
- Bruker. (n.d.). Vibrational circular dichroism (VCD). [\[Link\]](#)
- Corey, E. J., & Guzman-Perez, A. (1998). The catalytic enantioselective construction of molecules with quaternary carbon stereocenters. *Angewandte Chemie International Edition*, 37(4), 388-401. [\[Link\]](#)
- PubMed. (2020). Determining the Regiochemistry and Relative Stereochemistry of Small and Druglike Molecules Using an Alignment Algorithm for Infrared Spectra. [\[Link\]](#)
- YouTube. (2023). Locate the stereogenic centers in each drug. [\[Link\]](#)
- Hinds Instruments. (n.d.). Vibrational Circular Dichroism. [\[Link\]](#)
- Royal Society of Chemistry. (n.d.). Synthesis and Structural Characterization of Amido Heteroscorpionate Rare-Earth Metals Complexes. Hydroamination of Aminoalkenes. [\[Link\]](#)
- Zhang, H., et al. (2023). Application of Chiral Piperidine Scaffolds in Drug Design. *Synthesis*, 55(10), 1547-1563. [\[Link\]](#)
- Reddy, R. S., et al. (2015). Organocatalytic asymmetric synthesis of highly substituted pyrrolidines bearing a stereogenic quaternary centre at the 3-position. *Organic & Biomolecular Chemistry*, 13(28), 7670-7674. [\[Link\]](#)
- Carreira, E. M. (2017). A new path to enantioselective substituted pyrrolidines. *Mapping Ignorance*. [\[Link\]](#)
- Phenomenex. (n.d.). Chiral HPLC Column. [\[Link\]](#)
- MDPI. (n.d.). Stereogenic Centers. [\[Link\]](#)
- Åkesson, B., & Jönsson, B. A. (2000). Biological Monitoring of N-methyl-2-pyrrolidone Using 5-hydroxy-N-methyl-2-pyrrolidone in Plasma and Urine as the Biomarker. *Scandinavian Journal of Work, Environment & Health*, 26(4), 325-331. [\[Link\]](#)
- Restek. (n.d.). A Guide to the Analysis of Chiral Compounds by GC. [\[Link\]](#)

- PubMed. (2023). Vibrational Circular Dichroism Spectroscopy of Chiral Molecular Crystals: Insights from Theory. [\[Link\]](#)
- ResearchGate. (2023). Application of Chiral Piperidine Scaffolds in Drug Design. [\[Link\]](#)
- Harned Research Group. (n.d.). NMR and Stereochemistry. [\[Link\]](#)
- Ilisz, I., et al. (2021). An overview of chiral separations of pharmaceutically active substances by HPLC (2018–2020). *Monatshefte für Chemie - Chemical Monthly*, 152(6), 665-680. [\[Link\]](#)
- ResearchGate. (2015). Vibrational Circular Dichroism: A New Tool for the Solution-State Determination of the Structure and Absolute Configuration of Chiral Natural Product Molecules. [\[Link\]](#)
- Agilent. (2024). Purity Analysis of N-Methyl Pyrrolidone (NMP) Using an Agilent 8850 GC. [\[Link\]](#)
- MDPI. (n.d.). Progress in the Stereoselective Synthesis Methods of Pyrrolidine-Containing Drugs and Their Precursors. [\[Link\]](#)
- Regis Technologies. (n.d.). Impact of Reversed-Phase Chiral Chromatography on the LC-MS Analysis of Drugs in Biological Fluids. [\[Link\]](#)
- YouTube. (2024). NMR Spectroscopy: Structure Determination Of Organic Compounds. [\[Link\]](#)
- Royal Society of Chemistry. (n.d.). Catalytic asymmetric synthesis of pyrrolidine derivatives bearing heteroatom-substituted quaternary stereocenters. [\[Link\]](#)
- Lammens, T. M., et al. (2010). Synthesis of biobased N-methylpyrrolidone by one-pot cyclization and methylation of  $\gamma$ -aminobutyric acid. *Green Chemistry*, 12(8), 1430-1436. [\[Link\]](#)
- ACS Publications. (2023). Stereoselective Synthesis of Densely Substituted Pyrrolidines via a [3 + 2] Cycloaddition Reaction between Chiral N-tert-Butanesulfinylazadienes and Azomethine Ylides. [\[Link\]](#)

### Need Custom Synthesis?

BenchChem offers custom synthesis for rare earth carbides and specific isotopic labeling.

Email: [info@benchchem.com](mailto:info@benchchem.com) or [Request Quote Online](#).

## Sources

- 1. Pyrrolidine in Drug Discovery: A Versatile Scaffold for Novel Biologically Active Compounds - PMC [[pmc.ncbi.nlm.nih.gov](https://pubmed.ncbi.nlm.nih.gov/)]
- 2. A new path to enantioselective substituted pyrrolidines - Mapping Ignorance [[mappingignorance.org](https://mappingignorance.org/)]
- 3. Catalytic asymmetric synthesis of all-carbon quaternary stereocenters - PMC [[pmc.ncbi.nlm.nih.gov](https://pubmed.ncbi.nlm.nih.gov/)]
- 4. [mdpi.com](https://mdpi.com/) [[mdpi.com](https://mdpi.com/)]
- 5. 5-Cyano-5-methyl-2-pyrrolidone [[webbook.nist.gov](https://webbook.nist.gov/)]
- 6. Palladium-catalyzed asymmetric synthesis of 2-pyrrolidinones with a quaternary carbon stereocenter - Chemical Communications (RSC Publishing) [[pubs.rsc.org](https://pubs.rsc.org/)]
- 7. Organocatalytic asymmetric synthesis of highly substituted pyrrolidines bearing a stereogenic quaternary centre at the 3-position - Organic & Biomolecular Chemistry (RSC Publishing) [[pubs.rsc.org](https://pubs.rsc.org/)]
- 8. Asymmetric Syntheses of Enantioenriched 2,5-Disubstituted Pyrrolidines - PMC [[pmc.ncbi.nlm.nih.gov](https://pubmed.ncbi.nlm.nih.gov/)]
- 9. Chiral pyrrolidines via an enantioselective Hofmann-Löffler-Freytag reaction - PMC [[pmc.ncbi.nlm.nih.gov](https://pubmed.ncbi.nlm.nih.gov/)]
- 10. [chromatographyonline.com](https://chromatographyonline.com/) [[chromatographyonline.com](https://chromatographyonline.com/)]
- 11. An overview of chiral separations of pharmaceutically active substances by HPLC (2018–2020) - PMC [[pmc.ncbi.nlm.nih.gov](https://pubmed.ncbi.nlm.nih.gov/)]
- 12. Chiral HPLC Column | Phenomenex [[phenomenex.com](https://phenomenex.com/)]
- 13. [researchgate.net](https://researchgate.net/) [[researchgate.net](https://researchgate.net/)]
- 14. [lcms.cz](https://lcms.cz/) [[lcms.cz](https://lcms.cz/)]
- 15. Vibrational circular dichroism - Wikipedia [[en.wikipedia.org](https://en.wikipedia.org/)]
- 16. VCD - Vibrational Circular Dichroism | Bruker [[bruker.com](https://bruker.com/)]

- [17. hindsinstruments.com \[hindsinstruments.com\]](https://hindsinstruments.com)
- [18. Vibrational Circular Dichroism Spectroscopy of Chiral Molecular Crystals: Insights from Theory - PubMed \[pubmed.ncbi.nlm.nih.gov\]](https://pubmed.ncbi.nlm.nih.gov)
- [19. researchgate.net \[researchgate.net\]](https://researchgate.net)
- [20. m.youtube.com \[m.youtube.com\]](https://m.youtube.com)
- [21. thieme-connect.com \[thieme-connect.com\]](https://thieme-connect.com)
- [22. researchgate.net \[researchgate.net\]](https://researchgate.net)
- To cite this document: BenchChem. [Foreword: The Imperative of Chirality in Modern Drug Discovery]. BenchChem, [2026]. [Online PDF]. Available at: [\[https://www.benchchem.com/product/b1330294/docs#foreword-the-imperative-of-chirality-in-modern-drug-discovery\]](https://www.benchchem.com/product/b1330294/docs#foreword-the-imperative-of-chirality-in-modern-drug-discovery)

---

#### Disclaimer & Data Validity:

The information provided in this document is for Research Use Only (RUO) and is strictly not intended for diagnostic or therapeutic procedures. While BenchChem strives to provide accurate protocols, we make no warranties, express or implied, regarding the fitness of this product for every specific experimental setup.

**Technical Support:** The protocols provided are for reference purposes. Unsure if this reagent suits your experiment?

**Need Industrial/Bulk Grade?** [Request Custom Synthesis Quote](#)

## BenchChem

Our mission is to be the trusted global source of essential and advanced chemicals, empowering scientists and researchers to drive progress in science and industry.

#### Contact

Address: 3281 E Guasti Rd

Ontario, CA 91761, United States

Phone: (601) 213-4426

Email: [info@benchchem.com](mailto:info@benchchem.com)

Contact our Ph.D. Support Team for a compatibility check