

A Comparative Guide to Alternative Reagents for Formamidine Synthesis

Author: BenchChem Technical Support Team. **Date:** May 2026

Compound of Interest

Compound Name: *N*-(2-Chloro-5-(trifluoromethyl)phenyl)formamide

CAS No.: 657-63-6

Cat. No.: B1330299

[Get Quote](#)

For researchers, scientists, and professionals in drug development, the synthesis of formamidines is a crucial step in the creation of a wide array of biologically active molecules and pharmaceutical intermediates. While phenyl chloroformate has been utilized for this purpose, a range of alternative reagents offer distinct advantages in terms of yield, reaction conditions, safety, and substrate scope. This guide provides an objective comparison of key alternatives to phenyl chloroformate for formamidine synthesis, supported by experimental data and detailed protocols.

Executive Summary

The choice of reagent for formamidine synthesis is critical and depends on factors such as the desired substitution pattern of the formamidine, the nature of the starting amine, and the desired reaction conditions. This guide explores the following alternatives to phenyl chloroformate:

- **Triethyl Orthoformate:** A classic and versatile reagent for the synthesis of *N,N'*-disubstituted formamidines from primary amines.

- N,N-Dimethylformamide Dimethyl Acetal (DMF-DMA): A milder reagent, particularly useful for generating N,N-dimethylformamidines from primary and secondary amines.
- Vilsmeier-Haack Reagent: A highly reactive electrophile, effective for the formylation of a wide range of amines to produce formamidines.
- Brederick's Reagent: A powerful aminomethylenating agent, advantageous for less reactive substrates.

This comparison will delve into the performance of each reagent, providing a clear overview to aid in the selection of the most appropriate synthetic route.

Performance Comparison of Formamidine Synthesis Reagents

The following table summarizes the performance of different reagents for the synthesis of N,N'-diphenylformamidine from aniline as a representative substrate.

Reagent/Method	Reaction Conditions	Yield (%)	Reference
Phenyl Chloroformate/DMF	Aniline, Phenyl Chloroformate, DMF, Room Temperature, 5 min	95	[1]
Triethyl Orthoformate	Aniline, Triethyl Orthoformate, FeCl ₃ (cat.), Toluene, Room Temperature, 3 h	92	[2]
Triethyl Orthoformate	Aniline, Triethyl Orthoformate, Ceric Ammonium Nitrate (cat.), Water, Room Temperature	High Yield	[3]
Triethyl Orthoformate	Aniline, Triethyl Orthoformate, Ultrasound, Solvent-Free, Room Temperature	Excellent Yields	[4]
Vilsmeier-Haack Reagent	2-Aminothiophene derivative, POCl ₃ , DMF, 0 °C to RT, 30 min	90	[5]
DMF-DMA	2-Aminothiophene derivative, DMF-DMA, Reflux, 5 h	75	[5]

Note: Direct comparative data for all reagents with the same substrate under identical conditions is limited. The data presented is collated from various sources to provide a representative comparison.

Alternative Reagents and Experimental Protocols

Triethyl Orthoformate

Triethyl orthoformate is a widely used and cost-effective reagent for the synthesis of N,N'-disubstituted formamidines from two equivalents of a primary amine. The reaction typically requires heating and can be catalyzed by acids.

Advantages:

- Readily available and relatively inexpensive.
- Effective for a wide range of primary amines.
- Can be used under solvent-free conditions.[4]

Disadvantages:

- Often requires high temperatures and long reaction times.
- Not suitable for the synthesis of N,N-disubstituted formamidines from secondary amines.

Experimental Protocol: FeCl₃ Catalyzed Synthesis of N,N'-Diphenylformamidine[2]

- To a well-stirred solution of aniline (186 mg, 2 mmol) and triethyl orthoformate (148 mg, 1 mmol) in toluene (10 mL), add a catalytic amount of FeCl₃ (10 mol%).
- Stir the mixture for 3 hours at room temperature.
- Remove the solvent under reduced pressure.
- Dissolve the resulting solid mass in chloroform (30 mL) and filter.
- The filtrate is concentrated and the crude product is purified by column chromatography on silica gel to afford pure N,N'-diphenylformamidine.

Reaction Pathway:

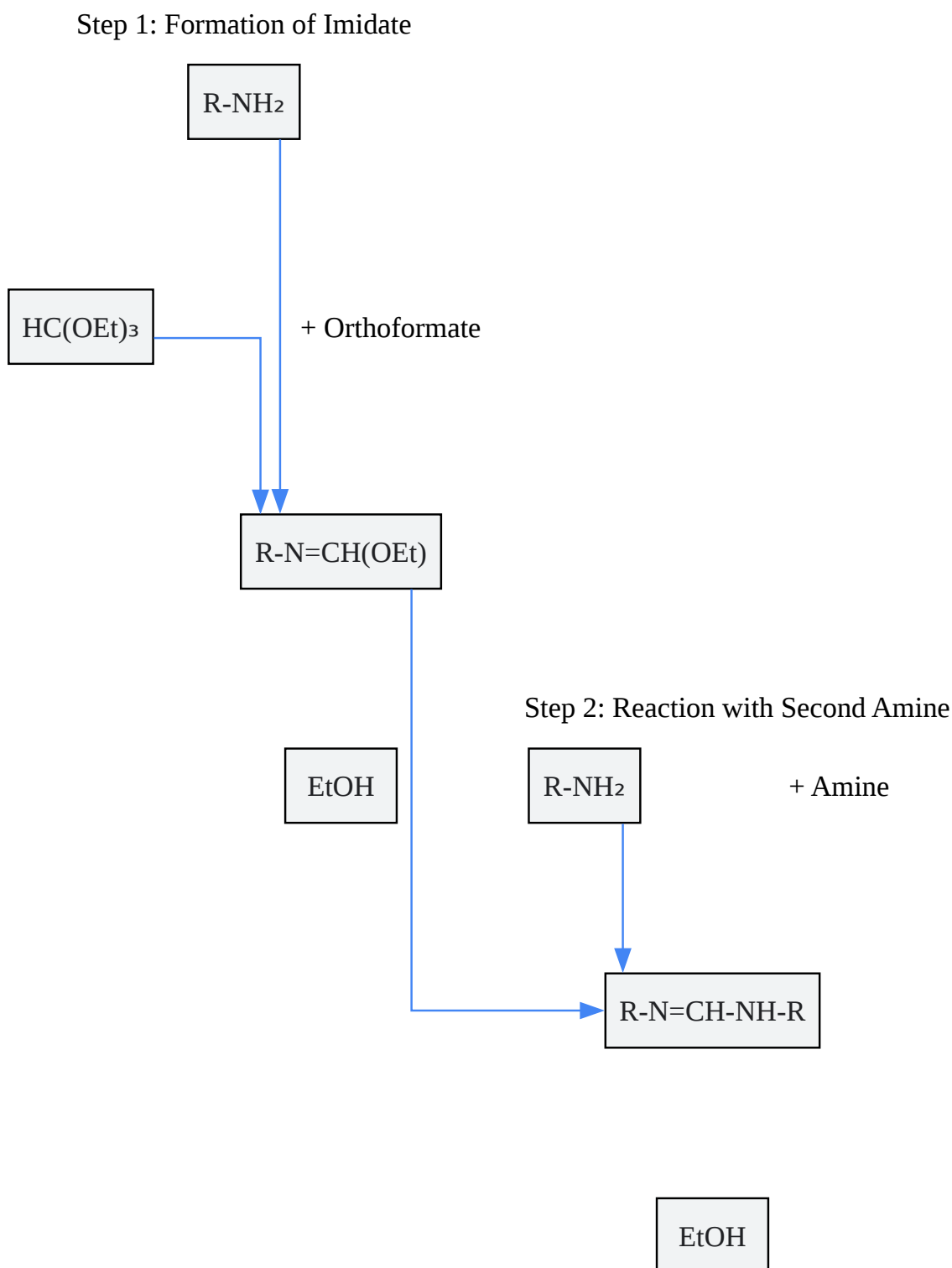

[Click to download full resolution via product page](#)

Caption: Synthesis of N,N'-disubstituted formamidine using triethyl orthoformate.

N,N-Dimethylformamide Dimethyl Acetal (DMF-DMA)

DMF-DMA is a milder alternative that serves as a one-carbon synthon, reacting with primary and secondary amines to form N,N-dimethylformamidine derivatives. It is particularly useful when working with acid-sensitive substrates.[6]

Advantages:

- Milder reaction conditions, often at room temperature or with gentle heating.[6]
- Suitable for both primary and secondary amines.
- Cleaner reactions with volatile byproducts (methanol and dimethylamine), simplifying workup.[6]

Disadvantages:

- Can be less reactive than other reagents, sometimes requiring longer reaction times or heating.[5]
- Primarily yields N,N-dimethylformamidines.

Experimental Protocol: Synthesis of an N'-(2-cyanoaryl)-N,N-dimethylformamidine intermediate[7]

- In a microwave-safe reaction vessel, combine the substituted 2-aminobenzonitrile (1.0 eq) and DMF-DMA (which acts as both reactant and solvent).
- Seal the vessel and place it in a microwave reactor.
- Irradiate the mixture at 105 °C for 15 minutes.
- After cooling, the resulting N'-(2-cyanoaryl)-N,N-dimethylformamidine intermediate can be used in the subsequent step without further purification.

Reaction Pathway:

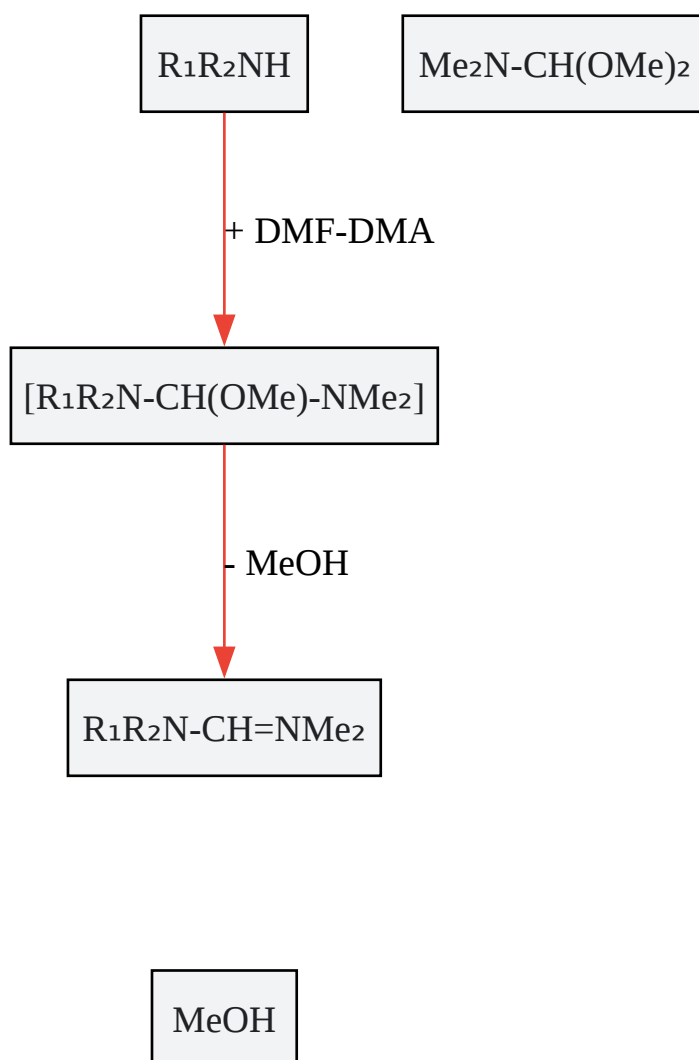

[Click to download full resolution via product page](#)

Caption: Synthesis of N,N-disubstituted formamidine using DMF-DMA.

Vilsmeier-Haack Reagent

The Vilsmeier-Haack reagent, typically generated in situ from phosphorus oxychloride ($POCl_3$) and N,N-dimethylformamide (DMF), is a highly electrophilic species that readily reacts with amines to form formamidines.

Advantages:

- High reactivity, leading to shorter reaction times and high yields.[5]
- Effective for a broad range of substrates, including less reactive amines.

- Thermodynamically more favorable than DMF-DMA in some cases.[5]

Disadvantages:

- Harsh and corrosive nature of POCl_3 requires careful handling.[6]
- The high reactivity can lead to side reactions with sensitive functional groups.[6]

Experimental Protocol: General Procedure for Formamidinium Synthesis[5]

- In a round-bottom flask, place N,N-dimethylformamide (DMF).
- Cool the flask in an ice bath and slowly add phosphorus oxychloride (POCl_3) with stirring to form the Vilsmeier reagent.
- To this mixture, add the primary amine substrate.
- Stir the reaction mixture at room temperature.
- After completion of the reaction (monitored by TLC), the mixture is quenched with a base (e.g., aqueous sodium hydroxide) and the product is extracted with an organic solvent.
- The organic layer is dried and concentrated to give the crude formamidinium, which is then purified.

Reaction Pathway:

Vilsmeier Reagent Formation

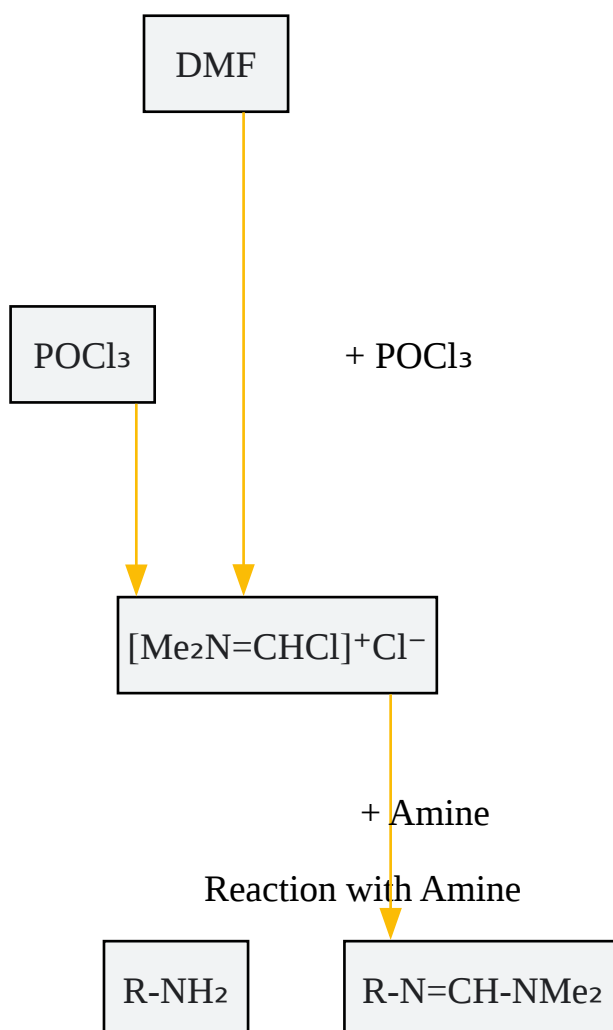

[Click to download full resolution via product page](#)

Caption: Formamidine synthesis via the Vilsmeier-Haack reagent.

Bredereck's Reagent

Bredereck's reagent (tert-butoxybis(dimethylamino)methane) is a powerful aminomethylenating agent that is particularly effective for reacting with compounds containing active methylene groups. It can also be used for the synthesis of formamidines, especially with less acidic substrates where other reagents may fail.[8]

Advantages:

- Higher reactivity compared to DMF-DMA, especially with less acidic substrates.[8]
- Generates a strong base (tert-butoxide) in situ, facilitating the reaction.
- Bench-stable and can be handled more easily than the Vilsmeier reagent.

Disadvantages:

- More expensive than other alternatives.
- The reaction often requires heating to reflux.

Experimental Protocol: General Aminomethylenation of Active Methylene Compounds[8]

- In a round-bottom flask equipped with a reflux condenser and a nitrogen inlet, dissolve the active methylene compound (1.0 equiv) in an anhydrous, non-polar aprotic solvent (e.g., toluene).
- Add Brederick's reagent (1.1 - 1.5 equiv) to the solution.
- Heat the reaction mixture to reflux under a nitrogen atmosphere.
- Monitor the reaction progress by Thin Layer Chromatography (TLC).
- Upon completion, the solvent is removed under reduced pressure, and the resulting enamine product can be further purified or used directly.

Reaction Pathway:

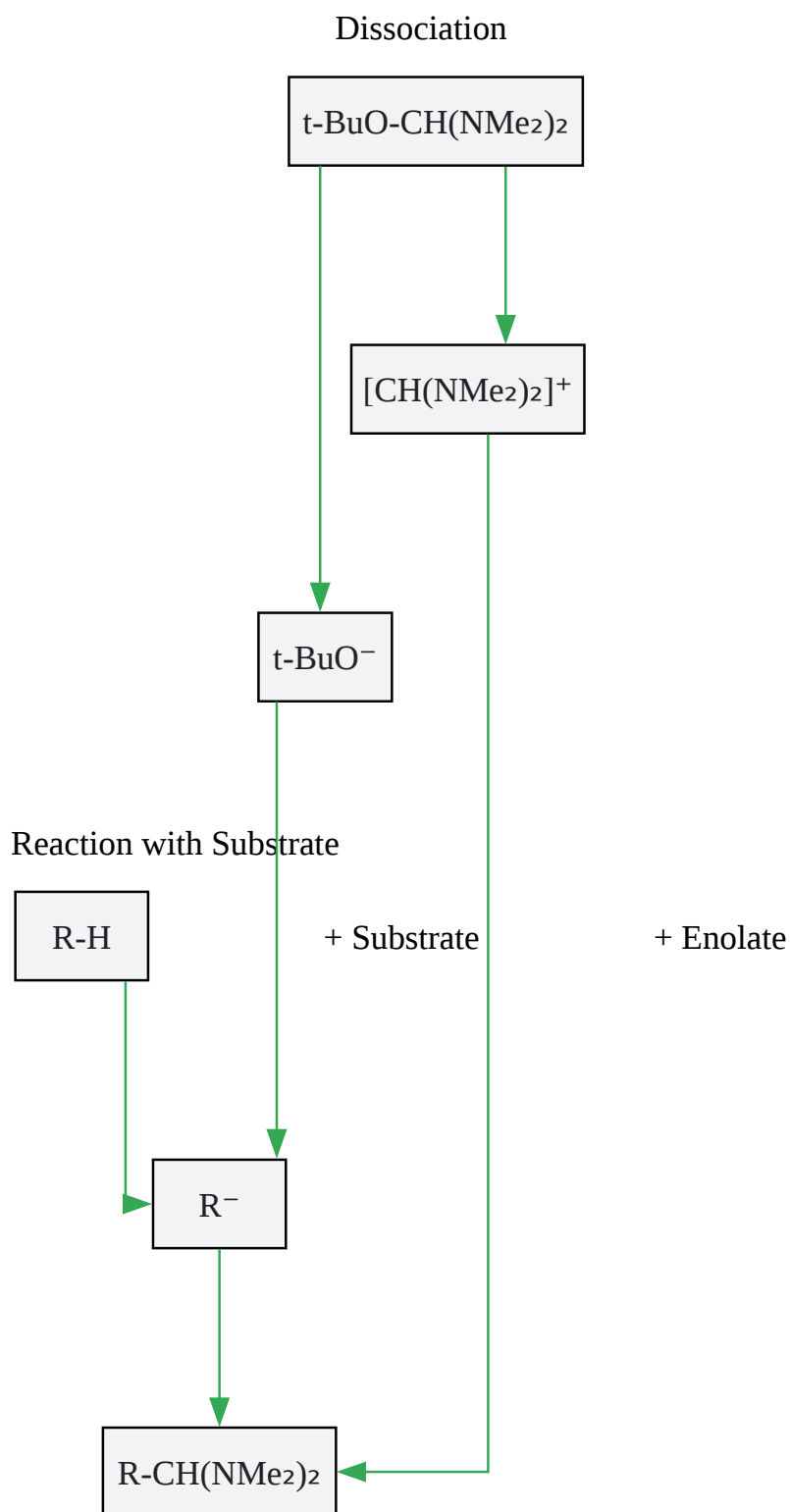

[Click to download full resolution via product page](#)

Caption: Reaction mechanism of Brederick's reagent.

Conclusion

The synthesis of formamidines can be achieved through various synthetic routes, each with its own set of advantages and limitations. While phenyl chloroformate offers a rapid and high-yielding method, concerns about its toxicity and handling may lead researchers to seek alternatives.

- Triethyl orthoformate stands out as a classic, economical, and versatile reagent, particularly for N,N'-diarylformamidines, with recent improvements using catalysts or ultrasound to enhance its efficiency under milder conditions.
- DMF-DMA provides a gentler approach, ideal for substrates that are sensitive to harsh acidic conditions, and offers a straightforward workup.
- The Vilsmeier-Haack reagent is a powerful and highly reactive option that ensures high yields and short reaction times, making it suitable for a broad range of amines.
- Brederick's reagent excels in cases where substrates are less reactive, demonstrating superior performance over milder reagents like DMF-DMA.

The selection of the optimal reagent will ultimately be guided by the specific requirements of the target molecule, including the nature of the amine substrate, desired substitution pattern, and tolerance to different reaction conditions. This guide provides the necessary comparative data and protocols to assist researchers in making an informed decision for their synthetic endeavors.

Need Custom Synthesis?

BenchChem offers custom synthesis for rare earth carbides and specific isotopic labeling.

Email: info@benchchem.com or [Request Quote Online](#).

References

- [1. researchgate.net \[researchgate.net\]](#)
- [2. An Efficient FeCl₃ Catalyzed Synthesis of N,N'-Diarylformamidines \[scirp.org\]](#)

- [3. researchgate.net \[researchgate.net\]](#)
- [4. researchgate.net \[researchgate.net\]](#)
- [5. COMPARATIVE STUDY OF VILSMEIER–HAACK REAGENT AND DMF–DMA IN THE SYNTHESIS OF 2-AMINOTHIOPHENE-BASED FORMAMIDINE DERIVATIVES | Chemistry of Heterocyclic Compounds \[hgs.osi.lv\]](#)
- [6. benchchem.com \[benchchem.com\]](#)
- [7. benchchem.com \[benchchem.com\]](#)
- [8. benchchem.com \[benchchem.com\]](#)
- To cite this document: BenchChem. [A Comparative Guide to Alternative Reagents for Formamide Synthesis]. BenchChem, [2026]. [Online PDF]. Available at: [\[https://www.benchchem.com/product/b1330299/docs#a-comparative-guide-to-alternative-reagents-for-formamide-synthesis\]](https://www.benchchem.com/product/b1330299/docs#a-comparative-guide-to-alternative-reagents-for-formamide-synthesis)

Disclaimer & Data Validity:

The information provided in this document is for Research Use Only (RUO) and is strictly not intended for diagnostic or therapeutic procedures. While BenchChem strives to provide accurate protocols, we make no warranties, express or implied, regarding the fitness of this product for every specific experimental setup.

Technical Support: The protocols provided are for reference purposes. Unsure if this reagent suits your experiment?

Need Industrial/Bulk Grade? [Request Custom Synthesis Quote](#)

BenchChem

Our mission is to be the trusted global source of essential and advanced chemicals, empowering scientists and researchers to drive progress in science and industry.

Contact

Address: 3281 E Guasti Rd
Ontario, CA 91761, United States
Phone: (601) 213-4426
Email: info@benchchem.com

Contact our Ph.D. Support Team for a compatibility check