

3-Chloro-4-(2-chlorophenoxy)aniline chemical structure

Author: BenchChem Technical Support Team. **Date:** May 2026

Compound of Interest

Compound Name: 3-Chloro-4-(2-chlorophenoxy)aniline

CAS No.: 56966-54-2

Cat. No.: B1330836

[Get Quote](#)

An In-depth Technical Guide to **3-Chloro-4-(2-chlorophenoxy)aniline**

Executive Summary

This technical guide provides a comprehensive overview of **3-Chloro-4-(2-chlorophenoxy)aniline**, a diaryl ether aniline derivative of significant interest to researchers in medicinal chemistry and materials science. As a key structural motif, this compound serves as a valuable intermediate in the synthesis of complex organic molecules, including potential kinase inhibitors and other biologically active agents. This document details the molecule's identity, physicochemical properties, robust synthetic and purification protocols, and state-of-the-art analytical characterization techniques. Furthermore, it explores its applications in drug development and outlines critical safety and handling procedures. The methodologies described herein are presented with a focus on causality and reproducibility, ensuring that researchers can confidently apply this information in a laboratory setting.

Chapter 1: Molecular Identity and Physicochemical Properties

Nomenclature and Identifiers

The precise identification of a chemical entity is foundational for all research, regulatory, and procurement activities. While specific experimental data for **3-Chloro-4-(2-chlorophenoxy)aniline** is sparse in public literature, its identity can be established through systematic nomenclature and its relationship to well-documented isomers. The properties are often comparable to its widely studied isomer, 3-Chloro-4-(4-chlorophenoxy)aniline (CAS No. 24900-79-6).

Identifier Type	Value / Data	Source
IUPAC Name	3-chloro-4-(2-chlorophenoxy)aniline	Systematic
Molecular Formula	C ₁₂ H ₉ Cl ₂ NO	[1]
Molecular Weight	254.11 g/mol	[1]
Canonical SMILES	<chem>C1=CC=C(C(=C1)OC2=C(C=C(C=C2)N)Cl)Cl</chem>	Inferred
InChI Key	Inferred from structure; Isomer: OQOCWFFSZSSEDS- UHFFFAOYSA-N	[1]
CAS Number	Not explicitly assigned in major databases; Isomer is 24900-79-6	[1]

Chemical Structure

The molecule consists of an aniline ring substituted with a chlorine atom at position 3. The defining feature is the diaryl ether linkage at position 4, connecting the aniline ring to a 2-chlorophenoxy group. This specific substitution pattern dictates the molecule's three-dimensional shape, reactivity, and potential as a pharmacophore.

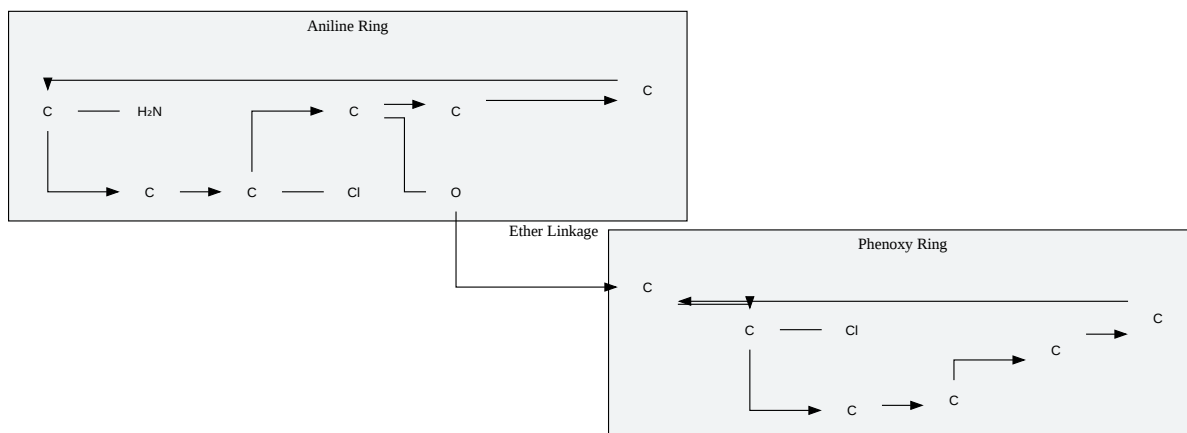

[Click to download full resolution via product page](#)

Caption: 2D structure of **3-Chloro-4-(2-chlorophenoxy)aniline**.

Physicochemical Data

Quantitative physical data for this specific isomer is not readily available. However, data from the isomeric 3-chloro-4-(4-chlorophenoxy)aniline provides a reliable estimate for experimental planning.

Property	Value (for 4-chloro isomer)	Source
Appearance	Pale-yellow or orange solid	[2]
Melting Point	73-77 °C	
Boiling Point	Data not available	
Solubility	Insoluble in water; Soluble in organic solvents (e.g., EtOH, EtOAc, Chloroform)	Inferred

Chapter 2: Synthesis and Purification

The construction of the diaryl ether linkage is the central challenge in synthesizing this molecule. A robust and logical two-step approach involves a nucleophilic aromatic substitution (S_NAr) reaction, such as an Ullmann condensation, followed by the reduction of a nitro group to the target aniline.

Synthetic Workflow Diagram

This workflow illustrates a reliable pathway from commercially available starting materials to the final, purified product.

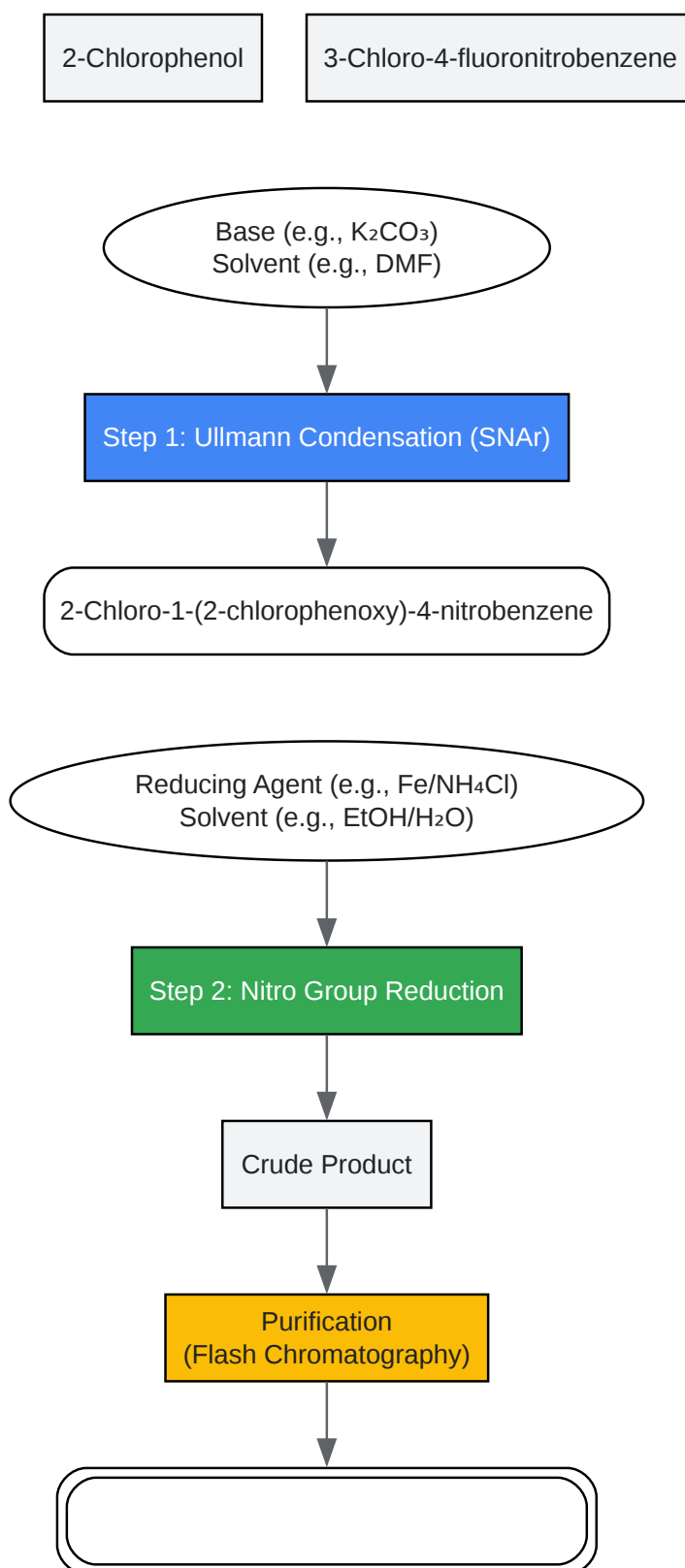

[Click to download full resolution via product page](#)

Caption: A two-step synthetic workflow for the target compound.

Detailed Synthesis Protocol

This protocol is adapted from established procedures for analogous diaryl ethers and is designed for high yield and purity.^{[2][3]}

Step 1: Synthesis of 2-Chloro-1-(2-chlorophenoxy)-4-nitrobenzene

- **Rationale:** This step forms the key diaryl ether bond. A polar aprotic solvent like DMF is chosen to solvate the potassium carbonate base, enhancing the nucleophilicity of the resulting phenoxide. The fluorine atom on the nitrobenzene ring is an excellent leaving group for S_NAr reactions.
- **Materials:**
 - 2-Chlorophenol (1.0 eq)
 - 3-Chloro-4-fluoronitrobenzene (1.0 eq)
 - Potassium Carbonate (K₂CO₃, 1.5 eq), anhydrous
 - Dimethylformamide (DMF), anhydrous
- **Procedure:**
 - To a dry, nitrogen-flushed round-bottom flask, add 2-chlorophenol and anhydrous DMF.
 - Stir the solution and add potassium carbonate in one portion.
 - Add 3-chloro-4-fluoronitrobenzene to the suspension.
 - Heat the reaction mixture to 80-100 °C and monitor by TLC (Thin Layer Chromatography) until the starting material is consumed (typically 4-8 hours).
 - Cool the mixture to room temperature and pour it into ice-water.
 - Extract the aqueous mixture with ethyl acetate (3x).
 - Combine the organic layers, wash with brine, dry over anhydrous sodium sulfate (Na₂SO₄), and concentrate under reduced pressure to yield the crude nitro-intermediate.

Step 2: Reduction to **3-Chloro-4-(2-chlorophenoxy)aniline**

- Rationale: The reduction of the nitro group to an amine is a classic transformation. The use of iron powder in the presence of an acidic catalyst (like ammonium chloride or acetic acid) in an ethanol/water solvent system is an economical, effective, and scalable method.^{[2][4]}
- Materials:
 - Crude 2-Chloro-1-(2-chlorophenoxy)-4-nitrobenzene (1.0 eq)
 - Iron powder (Fe, ~5 eq)
 - Ammonium Chloride (NH₄Cl, ~1.5 eq) or Acetic Acid (catalytic)
 - Ethanol (EtOH) and Water
- Procedure:
 - Combine the crude intermediate, ethanol, and water (e.g., 4:1 v/v) in a round-bottom flask.
 - Add iron powder and ammonium chloride.
 - Heat the suspension to reflux (approx. 80 °C) and stir vigorously. The reaction is often exothermic.
 - Monitor by TLC until the nitro-intermediate is fully consumed (typically 1-3 hours).
 - Cool the reaction to room temperature and filter through a pad of Celite to remove the iron salts, washing the pad with ethanol.
 - Concentrate the filtrate to remove most of the ethanol.
 - Add water and ethyl acetate. Basify the aqueous layer with a saturated sodium bicarbonate (NaHCO₃) solution to neutralize the acid.
 - Separate the layers and extract the aqueous phase with ethyl acetate (2x).

- Combine the organic layers, wash with brine, dry over Na_2SO_4 , and concentrate to yield the crude aniline product.

Purification Protocol: Flash Chromatography

- Rationale: Flash column chromatography is the standard method for purifying organic compounds of this nature, effectively separating the desired product from residual starting materials and byproducts based on polarity.
- Procedure:
 - Prepare a silica gel column.
 - Dissolve the crude product in a minimal amount of dichloromethane.
 - Load the sample onto the column.
 - Elute the column with a gradient of ethyl acetate in hexanes (e.g., starting from 5% ethyl acetate and gradually increasing to 20%). The less polar impurities will elute first.
 - Collect fractions and analyze by TLC to identify those containing the pure product.
 - Combine the pure fractions and evaporate the solvent to yield the final product as a solid.

Chapter 3: Analytical Characterization

Confirming the identity and purity of the synthesized compound is a critical, non-negotiable step in research. A combination of chromatographic and spectroscopic methods provides a self-validating system of analysis.

Analytical Workflow Diagram

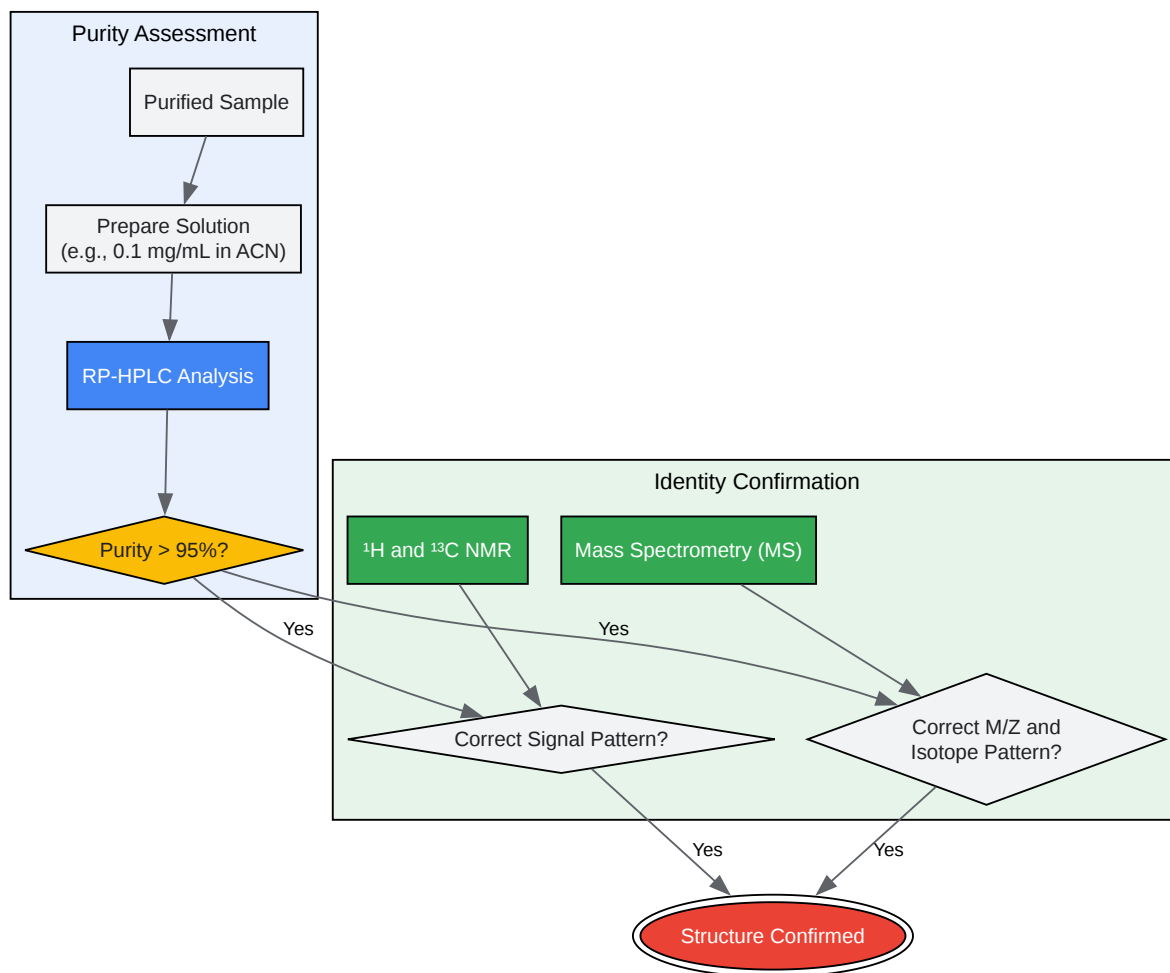

[Click to download full resolution via product page](#)

Caption: Integrated workflow for purity and identity verification.

Chromatographic Method: HPLC

High-Performance Liquid Chromatography (HPLC) is the gold standard for determining the purity of synthetic compounds.[5] A reverse-phase method is recommended.

- Rationale: A C18 column provides a nonpolar stationary phase that effectively separates moderately polar compounds like anilines. A gradient elution using acetonitrile and water allows for the efficient separation of the main compound from both more polar and less polar impurities. UV detection at 254 nm is suitable as the aromatic rings are strong chromophores.[5]

Parameter	Recommended Starting Condition
Column	C18, 4.6 x 150 mm, 5 µm particle size
Mobile Phase	A: Water (with 0.1% TFA or Formic Acid); B: Acetonitrile
Gradient	Start at 30% B, ramp to 95% B over 15 minutes, hold for 5 min
Flow Rate	1.0 mL/min
Detection	UV at 254 nm
Column Temp.	30 °C

Spectroscopic Methods

- Nuclear Magnetic Resonance (NMR) Spectroscopy: ^1H and ^{13}C NMR are essential for confirming the precise connectivity of the atoms.
 - ^1H NMR: Expect complex aromatic signals between ~6.5 and 7.5 ppm. The aniline $-\text{NH}_2$ protons will appear as a broad singlet, typically between 3.5 and 4.5 ppm, which is exchangeable with D_2O . The specific splitting patterns (doublets, triplets, doublet of doublets) of the seven aromatic protons will definitively confirm the substitution pattern.
 - ^{13}C NMR: Expect 12 distinct signals for the 12 aromatic carbons, with chemical shifts influenced by the attached substituents (Cl, O, NH_2).
- Mass Spectrometry (MS): MS confirms the molecular weight of the compound.

- Rationale: For this compound, high-resolution mass spectrometry (HRMS) should yield a molecular ion peak $[M+H]^+$ at m/z 254.0134.[2] A key diagnostic feature is the isotopic pattern caused by the two chlorine atoms (^{35}Cl and ^{37}Cl). This will result in a characteristic cluster of peaks: an $[M]^+$ peak, an $[M+2]^+$ peak (approx. 65% the intensity of M), and an $[M+4]^+$ peak (approx. 10% the intensity of M), providing unambiguous evidence for the presence of two chlorine atoms.

Chapter 4: Applications in Research and Drug Development

3-Chloro-4-(2-chlorophenoxy)aniline is not typically an end-product but rather a highly valuable building block or intermediate. Its structure is present in numerous complex molecules investigated for therapeutic purposes.

- Scaffold for Kinase Inhibitors: Many small-molecule kinase inhibitors, such as Lapatinib, utilize a substituted aniline core.[6] This compound provides a pre-formed diaryl ether scaffold that can be further functionalized at the amine group to build molecules that target the ATP-binding site of kinases involved in cancer cell signaling.[6]
- Precursor for Agrochemicals and Pharmaceuticals: The related isomer, 3-chloro-4-(4-chlorophenoxy)aniline, is a known intermediate in the synthesis of the anthelmintic drug Rafoxanide.[2] This highlights the utility of the chloro-phenoxy-aniline scaffold in developing agents against parasitic diseases.
- Materials Science: Substituted anilines are also used in the synthesis of dyes and specialized polymers, where the specific substituents can tune the material's color, thermal stability, and mechanical properties.[7]

Chapter 5: Safety, Handling, and Toxicology

While a specific safety data sheet for the 2-chloro isomer is not available, the GHS hazard classifications for the 4-chloro isomer provide an essential and reliable guide to its likely hazards.[1][8] All substituted anilines should be handled with care.

Hazard Identification

The compound is expected to be hazardous based on data from close structural analogs.[1]

Hazard Class	GHS Classification	Statement
Acute Oral Toxicity	Warning, H302	Harmful if swallowed
Skin Corrosion/Irritation	Warning, H315	Causes skin irritation
Eye Damage/Irritation	Warning, H319	Causes serious eye irritation
STOT Single Exposure	Warning, H335	May cause respiratory irritation

Handling and Personal Protective Equipment (PPE)

- Engineering Controls: Always handle this compound in a certified chemical fume hood to avoid inhalation of dust or vapors.
- Personal Protective Equipment:
 - Eye/Face Protection: Wear chemical safety goggles or a face shield.
 - Hand Protection: Wear nitrile or other chemically resistant gloves.
 - Skin and Body Protection: Wear a standard laboratory coat. Ensure no skin is exposed.
 - Respiratory Protection: For weighing or handling large quantities, a NIOSH-approved N95 (or better) particulate respirator is recommended.

Storage and Disposal

- Storage: Store in a tightly sealed container in a cool, dry, and well-ventilated area away from incompatible materials such as strong oxidizing agents.
- Disposal: Dispose of waste material and contaminated packaging in accordance with all local, state, and federal regulations. Contact a licensed professional waste disposal service. [\[8\]](#)

References

- PubChem. (n.d.). 3-Chloro-4-(4-chlorophenoxy)aniline. National Center for Biotechnology Information. Retrieved from [\[Link\]](#)

- National Center for Biotechnology Information. (2023). A simple and efficient synthesis of N-[3-chloro-4-(4-chlorophenoxy)-phenyl]-2-hydroxy-3,5-diiodobenzamide, rafoxanide. *Molécules* (Basel, Switzerland), 28(10), 4059. Retrieved from [\[Link\]](#)
- Acta Crystallographica Section E. (n.d.). 3-Chloro-4-(4-chlorophenoxy)-N-[(Z)-(5-nitrothiophen-2-yl)methylidene]aniline. Retrieved from [\[Link\]](#)
- Google Patents. (n.d.). CN106631715A - Preparation method of 3-chloro-4-(3-fluorobenzyloxy) aniline.
- Chemsrvc. (n.d.). MSDS of 3-CHLORO-4-(4-CHLOROPHENOXY)ANILINE. Retrieved from [\[Link\]](#)
- Carl ROTH. (2025). Safety Data Sheet: 3-Chloroaniline. Retrieved from [\[Link\]](#)
- Global Substance Registration System. (n.d.). 3-CHLORO-4-(4-CHLOROPHENOXY)ANILINE. Retrieved from [\[Link\]](#)
- Semantic Scholar. (n.d.). Practical Synthesis of 3-Chloro-4-(3-fluorobenzyloxy) aniline. Retrieved from [\[Link\]](#)
- Lead Sciences. (n.d.). **3-Chloro-4-(2-chlorophenoxy)aniline**. Retrieved from [\[Link\]](#)
- Organic Chemistry Portal. (n.d.). Diaryl ether synthesis by etherification (arylation). Retrieved from [\[Link\]](#)
- ResearchGate. (2025). An Improved Analytical Method, Based on HPLC with Electrochemical Detection, for Monitoring Exposure to 3-Chloro-4-fluoroaniline. Retrieved from [\[Link\]](#)
- Royal Society of Chemistry. (2024). Chapter 4: Synthetic Methods for Diaryl Ether Preparation Using Arylating Reagents. Retrieved from [\[Link\]](#)
- Google Patents. (n.d.). US4288386A - Ullmann reaction for the synthesis of diaryl ethers.

Need Custom Synthesis?

BenchChem offers custom synthesis for rare earth carbides and specific isotopic labeling.

Email: info@benchchem.com or [Request Quote Online](#).

Sources

- [1. 3-Chloro-4-\(4-chlorophenoxy\)aniline | C12H9Cl2NO | CID 90644 - PubChem \[pubchem.ncbi.nlm.nih.gov\]](#)
- [2. A simple and efficient synthesis of N-\[3-chloro-4-\(4-chlorophenoxy\)-phenyl\]-2-hydroxy-3,5-diodobenzamide, rafoxanide - PMC \[pmc.ncbi.nlm.nih.gov\]](#)
- [3. semanticscholar.org \[semanticscholar.org\]](#)
- [4. 3-CHLORO-4-\(3-CHLOROPHENOXY\)ANILINE synthesis - chemicalbook \[chemicalbook.com\]](#)
- [5. pdf.benchchem.com \[pdf.benchchem.com\]](#)
- [6. CN106631715A - Preparation method of 3-chloro-4-\(3-fluorobenzyloxy\) aniline - Google Patents \[patents.google.com\]](#)
- [7. Buy 3-Chloro-4-\(4-chlorophenoxy\)aniline | 24900-79-6 \[smolecule.com\]](#)
- [8. capotchem.cn \[capotchem.cn\]](#)
- To cite this document: BenchChem. [3-Chloro-4-(2-chlorophenoxy)aniline chemical structure]. BenchChem, [2026]. [Online PDF]. Available at: [\[https://www.benchchem.com/product/b1330836/docs#3-chloro-4-2-chlorophenoxy-aniline-chemical-structure\]](https://www.benchchem.com/product/b1330836/docs#3-chloro-4-2-chlorophenoxy-aniline-chemical-structure)

Disclaimer & Data Validity:

The information provided in this document is for Research Use Only (RUO) and is strictly not intended for diagnostic or therapeutic procedures. While BenchChem strives to provide accurate protocols, we make no warranties, express or implied, regarding the fitness of this product for every specific experimental setup.

Technical Support: The protocols provided are for reference purposes. Unsure if this reagent suits your experiment?

Need Industrial/Bulk Grade? [Request Custom Synthesis Quote](#)

BenchChem

Our mission is to be the trusted global source of essential and advanced chemicals, empowering scientists and researchers to drive progress in science and industry.

Contact

Address: 3281 E Guasti Rd
Ontario, CA 91761, United States
Phone: (601) 213-4426
Email: info@benchchem.com

[Contact our Ph.D. Support Team for a compatibility check](#)