

# Technical Support Center: Enhancing Resolution in Chromatographic Separation of MX Isomers

**Author:** BenchChem Technical Support Team. **Date:** January 2026

## Compound of Interest

Compound Name: 3-Chloro-4-(dichloromethyl)-5-hydroxy-2(5H)-furanone

Cat. No.: B133307

[Get Quote](#)

Welcome to the technical support center dedicated to resolving one of the most common challenges in analytical chemistry: the chromatographic separation of MX isomers. This guide is designed for researchers, scientists, and drug development professionals who encounter co-eluting or poorly resolved isomeric compounds. As your Senior Application Scientist, my goal is to provide not just procedural steps, but the underlying chromatographic principles to empower you to make informed decisions in your method development and troubleshooting endeavors.

Isomers, by their nature, possess identical mass and often very similar physicochemical properties, making their separation a non-trivial task. Whether you are dealing with positional isomers (e.g., ortho-, meta-, para-), geometric isomers (cis/trans), or enantiomers, achieving baseline resolution is critical for accurate identification and quantification. This guide provides a structured approach to troubleshooting and enhancing the resolution of your MX isomers.

## Part 1: Core Principles - Understanding the Resolution Equation

Before diving into troubleshooting, it is crucial to understand the fundamental equation that governs chromatographic resolution ( $R_s$ ). All our efforts to improve separation are aimed at manipulating the terms in this equation:

$$R_s = (\sqrt{N} / 4) * (\alpha - 1 / \alpha) * (k / k + 1)$$

Where:

- N (Efficiency): Represents the column's ability to produce narrow peaks. It is a function of column length and particle size.[\[1\]](#)[\[2\]](#)
- $\alpha$  (Selectivity): The most critical factor for isomer separation, it describes the relative retention of the two isomer peaks. If  $\alpha = 1$ , the peaks co-elute, and no separation is possible. [\[2\]](#)
- k (Retention Factor): Describes how long an analyte is retained on the column.[\[2\]](#)

Our troubleshooting will systematically address how to influence these three pillars of separation.

## The Interplay of Resolution Factors

The following diagram illustrates how experimental parameters connect to the core components of the resolution equation.

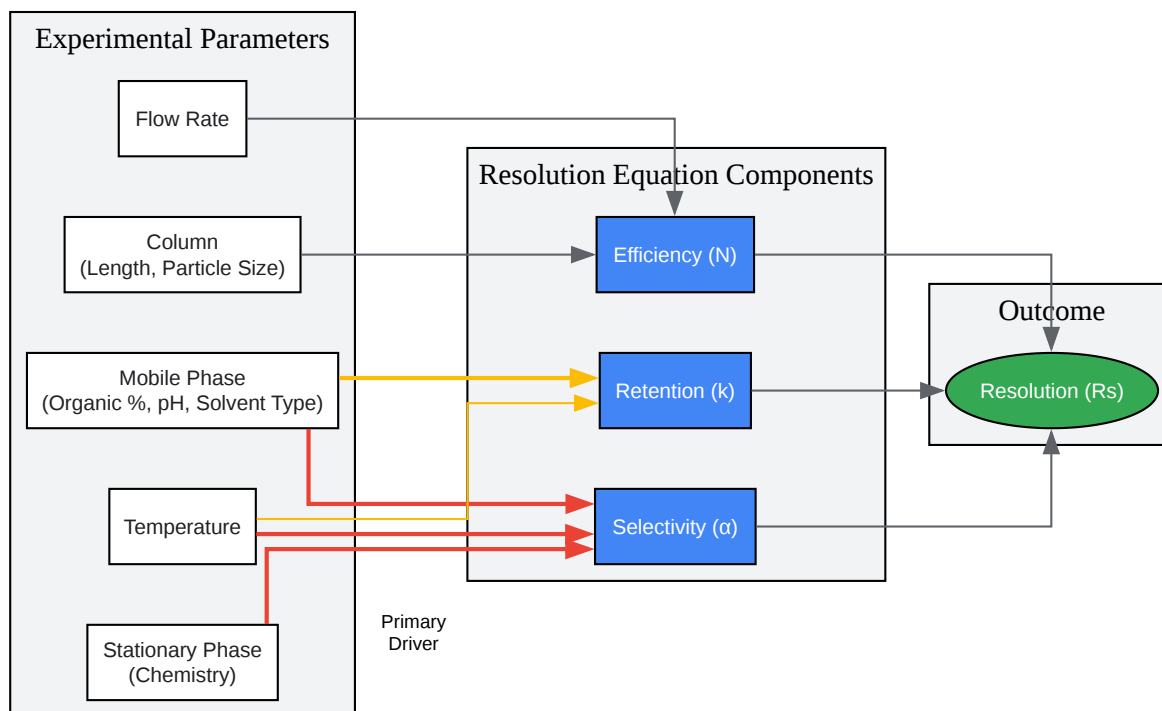

[Click to download full resolution via product page](#)

Caption: Relationship between experimental parameters and the resolution equation.

## Part 2: Troubleshooting Guide & FAQs

This section is structured in a question-and-answer format to directly address the issues you are likely encountering at the bench.

### Category 1: Stationary Phase (Column Chemistry)

The stationary phase is where the separation happens. Its chemistry dictates the types of interactions that can occur with your isomers.<sup>[3][4]</sup> If you are not getting separation, the most probable cause is that the stationary phase is not providing sufficient selectivity ( $\alpha$ ).

Question: My MX isomers are co-eluting on a standard C18 column. What is my next step?

Answer: A standard C18 column separates primarily based on hydrophobicity.[5] If your isomers have nearly identical hydrophobicity, a C18 column will not resolve them. The causality here is a lack of differential interaction. You must introduce alternative separation mechanisms.

Your immediate next step should be to switch to a column with a different stationary phase chemistry. The goal is to introduce interactions beyond simple hydrophobicity, such as  $\pi$ - $\pi$  interactions, dipole-dipole interactions, or shape selectivity.[6][7]

Recommended Actions:

- For Aromatic Positional Isomers (e.g., ortho-, meta-, para-): Switch to a Phenyl (e.g., Phenyl-Hexyl) or Pentafluorophenyl (PFP) column.[5][6][8]
  - Causality: These phases allow for  $\pi$ - $\pi$  interactions between the phenyl rings of the stationary phase and your aromatic isomers. Subtle differences in the electron density of the isomers, dictated by the substituent positions, will cause differential retention.[8]
- For Diastereomers or Cis/Trans Isomers: Consider columns that offer shape selectivity.
  - Causality: These isomers have different three-dimensional structures.
  - An Embedded Amide or carbamate phase can provide shape selectivity due to the spatial hindrance from the C=O group.[6]
  - A C8 column, having shorter carbon chains than C18, can sometimes offer better spatial selectivity as compounds can fit more easily between the bonded phases.[6]
- For Enantiomers (Chiral Isomers): Enantiomers have identical physical and chemical properties in an achiral environment and thus require a Chiral Stationary Phase (CSP) for separation.[9][10]
  - Causality: CSPs create a chiral environment where one enantiomer can interact more strongly with the stationary phase than its mirror image, leading to different retention times.[11]
  - Common CSPs include polysaccharide-based (e.g., cellulose, amylose) and macrocyclic glycopeptide phases.[12] The selection is often empirical, and screening several different

CSPs is a common and effective strategy.[12][13]

Stationary Phase	Primary Separation Mechanism(s)	Best Suited For...
C18 (Octadecylsilane)	Hydrophobic Interactions	General purpose, separation of homologs
Phenyl / PFP	Hydrophobic, $\pi$ - $\pi$ , Dipole-Dipole Interactions	Aromatic Positional Isomers[5][6]
Embedded Amide	Hydrophobic, Hydrogen Bonding, Shape Selectivity	Diastereomers, Polar Compounds[6]
Chiral (e.g., Polysaccharide)	Enantioselective Interactions (H-bonding, $\pi$ - $\pi$ , steric inclusion)	Enantiomers[10][12]

## Category 2: Mobile Phase Composition

The mobile phase composition is the most flexible tool for optimizing selectivity ( $\alpha$ ) and retention (k).[14][15] Small changes can lead to significant shifts in peak elution order and resolution.

Question: I see some separation, but the resolution is poor ( $R_s < 1.5$ ). How can I improve it by changing the mobile phase?

Answer: Poor resolution, where you see peak shoulders or significant overlap, indicates that the selectivity ( $\alpha$ ) is close to 1. Your goal is to increase the difference in how the two isomers interact with the system, and the mobile phase is a powerful tool to do so.

Recommended Actions:

- Change the Organic Modifier: This is the simplest and often most effective first step.
  - Causality: Different organic solvents have different properties (e.g., polarity, viscosity, proton-donating/accepting ability). Switching from acetonitrile (ACN) to methanol (MeOH), or vice versa, can alter the interactions between your isomers and the stationary phase,

often changing selectivity.[1] ACN is generally a stronger solvent in reversed-phase, while MeOH can offer different hydrogen-bonding capabilities.

- Adjust Mobile Phase pH (for ionizable isomers): If your MX isomers contain acidic or basic functional groups, pH is a critical parameter.
  - Causality: Changing the pH of the mobile phase can alter the ionization state of an analyte.[1][7] A neutral compound behaves very differently from its ionized counterpart. If your isomers have slightly different pKa values, adjusting the mobile phase pH to be near their pKa can dramatically increase selectivity as their ionization states will differ.
- Modify Buffer Concentration: For ionizable compounds, the buffer concentration can also impact peak shape and retention.
  - Causality: In HILIC, higher buffer concentrations can decrease retention by weakening electrostatic interactions.[16] In reversed-phase, it can influence secondary interactions and peak shape.
- Isocratic vs. Gradient Elution: If you are using a steep gradient, your peaks may not have enough time to separate.
  - Causality: A shallower gradient or switching to an isocratic hold (running with a constant mobile phase composition) gives the isomers more time to interact with the stationary phase, which can improve resolution for closely eluting peaks.[17]

### Category 3: Temperature

Temperature is an often-underutilized but powerful parameter for optimizing selectivity, especially for ionizable compounds.[18][19][20]

Question: I've tried changing my mobile phase, but the resolution is still not ideal. Can temperature help?

Answer: Yes, absolutely. Changing the column temperature affects the thermodynamics of the partitioning process between the mobile and stationary phases.

Recommended Actions:

- Systematically Vary the Temperature: Explore a range of temperatures (e.g., 25°C, 35°C, 45°C, 55°C).
  - Causality: An increase in temperature generally decreases retention time as it reduces mobile phase viscosity and increases analyte solubility.[21] However, the key benefit is its effect on selectivity. The retention of different compounds can change at different rates with temperature. For some isomer pairs, increasing the temperature might improve resolution; for others, it might worsen it.[19][21] This differential change is what you are trying to exploit.
  - Practical Insight: Temperature can be particularly effective for compounds that can exist in different conformational states, as temperature can alter the equilibrium between these states.[22] For ionizable compounds, temperature changes can affect mobile phase pH and analyte pKa, leading to significant selectivity changes.[18]

Parameter Change	Expected Primary Effect	Causality / Rationale
Increase Temperature	↓ Retention, Δ Selectivity	Reduces mobile phase viscosity, alters partitioning thermodynamics. Can be highly effective for ionizable compounds or those with conformational flexibility.[18][22]
Decrease Temperature	↑ Retention, Δ Selectivity	Increases mobile phase viscosity, may enhance subtle intermolecular interactions, leading to better separation.[23]

## Part 3: Systematic Troubleshooting Workflow

When faced with a separation challenge, a systematic approach is more effective than random changes. The following workflow provides a logical path to improving the resolution of your MX isomers.

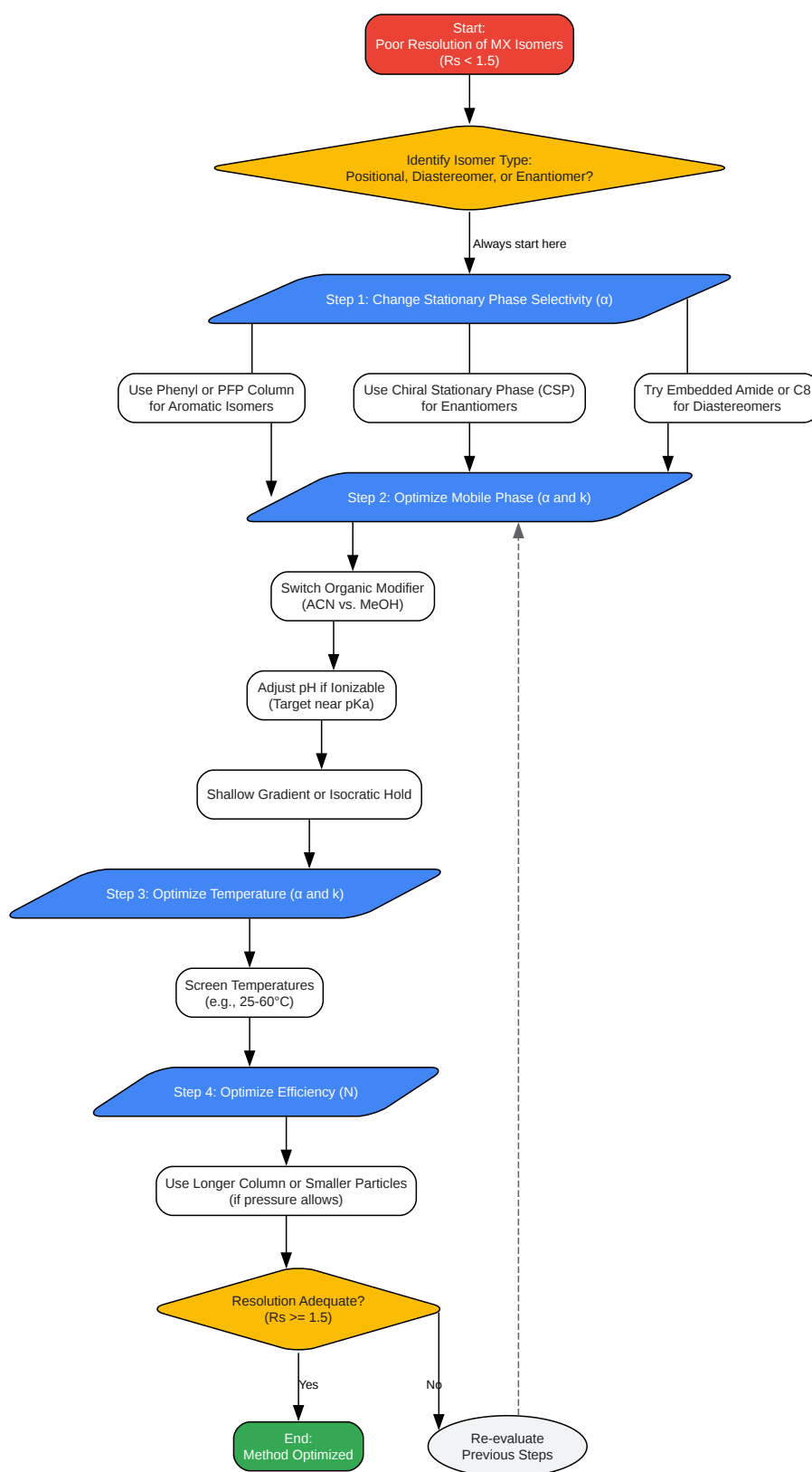

[Click to download full resolution via product page](#)

Caption: Systematic troubleshooting workflow for poor resolution of MX isomers.

## Part 4: Experimental Protocols

Here are detailed protocols for the most common optimization strategies.

### Protocol 1: Systematic Screening of Stationary Phases for Positional MX Isomer Separation

Objective: To identify a stationary phase that provides the best selectivity ( $\alpha$ ) for a set of aromatic positional isomers.

Materials:

- HPLC/UHPLC system with column switching valve (recommended) or manual column installation capability.
- Columns:
  - Standard C18 (as baseline)
  - Phenyl-Hexyl
  - Pentafluorophenyl (PFP)
- Isomer standard mix at a known concentration (e.g., 10  $\mu\text{g}/\text{mL}$ ).
- Mobile Phases: A) Water with 0.1% Formic Acid, B) Acetonitrile with 0.1% Formic Acid.

Procedure:

- Initial Gradient: Develop a generic, fast gradient to elute all isomers. For example: 5% B to 95% B over 10 minutes.
- Install C18 Column: Equilibrate the C18 column with the initial mobile phase conditions for 5-10 column volumes.
- Inject Standard: Inject the isomer standard mix and record the chromatogram.

- Calculate Initial Resolution: Note the retention times and calculate the resolution ( $R_s$ ) for the critical pair (the two most poorly separated isomers).
- Install Phenyl-Hexyl Column: Replace the C18 with the Phenyl-Hexyl column.
- Equilibrate and Inject: Repeat steps 2 and 3. Note any changes in elution order and resolution.
- Install PFP Column: Replace the Phenyl-Hexyl with the PFP column.
- Equilibrate and Inject: Repeat steps 2 and 3.
- Data Analysis: Compare the chromatograms from all three columns. The column providing the highest resolution for the critical pair is the best candidate for further method optimization. The causality for any observed improvement is the introduction of alternative retention mechanisms like  $\pi$ - $\pi$  interactions.<sup>[6][8]</sup>

## Protocol 2: Mobile Phase Optimization for Enhancing Selectivity ( $\alpha$ )

Objective: To fine-tune the mobile phase to maximize the resolution of two closely eluting isomers on a selected column.

Materials:

- HPLC/UHPLC system with the best column identified in Protocol 1.
- Isomer standard mix.
- Mobile Phase Solvents:
  - Solvent A1: Water + 0.1% Formic Acid
  - Solvent A2: pH 7.0 Phosphate Buffer (if analytes have pKa in this range)
  - Solvent B1: Acetonitrile
  - Solvent B2: Methanol

## Procedure:

- Establish Baseline: Using the best column from Protocol 1, run your current method (e.g., Water/ACN gradient) and record the resolution of the critical pair.
- Solvent Type Screening:
  - Replace Acetonitrile (B1) with Methanol (B2).
  - Adjust the gradient profile to account for methanol's different solvent strength (a gradient of 5-95% ACN might correspond to a 15-100% MeOH gradient).
  - Run the standard and compare the resolution ( $R_s$ ) and elution order to the baseline. A change in elution order is a strong indicator of a change in the dominant separation mechanism.
- pH Screening (if applicable):
  - If your isomers are ionizable, prepare a mobile phase with a different pH (e.g., switch from acidic A1 to neutral A2).
  - Equilibrate the column thoroughly with the new mobile phase.
  - Inject the standard and observe the change in retention and resolution. A significant shift indicates that you are successfully manipulating the analyte's charge state to improve separation.<sup>[7]</sup>
- Gradient Optimization:
  - Once the best solvent/pH combination is found, optimize the gradient.
  - If peaks are eluting too close together, make the gradient shallower in the region where the isomers elute. For example, if they elute at 40% B, change the gradient from "5-95% B in 10 min" to "30-50% B in 15 min". This increases the retention factor ( $k$ ) and gives the column more time to perform the separation.<sup>[17]</sup>
- Final Assessment: The combination of column, solvent type, pH, and gradient that yields a resolution ( $R_s$ ) of  $\geq 1.5$  is considered a robust and validated starting point.

## References

- A Strategy for Developing HPLC Methods for Chiral Drugs.
- How Does Temperature Affect Selectivity?
- Temperature selectivity in reversed-phase high performance liquid chromatography.
- Chiral HPLC Method Development. I.B.S. Analytical.
- Temperature selectivity in reversed-phase high performance liquid chromatography.
- How Does Temperature Affect Selectivity?
- Temperature Selectivity Effects in Reversed-Phase Liquid Chromatography Due to Conformation Differences Between Helical and Non-Helical Peptides. PubMed.
- Strategies for Chiral HPLC Method Development. Sigma-Aldrich.
- HPLC Technical Tip: Chiral Method Development. Phenomenex.
- Types of Chemical Isomers and Recommended HPLC Columns for Effective Separation.
- Getting Started with Chiral Method Development. Regis Technologies.
- [Reader Insight] A Guide to Selective Columns for Isomer Separation.
- Technical Support Center: Optimizing HPLC Separation.
- HPLC Columns & LC Columns | Types, How to Choose, Compare. GL Sciences.
- Choosing the Correct Column for Chromatographic Selectivity.
- Troubleshooting poor peak resolution in HPLC of aniline isomers. Benchchem.
- How To Improve Resolution In HPLC: 5 Simple Tips. PharmaGuru.
- Positional Isomer Separation Method Suggestions using HPLC or LCMS. MicroSolv.
- Optimization Strategies for HPLC Enantioseparation of Racemic Drugs Using Polysaccharides and Macrocyclic Glycopeptide Antibiotic Chiral Stationary Phase.
- Stationary phase | Chromatography.
- HPLC and UHPLC Column Selection Guide. Sigma-Aldrich.
- Solving Common Errors in HPLC. Omega Scientific.
- Stationary Phase Selectivity: The Chemistry Behind the Separation.
- Troubleshooting Poor Peak Shape and Resolution in HPLC. YouTube.
- How To Improve Resolution In Liquid Chromatography.
- Recent Developments of Liquid Chromatography Stationary Phases for Compound Separation: From Proteins to Small Organic Compounds. PMC - NIH.
- Mobile Phase Optimization: A Critical Factor in HPLC. Phenomenex.
- What is the function of the stationary phase?
- What are the Reasons for Resolution Failure in HPLC?
- Chromatography: Principle, Types, Steps, Uses, Diagram. Microbe Notes.
- Methods for Changing Peak Resolution in HPLC. Chrom Tech, Inc.
- Resolution of triacylglycerol positional isomers by reversed-phase high-performance liquid chromatography.

- Trouble resolving isomers.
- Crucial Role of Mobile Phase Composition in Chrom
- Effects of mobile phase composition on the reversed-phase separation of dipeptides and tripeptides with cyclodextrin-bonded-phase columns. PubMed.
- Real Solutions to Improve Your HPLC Peak Resolution. AnalyteGuru.
- Impact of Mobile Phase Composition on Separation Selectivity of Labeled Dextran Ladder in Hydrophilic Interaction Liquid Chrom
- Reverse-phase high performance liquid chromatography separation of positional isomers on the MIL-53(Fe) packed column. The Royal Society of Chemistry.

### Need Custom Synthesis?

BenchChem offers custom synthesis for rare earth carbides and specific isotopic labeling.

Email: [info@benchchem.com](mailto:info@benchchem.com) or [Request Quote Online](#).

## Sources

- 1. pharmaguru.co [pharmaguru.co]
- 2. chromtech.com [chromtech.com]
- 3. Stationary phase | Chromatography | Britannica [britannica.com]
- 4. reddit.com [reddit.com]
- 5. glsciencesinc.com [glsciencesinc.com]
- 6. welch-us.com [welch-us.com]
- 7. pdf.benchchem.com [pdf.benchchem.com]
- 8. Positional Isomer Separation Method Suggestions using HPLC or LCMS - Tips & Suggestions [mtc-usa.com]
- 9. hplc.today [hplc.today]
- 10. HPLC Technical Tip: Chiral Method Development | Phenomenex [phenomenex.com]
- 11. Getting Started with Chiral Method Development - Regis Technologies [registech.com]
- 12. chromatographyonline.com [chromatographyonline.com]
- 13. sigmaaldrich.com [sigmaaldrich.com]
- 14. Mobile Phase Optimization: A Critical Factor in HPLC [phenomenex.com]

- 15. longdom.org [longdom.org]
- 16. Impact of Mobile Phase Composition on Separation Selectivity of Labeled Dextran Ladder in Hydrophilic Interaction Liquid Chromatography - PMC [pmc.ncbi.nlm.nih.gov]
- 17. Trouble resolving isomers - Chromatography Forum [chromforum.org]
- 18. chromatographyonline.com [chromatographyonline.com]
- 19. Temperature selectivity in reversed-phase high performance liquid chromatography - PubMed [pubmed.ncbi.nlm.nih.gov]
- 20. chromatographyonline.com [chromatographyonline.com]
- 21. researchgate.net [researchgate.net]
- 22. Temperature selectivity effects in reversed-phase liquid chromatography due to conformation differences between helical and non-helical peptides - PubMed [pubmed.ncbi.nlm.nih.gov]
- 23. Real Solutions to Improve Your HPLC Peak Resolution - AnalyteGuru [thermofisher.com]
- To cite this document: BenchChem. [Technical Support Center: Enhancing Resolution in Chromatographic Separation of MX Isomers]. BenchChem, [2026]. [Online PDF]. Available at: [https://www.benchchem.com/product/b133307#enhancing-resolution-in-chromatographic-separation-of-mx-isomers]

---

### Disclaimer & Data Validity:

The information provided in this document is for Research Use Only (RUO) and is strictly not intended for diagnostic or therapeutic procedures. While BenchChem strives to provide accurate protocols, we make no warranties, express or implied, regarding the fitness of this product for every specific experimental setup.

**Technical Support:** The protocols provided are for reference purposes. Unsure if this reagent suits your experiment? [[Contact our Ph.D. Support Team for a compatibility check](#)]

**Need Industrial/Bulk Grade?** [Request Custom Synthesis Quote](#)

# BenchChem

Our mission is to be the trusted global source of essential and advanced chemicals, empowering scientists and researchers to drive progress in science and industry.

## Contact

Address: 3281 E Guasti Rd

Ontario, CA 91761, United States

Phone: (601) 213-4426

Email: [info@benchchem.com](mailto:info@benchchem.com)