

cyclic voltammetry of selenophene-based polymers

Author: BenchChem Technical Support Team. **Date:** May 2026

Compound of Interest

Compound Name: 2-Selenophenecarboxaldehyde

CAS No.: 25109-26-6

Cat. No.: B1329841

[Get Quote](#)

An In-Depth Comparative Guide to the Cyclic Voltammetry of Selenophene-Based Polymers

Authored by a Senior Application Scientist

This guide provides an in-depth analysis of the electrochemical behavior of selenophene-based polymers, primarily characterized through cyclic voltammetry (CV). It is designed for researchers, materials scientists, and professionals in drug development who are exploring advanced conjugated materials. We will delve into the fundamental electrochemical properties of these polymers, offering a direct comparison with their well-studied thiophene-based analogues, and provide detailed experimental protocols for accurate and reproducible characterization.

Introduction: The Significance of Selenophene in Conjugated Polymers

For decades, polythiophenes have been the benchmark material in the field of organic electronics. Their combination of environmental stability, synthetic versatility, and excellent charge-transport properties has made them ubiquitous. However, the quest for materials with

tailored electronic properties has driven researchers to explore analogues. Selenophene, the selenium-containing counterpart to thiophene, has emerged as a compelling building block for next-generation conjugated polymers.[1]

The substitution of sulfur with the larger, more polarizable selenium atom introduces several key changes to the polymer's electronic structure and solid-state packing.[2][3] These modifications often lead to a reduced bandgap, stronger intermolecular interactions, and altered charge carrier mobilities, making selenophene-containing polymers highly attractive for applications ranging from organic solar cells and field-effect transistors to advanced biosensors.[1][3][4]

Cyclic voltammetry (CV) is an indispensable technique for probing the redox behavior and electronic energy levels of these materials.[5] It provides a rapid and powerful method to determine fundamental parameters such as oxidation and reduction potentials, which are directly correlated to the Highest Occupied Molecular Orbital (HOMO) and Lowest Unoccupied Molecular Orbital (LUMO) energy levels.[6] This guide will compare the voltammetric signatures of selenophene-based polymers to their thiophene counterparts and provide the practical knowledge required to perform and interpret these critical measurements.

Comparative Electrochemistry: Selenophene vs. Thiophene Polymers

The replacement of sulfur with selenium in the heterocyclic ring has profound and predictable effects on the electrochemical properties of the resulting polymer. The larger atomic radius and greater polarizability of selenium compared to sulfur lead to enhanced inter-chain interactions and a more quinoidal character in the polymer backbone.[2][3] This directly influences the HOMO and LUMO energy levels.

Generally, the incorporation of selenophene into a conjugated polymer backbone results in:

- **Lowered HOMO and LUMO Energy Levels:** The increased polarizability of selenium stabilizes both the neutral and charged states of the polymer, leading to a decrease in the energy of both frontier orbitals.[2]
- **Reduced Electrochemical Bandgap:** The destabilization of the aromatic form and stabilization of the quinoidal form in polyselenophenes contribute to a smaller energy gap between the

HOMO and LUMO levels compared to analogous polythiophenes.[3]

- **Enhanced Redox Stability:** In some cases, copolymers incorporating selenophene have demonstrated excellent redox stability, which is crucial for the long-term operational lifetime of electronic devices like electrochromic windows and sensors.[7]

These differences are clearly observable in their cyclic voltammograms. Selenophene-based polymers typically exhibit both oxidation and reduction peaks at lower potentials than their thiophene analogues.

Data Presentation: Electrochemical Properties

The table below summarizes typical electrochemical data for poly(3-hexylselenophene) (P3HS) and its thiophene counterpart, poly(3-hexylthiophene) (P3HT), as determined by cyclic voltammetry. These values are crucial for designing device architectures and predicting material performance.

Polymer	Oxidation Onset (E _{ox} , V vs. Fc/Fc ⁺)	Reduction Onset (E _{red} , V vs. Fc/Fc ⁺)	HOMO Level (eV) ¹	LUMO Level (eV) ¹	Electrochemical Bandgap (E _g , eV)
Poly(3-hexylthiophene) (P3HT)	~-0.25	~-2.10	~-5.05	~-2.70	~-2.35
Poly(3-hexylselenophene) (P3HS)	~-0.15	~-1.95	~-4.95	~-2.85	~-2.10

¹HOMO and LUMO levels are estimated from the onset potentials using the empirical formula: $E_{\text{HOMO}} = -e(E_{\text{ox,onset}} + 4.8) \text{ eV}$ and $E_{\text{LUMO}} = -e(E_{\text{red,onset}} + 4.8) \text{ eV}$, where the potential of the Fc/Fc⁺ redox couple is assumed to be -4.8 eV relative to the vacuum level.

Experimental Protocol: A Guide to Performing Cyclic Voltammetry

Achieving reliable and reproducible CV data requires careful attention to experimental detail. This protocol outlines a self-validating system for characterizing a selenophene-based polymer film.

Core Causality in Experimental Design

- **Three-Electrode System:** Using a three-electrode setup is non-negotiable.[8] The reference electrode provides a stable potential against which the working electrode's potential is controlled, while the counter electrode serves to pass the current, preventing the reference electrode from being polarized. This separation of functions is key to accurate potential measurement.
- **Inert Atmosphere:** Dissolved oxygen is electroactive and its reduction can produce interfering peaks in the voltammogram, obscuring the true redox behavior of the polymer. Therefore, purging the electrolyte with an inert gas like argon or nitrogen is a critical step to ensure data integrity.
- **Internal Standard:** While external calibration against ferrocene is common, performing an in-situ measurement with ferrocene added to the electrolyte after the polymer scan provides a more accurate reference. This internally calibrates the potential axis, compensating for any minor drift or variations in the reference electrode potential.

Step-by-Step Methodology

1. **Working Electrode Preparation:** a. Prepare a dilute solution of the selenophene-based polymer (e.g., 1-5 mg/mL) in a suitable solvent like chloroform or chlorobenzene. b. Thoroughly clean the working electrode (e.g., glassy carbon or platinum button electrode) by polishing with alumina slurry, followed by sonication in deionized water and isopropanol. c. Dry the electrode under a stream of nitrogen. d. Deposit the polymer solution onto the electrode surface via drop-casting or spin-coating to form a thin, uniform film. e. Dry the film under vacuum to remove residual solvent. A uniform film is essential for consistent current response.

2. **Electrochemical Cell Assembly:** a. Place the polymer-coated working electrode, a platinum wire counter electrode, and an Ag/AgCl or Ag/Ag⁺ reference electrode into the electrochemical cell.[9] b. Add the electrolyte solution, typically 0.1 M of an inert salt like tetrabutylammonium hexafluorophosphate (TBAPF₆) in anhydrous, de-gassed acetonitrile. Ensure the electrodes are sufficiently immersed. c. Seal the cell and begin purging with high-purity argon or nitrogen

for at least 15-20 minutes. Maintain a gentle inert gas blanket over the solution throughout the experiment.

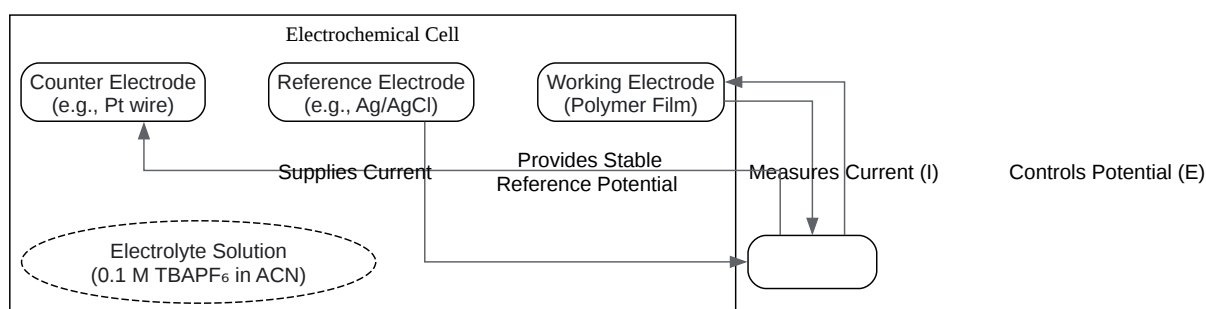

[Click to download full resolution via product page](#)

Caption: Diagram of a standard three-electrode setup for CV.

3. Data Acquisition: a. Connect the electrodes to a potentiostat.^[10] b. Set the experimental parameters. A typical scan for a conjugated polymer would be:

- Initial Potential: 0 V
 - Vertex 1 (Oxidation): +1.5 V
 - Vertex 2 (Reduction): -2.0 V
 - Final Potential: 0 V
 - Scan Rate: 50-100 mV/s
 - Number of Cycles: 3 (The first cycle may differ due to initial film conditioning; the 2nd and 3rd cycles are typically more representative).
- c. Run the experiment to record the cyclic voltammogram.

4. Data Interpretation and Analysis: a. After the initial scan, add a small amount of ferrocene to the cell and record its voltammogram. b. Determine the half-wave potential of the ferrocene/ferrocenium (Fc/Fc⁺) couple ($E_{1/2} = (E_{pa} + E_{pc})/2$). c. Correct all potentials in the polymer voltammogram by referencing them to the measured Fc/Fc⁺ potential. d. Identify the onset of oxidation ($E_{ox,onset}$) and reduction ($E_{red,onset}$) from the polymer's voltammogram.

These are the points where the current begins to deviate from the baseline. e. Calculate the HOMO and LUMO energy levels using the formulas provided in the table footnote.

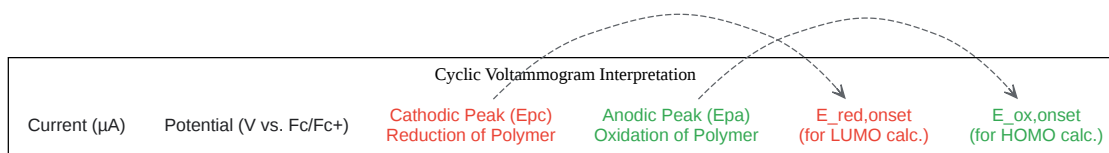

[Click to download full resolution via product page](#)

Caption: Key features of a typical polymer cyclic voltammogram.

Applications and Advanced Insights

The data derived from CV is not merely academic; it provides critical insights into a material's suitability for specific applications.

- **Organic Electrochemical Transistors (OECTs):** For OECTs, which rely on ion injection and removal to modulate conductivity, CV is used to assess the material's volumetric capacitance and electrochemical stability over repeated cycles.[2] Selenophene-based polymers have been shown to achieve remarkable volumetric capacitance and high electron mobility, making them state-of-the-art materials for n-type OECTs and biosensors.[11]
- **Supercapacitors:** In the context of energy storage, CV is used to evaluate the specific capacity of a polymer electrode. Selenophene-containing polymers have been investigated as potential supercapacitor materials due to their distinct redox behavior.[12]
- **Electrochromic Devices:** The reversibility of the redox peaks, the stability over many cycles, and the potential at which oxidation/reduction occurs are all determined by CV. These parameters are directly related to the switching speed, durability, and color-contrast of an electrochromic device. Copolymers of selenophene and thiophene have shown enhanced redox stability and favorable optical contrast compared to their parent homopolymers.[7]

Conclusion and Future Outlook

Cyclic voltammetry is a cornerstone technique for the characterization of novel conjugated materials. As this guide has demonstrated, the substitution of thiophene with selenophene imparts distinct and often advantageous electrochemical properties, including lower redox potentials and narrower electrochemical bandgaps. These features, readily quantified by CV, are what make selenophene-based polymers prime candidates for high-performance electronic and electrochemical devices.

The continued exploration of selenophene-containing copolymers and the fine-tuning of their properties through synthetic design will undoubtedly lead to further advancements. A thorough and rigorous understanding of their electrochemical behavior, grounded in the principles and protocols outlined here, is essential for any researcher aiming to innovate in this exciting field.

References

- Enhanced redox stability and optical contrast of electrochromic copolymers from selenophene and 3-methylthiophene. (n.d.).
- A Preliminary Study of Cyclic Voltammetry of a Conducting Polymer. (n.d.).
- How to perform cyclic voltammetry of a polymer using a potentiostat (Quickstart guide). (2022, February 7). YouTube.
- Cyclic Voltammetry. Melville Laboratory for Polymer Synthesis - University of Cambridge. (n.d.).
- Effects of selenium incorporation on the performance of polythiophene based organic electrochemical transistors. (n.d.).
- Solid-State and Electrochemical Properties of Polyselenophene. (1987). *Journal of Applied Physics*, 62(1), 190-194.
- Selenophene-containing conjugated polymers for supercapacitor electrodes. (n.d.).
- Cyclic voltammetry experimental set-up. (n.d.).
- Cyclic Voltammetry Uses | How to Read a Voltammogram. (n.d.). Ossila.
- Cyclic Voltammetry Experiment. (n.d.). Gamry Instruments.
- Polyselenophenes. (n.d.).
- Selenophene Substitution Enabled High-Performance n-Type Polymeric Mixed Ionic-Electronic Conductors for Organic Electrochemical Transistors and Glucose Sensors. (2024).
- Cyclic Voltammetry: Interpretation of Simple Cyclic Voltammogram. (2022, November 20). YouTube.
- Conjugated polymers based on selenophene building blocks. (2022). KAUST Repository.
- Cyclic Voltammetry. (2023, August 29). Chemistry LibreTexts.

- Recent Advances in Selenophene-Based Materials for Organic Solar Cells. (n.d.). PMC.

Need Custom Synthesis?

BenchChem offers custom synthesis for rare earth carbides and specific isotopic labeling.

Email: info@benchchem.com or [Request Quote Online](#).

Sources

- 1. DSpace [repository.kaust.edu.sa]
- 2. csqs.xjtu.edu.cn [csqs.xjtu.edu.cn]
- 3. researchgate.net [researchgate.net]
- 4. Recent Advances in Selenophene-Based Materials for Organic Solar Cells - PMC [[pmc.ncbi.nlm.nih.gov](https://pubmed.ncbi.nlm.nih.gov/31111111/)]
- 5. chem.libretexts.org [chem.libretexts.org]
- 6. ossila.com [ossila.com]
- 7. researchgate.net [researchgate.net]
- 8. Cyclic Voltammetry | Melville Laboratory for Polymer Synthesis [melville.group.ch.cam.ac.uk]
- 9. researchgate.net [researchgate.net]
- 10. m.youtube.com [m.youtube.com]
- 11. Selenophene Substitution Enabled High-Performance n-Type Polymeric Mixed Ionic-Electronic Conductors for Organic Electrochemical Transistors and Glucose Sensors - PubMed [[pubmed.ncbi.nlm.nih.gov](https://pubmed.ncbi.nlm.nih.gov/31111111/)]
- 12. researchgate.net [researchgate.net]
- To cite this document: BenchChem. [cyclic voltammetry of selenophene-based polymers]. BenchChem, [2026]. [Online PDF]. Available at: [<https://www.benchchem.com/product/b1329841/docs#cyclic-voltammetry-of-selenophene-based-polymers>]

Disclaimer & Data Validity:

The information provided in this document is for Research Use Only (RUO) and is strictly not intended for diagnostic or therapeutic procedures. While BenchChem strives to provide accurate protocols, we make no warranties, express or implied, regarding the fitness of this product for every specific experimental setup.

Technical Support: The protocols provided are for reference purposes. Unsure if this reagent suits your experiment?

Need Industrial/Bulk Grade? [Request Custom Synthesis Quote](#)

BenchChem

Our mission is to be the trusted global source of essential and advanced chemicals, empowering scientists and researchers to drive progress in science and industry.

Contact

Address: 3281 E Guasti Rd
Ontario, CA 91761, United States
Phone: (601) 213-4426
Email: info@benchchem.com

[Contact our Ph.D. Support Team for a compatibility check](#)