

# PCB 134 vs. PCB 135: Isomer Structural & Functional Divergence

**Author:** BenchChem Technical Support Team. **Date:** April 2026

## Compound of Interest

Compound Name: 2,2',3,3',5,6-Hexachlorobiphenyl

CAS No.: 52704-70-8

Cat. No.: B1329219

[Get Quote](#)

## A Technical Guide for Analytical & Toxicological Applications

### Executive Summary

In the analysis of polychlorinated biphenyls (PCBs), the differentiation between hexachlorobiphenyl isomers PCB 134 and PCB 135 represents a critical challenge in high-resolution mass spectrometry and environmental toxicology. While both share the formula  $C_{12}H_4Cl_6$  and possess three ortho-chlorine substitutions (rendering them non-coplanar), they diverge fundamentally in their stereochemistry.

The definitive distinction lies in chirality:

- PCB 135 is axially chiral (atropisomerism) due to asymmetric substitution on both phenyl rings combined with a high rotational energy barrier.
- PCB 134 is achiral (prochiral) due to the presence of a plane of symmetry within its 2,3,5,6-substituted ring.

This structural difference dictates their behavior in gas chromatography (GC) separation and their metabolic fate in biological systems, where PCB 135 undergoes enantioselective biotransformation.

## Structural Anatomy & Stereochemistry

To understand the analytical separation and biological activity, we must first dissect the molecular geometry. Both congeners are "Ballschmiter & Zell" (BZ) hexachlorobiphenyls.

### IUPAC Nomenclature and Substitution

Congener	BZ Number	IUPAC Name	Chlorine Substitution Pattern	Ortho Cl Count
PCB 134	134	2,2',3,3',5,6-Hexachlorobiphenyl	Ring A: 2,3,5,6 (Tetra)Ring B: 2,3 (Di)	3 (2, 2', 6)
PCB 135	135	2,2',3,3',5,6'-Hexachlorobiphenyl	Ring A: 2,3,5 (Tri)Ring B: 2,3,6 (Tri)	3 (2, 2', 6')

## The Chirality Determinant

The "ortho-effect" in PCBs with 3 or 4 ortho-chlorines creates significant steric hindrance, locking the two phenyl rings in a non-planar conformation (approx. 90° twist). This prevents free rotation around the C1-C1' bond.

- Why PCB 135 is Chiral: Both rings in PCB 135 are asymmetrically substituted. Ring A is 2,3,5-substituted (asymmetric). Ring B is 2,3,6-substituted (asymmetric). Because the rotation is hindered and neither ring possesses a plane of symmetry perpendicular to the ring plane, the molecule exists as two non-superimposable mirror images (atropisomers).[1][2]
- Why PCB 134 is Achiral: Ring A of PCB 134 is 2,3,5,6-substituted. A plane of symmetry passes through the C1 and C4 axis of this ring. Even though the molecule is locked in a twisted conformation, this internal plane of symmetry renders the molecule superimposable on its mirror image. It is therefore achiral.

## Structural Visualization (DOT Diagram)

The following diagram illustrates the symmetry operations and substitution logic.

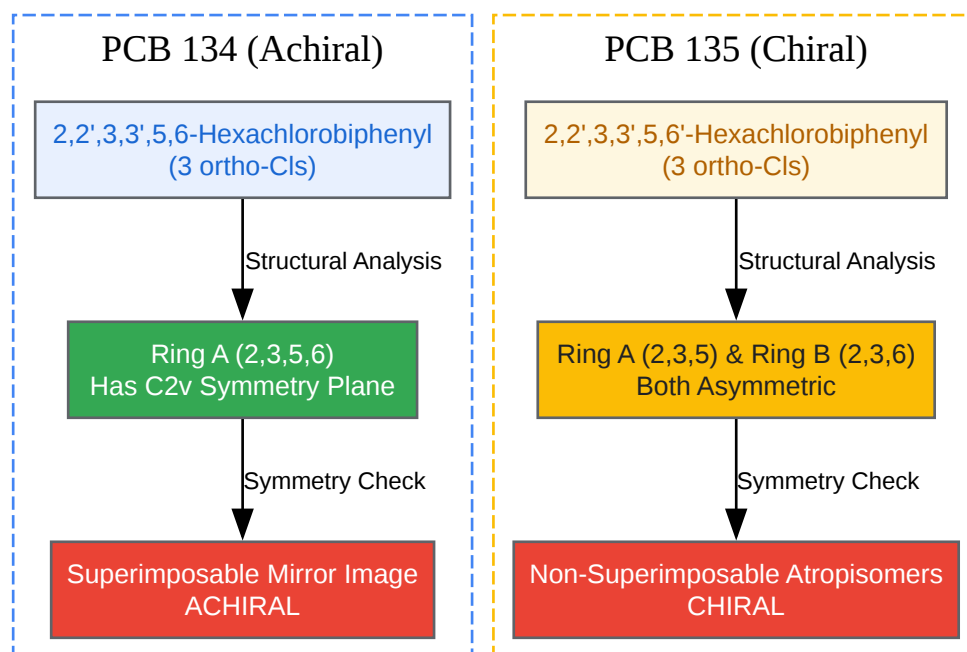

[Click to download full resolution via product page](#)

Caption: Structural logic determining the chirality of PCB 135 versus the achirality of PCB 134 based on ring substitution symmetry.

## Analytical Profiling: The Self-Validating Protocol

Distinguishing these isomers requires precise chromatographic conditions. Standard low-resolution GC methods may result in co-elution or misidentification.

## Chromatographic Separation Strategy

Column Selection:

- Standard 5% Phenyl (e.g., DB-5ms): PCB 134 and 135 elute very close to each other. PCB 134 typically elutes before PCB 135 due to slightly higher volatility associated with the symmetric tetra-substitution on one ring.

- High-Resolution Phase (e.g., HT-8 or DB-XLB): These phases are engineered for PCB congener specificity and provide baseline separation.
- Chiral Columns (e.g., Chirasil-Dex): Required only if quantifying the enantiomeric fraction (EF) of PCB 135. PCB 134 will elute as a single peak, while PCB 135 splits into two enantiomers.

## GC-MS/MS Methodology (MRM Mode)

To ensure data integrity, use Multiple Reaction Monitoring (MRM). While EI spectra are similar, retention time markers are mandatory.

Protocol Steps:

- Extraction: Soxhlet extraction (sediment) or Liquid-Liquid Extraction (plasma) using Hexane:Acetone (1:1).
- Cleanup: Acidified silica gel column (removes lipids) followed by Florisil fractionation.
- Instrument: Triple Quadrupole GC-MS/MS.
- Transitions:
  - Precursor Ion:  $m/z$  360 ( $M^+$ ) and 362 ( $M+2$ ).
  - Product Ion:  $m/z$  290 ( $M - Cl_2$ ).
  - Note: Both congeners have identical transitions. Retention Time (RT) locking using a reference standard (e.g., NIST SRM 2262) is the only validation method.

Data Table: Elution Characteristics (Relative)

Parameter	PCB 134	PCB 135
Elution Order (DB-5ms)	Elutes First	Elutes Second (approx. +0.2 min lag)
Chiral Column Behavior	Single Peak	Double Peak (Atropisomers)
Key Interference	Co-elutes with PCB 114 on some phases	Co-elutes with PCB 144 on some phases

## Toxicological & Biological Fate[4]

The structural difference (chiral vs. achiral) translates directly into biological fate, specifically regarding metabolism by Cytochrome P450 (CYP) enzymes.[3]

## Metabolism and Bioaccumulation

- PCB 134 (Achiral):
  - Metabolized primarily by CYP2B and CYP3A isoforms (Phenobarbital-type inducers).
  - Forms hydroxylated metabolites (OH-PCBs) such as 4-OH-PCB 134.
  - Since it is achiral, metabolism is purely a function of chemical kinetics, not stereoselectivity.
- PCB 135 (Chiral):
  - Subject to Enantioselective Metabolism.
  - CYP enzymes (e.g., CYP2B6 in humans) often preferentially metabolize one atropisomer over the other.
  - Result: Biological samples (blood, tissue) often show non-racemic mixtures of PCB 135 (Enantiomeric Fraction  $\neq$  0.5), serving as a "biological fingerprint" of metabolic processing.

## Toxicity Profile

Both congeners are Non-Dioxin-Like (NDL) due to the three ortho-chlorines preventing the planar conformation required for AhR binding.

- Mechanism: Neurotoxicity (via Ryanodine receptor sensitization) and Endocrine Disruption.
- Specific Risk: Chiral PCBs like 135 are of high interest in neurodevelopmental research because specific enantiomers may possess higher potency for neurotoxicity.

## Biological Pathway Diagram

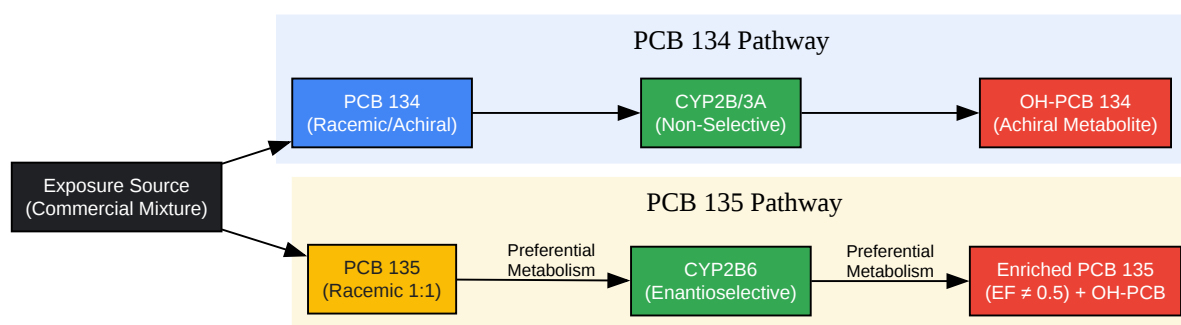

[Click to download full resolution via product page](#)

Caption: Differential metabolic pathways showing enantioselective processing of PCB 135 vs. non-selective processing of PCB 134.

## References

- Ballschmiter, K., & Zell, M. (1980). Analysis of polychlorinated biphenyls (PCB) by glass capillary gas chromatography.[4] *Fresenius' Zeitschrift für analytische Chemie*.
- Lehmler, H. J., et al. (2010). Chiral Polychlorinated Biphenyls: Absorption, Metabolism and Excretion. *Journal of Environmental Science and Health, Part C*.
- Kania-Korwel, I., & Lehmler, H. J. (2016). Microsomal Metabolism of Prochiral Polychlorinated Biphenyls Results in the Enantioselective Formation of Chiral Metabolites.[5] *Environmental Science & Technology*.[1]

- Wong, C. S., et al. (2001). Enantiomeric composition of chiral polychlorinated biphenyls in aquatic and riparian food webs. Environmental Science & Technology.[1]
- Frame, G. M. (1997). A collaborative study of 209 PCB congeners on 20 capillary gas chromatography columns.[4] Fresenius' Journal of Analytical Chemistry.

### Need Custom Synthesis?

BenchChem offers custom synthesis for rare earth carbides and specific isotopic labeling.

Email: [info@benchchem.com](mailto:info@benchchem.com) or [Request Quote Online](#).

## Sources

- [1. New insight into how long-banned chemicals \(PCBs\) unleash their toxicity inside the body | EurekAlert! \[eurekalert.org\]](#)
- [2. Distribution of Chiral PCBs in Selected Tissues in the Laboratory Rat - PMC \[pmc.ncbi.nlm.nih.gov\]](#)
- [3. open.clemson.edu \[open.clemson.edu\]](#)
- [4. accustandard.com \[accustandard.com\]](#)
- [5. Research Portal \[iro.uiowa.edu\]](#)
- To cite this document: BenchChem. [PCB 134 vs. PCB 135: Isomer Structural & Functional Divergence]. BenchChem, [2026]. [Online PDF]. Available at: [\[https://www.benchchem.com/product/b1329219/docs#pcb-134-vs-pcb-135-isomer-structural-functional-divergence\]](https://www.benchchem.com/product/b1329219/docs#pcb-134-vs-pcb-135-isomer-structural-functional-divergence)

---

### Disclaimer & Data Validity:

The information provided in this document is for Research Use Only (RUO) and is strictly not intended for diagnostic or therapeutic procedures. While BenchChem strives to provide accurate protocols, we make no warranties, express or implied, regarding the fitness of this product for every specific experimental setup.

**Technical Support:** The protocols provided are for reference purposes. Unsure if this reagent suits your experiment?

**Need Industrial/Bulk Grade?** [Request Custom Synthesis Quote](#)

## BenchChem

Our mission is to be the trusted global source of essential and advanced chemicals, empowering scientists and researchers to drive progress in science and industry.

### Contact

Address: 3281 E Guasti Rd  
Ontario, CA 91761, United States  
Phone: (601) 213-4426  
Email: [info@benchchem.com](mailto:info@benchchem.com)

[Contact our Ph.D. Support Team for a compatibility check](#)