

Application Note: High-Precision Synthesis and Photocatalytic Application of Bismuth Oxyfluoride (BiOF)

Author: BenchChem Technical Support Team. **Date:** April 2026

Compound of Interest

Compound Name: *Bismuth fluoride*

CAS No.: 7787-61-3

Cat. No.: B1329470

[Get Quote](#)

Executive Summary: The Internal Electric Field Advantage

Bismuth Oxyfluoride (BiOF) represents a class of Sillén-Aurivillius related oxyhalides defined by their unique layered tetragonal structure (

slabs interleaved with double fluoride

layers). Unlike isotropic photocatalysts (e.g.,

), BiOF possesses a strong Internal Electric Field (IEF) along the [001] direction. This IEF acts as a built-in driving force to separate photogenerated electrons and holes, significantly suppressing charge recombination—the primary bottleneck in photocatalytic efficiency.

This guide provides a rigorous, GLP-aligned protocol for synthesizing Oxygen-Deficient BiOF (

), where engineered oxygen vacancies (OVs) narrow the band gap for visible light absorption and serve as metastable sites for

activation.

Material Synthesis: Solvothermal Engineering of BiOF

To maximize catalytic activity, we utilize a solvothermal reduction method. Unlike aqueous hydrothermal synthesis, the use of ethylene glycol (EG) as a solvent acts as a mild reducing agent, intentionally introducing oxygen vacancies (OVs) into the lattice.

Reagents and Equipment

- Precursors:
 - (99.99%, Sigma),
 - (99.99%).
- Solvent: Ethylene Glycol (Anhydrous) / Ethanol (Absolute).
- Reactor: 50 mL Teflon-lined stainless steel autoclave.
- Calcination: Tubular furnace with
flow.

Step-by-Step Synthesis Protocol

- Precursor Dissolution:
 - Dissolve 2 mmol of
in 20 mL of Ethylene Glycol. Sonicate for 15 mins until a clear solution forms (Solution A).
 - Note: EG serves as both solvent and capping agent to control nanosheet morphology.
- Fluorination:
 - Dissolve 2 mmol of
in 10 mL deionized water.

- Add the solution dropwise to Solution A under vigorous magnetic stirring (500 rpm). A white precipitate will form immediately.
- Stir for 30 minutes to ensure homogeneity.
- Solvothermal Treatment:
 - Transfer the suspension to the Teflon-lined autoclave (fill factor ~60%).
 - Seal and heat at 160°C for 24 hours.
 - Causality: The temperature and pressure drive the crystallization of the tetragonal phase, while the EG environment promotes the formation of surface defects (OVs).
- Purification (Critical for Reproducibility):
 - Centrifuge the resulting white powder at 8000 rpm for 10 mins.
 - Wash 3x with Ethanol (to remove organic residues) and 3x with DI Water (to remove excess ions).
- Drying & Activation:
 - Dry at 60°C under vacuum overnight.
 - Optional: Anneal at 300°C in for 2 hours to improve crystallinity without oxidizing the vacancies.

Synthesis Workflow Diagram

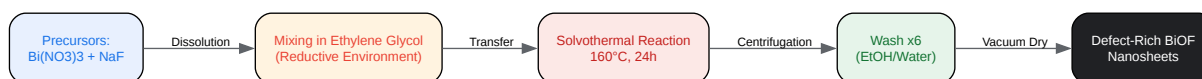

[Click to download full resolution via product page](#)

Caption: Optimized solvothermal workflow for creating oxygen-vacancy-rich BiOF nanosheets.

Characterization & Quality Control (QC)

Before application, the material must pass the following QC checks to ensure the presence of the IEF and Oxygen Vacancies.

Technique	Target Metric	Acceptance Criteria
XRD	Crystal Phase	Tetragonal Matlockite phase (JCPDS No. 73-1590). Sharp (001) peaks indicate good layered stacking.
XPS	Surface Defects	High-resolution O 1s spectrum must show a shoulder peak at ~531.5 eV (indicating Oxygen Vacancies), distinct from lattice oxygen (~530 eV).
UV-Vis DRS	Band Gap	Absorption edge redshifted from ~360nm (Pure BiOF) to ~420nm (Defect BiOF).
EPR	Vacancy Confirmation	Strong signal at $g = 2.002$ confirming unpaired electrons trapped in vacancies.

Application Protocol: Photocatalytic Water Splitting

BiOF typically has a valence band (VB) potential of ~3.5 eV and a conduction band (CB) of ~0.3 eV. While the VB is deep enough for water oxidation, the CB is often insufficient for

evolution without modification. Therefore, a Z-scheme heterojunction or sacrificial agent is required.

Experimental Setup

- Light Source: 300W Xenon Lamp (simulate solar spectrum) with 420nm cut-off filter (for visible light tests).

- Reactor: Top-irradiation Pyrex vessel connected to a closed gas circulation system.
- Detector: Online Gas Chromatograph (GC) with TCD detector (Ar carrier gas).

Protocol (Half-Reaction: Evolution)

- Catalyst Loading: Disperse 50 mg of BiOF powder in 100 mL DI water.
- Sacrificial Agent: Add 0.01 M
(electron scavenger).
 - Note:
captures electrons, allowing us to isolate the hole-driven oxidation kinetics ().
- Degassing: Evacuate the system for 30 mins to remove dissolved air (/).
- Irradiation: Turn on the Xe lamp. Maintain reactor temperature at 25°C using a cooling water jacket.
- Sampling: Auto-sample gas every 30 minutes for 4 hours.

Application Protocol: Photoreduction

This is the primary application for BiOF due to the high affinity of oxygen vacancies for molecules.

The "Self-Validating" Isotope Trace

To prove that the evolved carbon products (CO,
) originate from

and not organic contaminants,

isotope tracing is mandatory for high-impact validation.

Protocol

- System Prep: Use a gas-tight stainless steel reactor with a quartz window.
- Loading: Spread 20 mg of BiOF catalyst on a glass filter holder inside the reactor. Add 5 mL of DI water to the bottom of the reactor (vapor source) but do not submerge the catalyst (Solid-Gas phase reaction is preferred for BiOF).
- Purging: Purge with high-purity (99.999%) for 1 hour.
- Reaction: Seal the reactor (pressure ~1 atm). Irradiate for 4-6 hours.
- Analysis:
 - Gas Phase: Inject headspace gas into GC-FID/TCD.
 - Validation: Use GC-MS. If using , look for $m/z = 29$ (for) and $m/z = 17$ (for).

Mechanistic Insight: The IEF and Vacancy Synergy

The superior performance of BiOF stems from the synergy between the Internal Electric Field (IEF) and surface Oxygen Vacancies (OVs).

- Charge Separation: Upon excitation, the layers act as electron acceptors, while layers act as donors. The static IEF drives electrons toward the positive slab, physically separating them from holes.

- Activation:

adsorbs onto the Oxygen Vacancy.[1][2] The localized electron density at the vacancy weakens the C=O bond, lowering the activation energy for reduction.

Mechanism Diagram

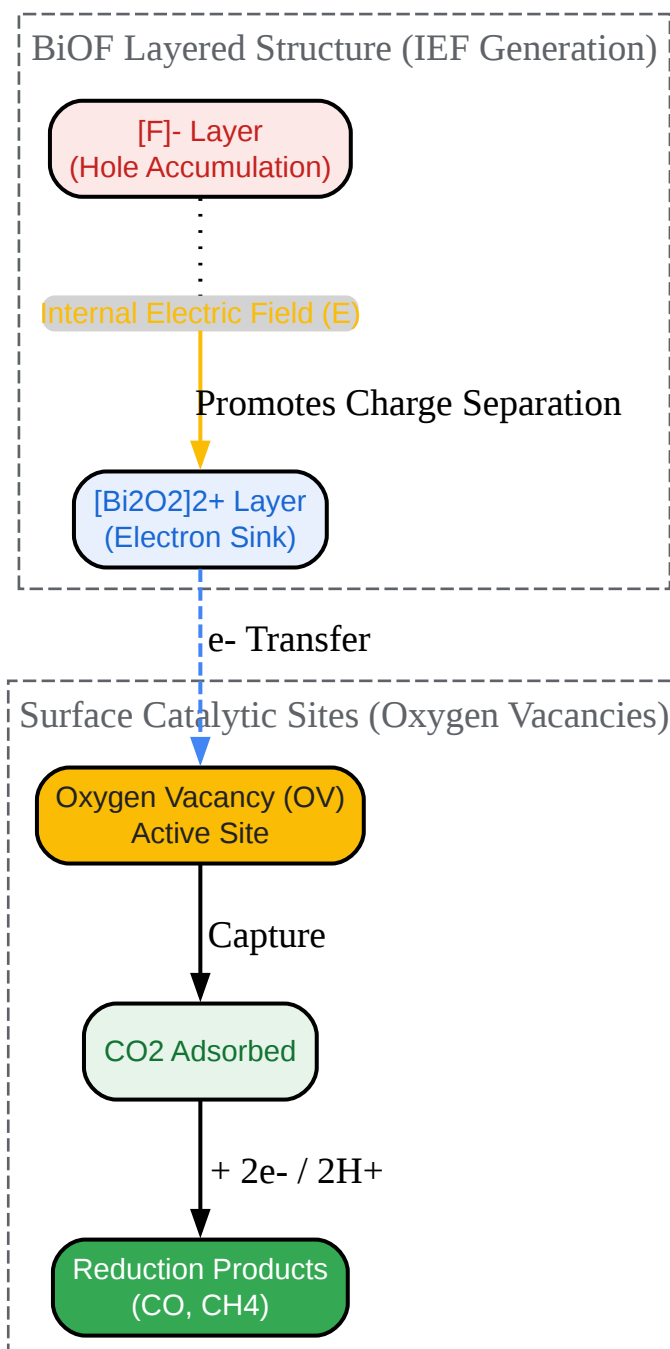

[Click to download full resolution via product page](#)

Caption: Mechanism illustrating the Internal Electric Field (IEF) driving electrons to surface vacancies for CO₂ activation.

Troubleshooting & Optimization

Issue	Probable Cause	Corrective Action
Low Activity	High recombination rate.	Check crystallinity (XRD). If peaks are broad, increase calcination temp to 300°C.
No Visible Light Activity	Band gap too wide (Pure BiOF).	Increase Ethylene Glycol ratio during synthesis to generate more Oxygen Vacancies (doping).
Trace Organics in GC	Contamination from synthesis.	Ensure thorough Ethanol washing (Step 2.2.4) and pre-irradiation cleaning.
Catalyst Instability	Fluorine leaching.	Check pH of solution. BiOF is stable in neutral/acidic pH but hydrolyzes in strong alkali.

References

- Zhang, L. et al. (2020).[3] Small-molecule surface-modified bismuth-based semiconductors as a new class of visible-light-driven photocatalytic materials. Chemical Engineering Journal. [3] [Link](#)
- Li, M. et al. (2018).[3] Facet, Junction and Electric Field Engineering of Bismuth-Based Materials for Photocatalysis.[3] ChemCatChem.[3] [Link](#)
- Cheng, H. et al. (2022). Efficient CO₂ Photoreduction Triggered by Oxygen Vacancies in Ultrafine Bi₅O₇Br Nanowires.[4] Applied Catalysis B: Environmental. [Link](#)
- Wang, S. et al. (2023). BiOCl Nanoflowers with High Levels of Oxygen Vacancy for Photocatalytic CO₂ Reduction.[4][5] ACS Applied Nano Materials. [Link](#)

- Dhakshinamoorthy, A. et al. (2025). Photocatalytic CO₂ reduction by TiO₂ and related titanium containing solids (Comparative Mechanism). MDPI. [Link](#)

Need Custom Synthesis?

BenchChem offers custom synthesis for rare earth carbides and specific isotopic labeling.

Email: info@benchchem.com or [Request Quote Online](#).

Sources

- 1. [mdpi.com](https://www.mdpi.com) [[mdpi.com](https://www.mdpi.com)]
- 2. [researchgate.net](https://www.researchgate.net) [[researchgate.net](https://www.researchgate.net)]
- 3. [mdpi.com](https://www.mdpi.com) [[mdpi.com](https://www.mdpi.com)]
- 4. [researchgate.net](https://www.researchgate.net) [[researchgate.net](https://www.researchgate.net)]
- 5. pubs.acs.org [pubs.acs.org]
- To cite this document: BenchChem. [Application Note: High-Precision Synthesis and Photocatalytic Application of Bismuth Oxyfluoride (BiOF)]. BenchChem, [2026]. [Online PDF]. Available at: [<https://www.benchchem.com/product/b1329470/docs#application-note-high-precision-synthesis-and-photocatalytic-application-of-bismuth-oxyfluoride-biof>]

Disclaimer & Data Validity:

The information provided in this document is for Research Use Only (RUO) and is strictly not intended for diagnostic or therapeutic procedures. While BenchChem strives to provide accurate protocols, we make no warranties, express or implied, regarding the fitness of this product for every specific experimental setup.

Technical Support: The protocols provided are for reference purposes. Unsure if this reagent suits your experiment?

Need Industrial/Bulk Grade? [Request Custom Synthesis Quote](#)

BenchChem

Our mission is to be the trusted global source of essential and advanced chemicals, empowering scientists and researchers to drive progress in science and industry.

Contact

Address: 3281 E Guasti Rd

Ontario, CA 91761, United States

Phone: (601) 213-4426

Email: info@benchchem.com

[Contact our Ph.D. Support Team for a compatibility check](#)