

Crystal Structure Determination of Thiophene-Containing β -Lactams: From Synthesis to Structural Validation

Author: BenchChem Technical Support Team. **Date:** April 2026

Compound of Interest

Compound Name: 4-(5-Methylthiophen-3-yl)azetidin-2-one
Cat. No.: B13287735

[Get Quote](#)

Foreword: The Imperative for Structural Clarity in Antibiotic Development

The β -lactam class of antibiotics represents a cornerstone of modern medicine, fundamentally altering our ability to combat bacterial infections.[1][2][3] However, the relentless rise of antimicrobial resistance (AMR) threatens to undermine these life-saving therapeutics, creating an urgent need for novel chemical entities that can circumvent bacterial defense mechanisms.[4][5] Thiophene-containing β -lactams have emerged as a particularly promising frontier in this battle. The incorporation of the thiophene motif into the β -lactam scaffold can significantly modulate the compound's electronic properties and steric profile, leading to enhanced potency and activity against resistant strains.[6][7][8][9]

To rationally design the next generation of these potent antibiotics, a deep, atomic-level understanding of their three-dimensional structure is not merely beneficial—it is essential. The precise spatial arrangement of atoms dictates how a molecule interacts with its biological target, such as penicillin-binding proteins (PBPs), and how it is recognized (or ignored) by

resistance enzymes like β -lactamases.[4][10] Single-crystal X-ray diffraction is the gold standard for obtaining this information, providing unambiguous proof of molecular structure and stereochemistry.[11][12]

This guide provides researchers, chemists, and drug development professionals with a comprehensive, field-proven walkthrough of the entire crystal structure determination workflow for thiophene-containing β -lactams. We will move beyond a simple recitation of steps to explore the causality behind experimental choices, from the initial synthesis and crystallization to the final stages of data analysis, validation, and deposition. Our focus is on building a self-validating system of protocols that ensures the generation of high-quality, reliable, and publishable crystallographic data.

Part 1: The Foundation - Synthesis and Crystallization

The journey to a crystal structure begins long before the X-ray diffractometer. The quality of the final structural model is inextricably linked to the purity of the synthesized compound and the success of the crystallization experiment.

Synthesis and Purification: The Prerequisite for Quality Crystals

The synthesis of thiophene-containing β -lactams typically involves well-established organic chemistry reactions. The Staudinger [2+2] cycloaddition of a ketene with an imine and the Kinugasa reaction are two powerful methods frequently employed to construct the core β -lactam ring.[13][14] The choice of synthetic route is critical, as it must not only be efficient but also yield a product that can be rigorously purified.

Causality Behind Purity: Impurities, including minor stereoisomers or residual solvents, can act as "crystal growth inhibitors." They disrupt the highly ordered, repeating lattice structure required for diffraction, leading to poorly formed crystals, twinning, or a complete failure to crystallize. Therefore, meticulous purification, typically via column chromatography followed by recrystallization, is a non-negotiable first step.

The Art of Crystal Growth: Navigating Supersaturation

Crystallization is the controlled precipitation of a solid from a supersaturated solution. For small, organic molecules like thiophene- β -lactams, several techniques can be employed to achieve this state. The choice of method is often empirical, but an understanding of their mechanisms can guide the experimental design.

Key Crystallization Techniques:

- **Slow Evaporation:** A solution of the compound is left in a loosely covered vial, allowing the solvent to evaporate slowly over days or weeks. This gradually increases the concentration, pushing the system towards supersaturation and inducing crystal growth.^[15]
- **Vapor Diffusion:** This method involves placing a concentrated solution of the compound in a small, open vial, which is then sealed inside a larger jar containing a more volatile "anti-solvent" in which the compound is insoluble. The anti-solvent vapor slowly diffuses into the compound's solution, reducing its solubility and causing crystallization.
- **Cooling Crystallization:** A nearly saturated solution of the compound is prepared at an elevated temperature and then allowed to cool slowly. As the temperature drops, the solubility decreases, leading to the formation of crystals.^[16]^[17] This method can be particularly effective but must be carefully controlled to prevent rapid precipitation, which yields small, poor-quality crystals.

Protocol 1: Step-by-Step Slow Evaporation Crystallization

- **Solvent Screening:** In a series of small vials, test the solubility of ~1-2 mg of your purified compound in a range of solvents (e.g., acetone, acetonitrile, ethyl acetate, methanol, dichloromethane, toluene). The ideal solvent is one in which the compound is moderately soluble.^[15]
- **Preparation of Saturated Solution:** Dissolve 5-10 mg of the purified thiophene- β -lactam in the chosen solvent. Gently warm the mixture if necessary to ensure complete dissolution.
- **Filtration:** Filter the solution through a syringe filter (0.22 μ m pore size) into a clean, dust-free vial. This step is critical to remove any particulate matter that could act as unwanted nucleation sites.

- Incubation: Cover the vial with parafilm and pierce it with a needle 1-2 times to allow for slow evaporation.
- Patience: Place the vial in a vibration-free location (e.g., a dedicated cupboard or a drawer) at a constant temperature. Do not disturb the vial. Crystal growth can take anywhere from a few days to several weeks.

Table 1: Comparison of Crystallization Techniques for Thiophene- β -Lactams

Technique	Principle	Advantages	Disadvantages & Causality
Slow Evaporation	Gradual increase in concentration as solvent evaporates.	Simple setup; effective for many compounds.	Can be slow; may lead to "oiling out" if solvent evaporates too quickly or if solubility curve is steep.
Vapor Diffusion	Gradual decrease in solubility via diffusion of an anti-solvent.	High degree of control; excellent for sensitive compounds.	Requires careful selection of solvent/anti-solvent pair; more complex setup.
Cooling Crystallization	Decrease in solubility with decreasing temperature.	Can be rapid; useful for compounds with high temperature-dependent solubility.	Risk of rapid precipitation yielding microcrystals; β -lactam ring can be susceptible to degradation at elevated temperatures. ^{[16][17]}

Expert Insight: Overcoming Challenges

Thiophene rings have a propensity for π -stacking, which can sometimes lead to disordered structures.^{[18][19]} Furthermore, the β -lactam ring itself can be unstable and prone to

hydrolysis.[16] If initial crystallization attempts fail, consider using co-crystallization agents or screening a wider range of solvents and temperatures. The goal is to find a condition that balances kinetic and thermodynamic factors to favor the growth of a single, well-ordered crystal.

Part 2: The Experiment - Single-Crystal X-ray Diffraction

Once a suitable crystal is obtained, the next phase is to use X-rays to probe its internal structure.

From Crystal to Diffractometer: Sample Handling and Instrumentation

The ideal crystal for single-crystal X-ray diffraction is typically between 0.02 and 0.3 mm in all dimensions, with sharp edges and no visible cracks or defects.[12]

- **Crystal Selection & Mounting:** Under a microscope, select a high-quality crystal and carefully mount it on a glass fiber or a cryo-loop using a minimal amount of inert oil (e.g., paratone-N).
- **Cryo-cooling:** The mounted crystal is immediately flash-cooled in a stream of cold nitrogen gas (typically at 100 K). This is a critical step. The low temperature minimizes thermal vibrations of the atoms, leading to a sharper diffraction pattern and higher resolution data. It also protects the crystal from radiation damage during the experiment.
- **Centering:** The crystal is mounted on the goniometer head of the diffractometer and precisely centered in the X-ray beam. Modern systems often use AI-based methods for automated and accurate centering.[20]

The Experimental Workflow: A Visual Guide

The process from a grown crystal to a raw diffraction dataset follows a logical sequence.

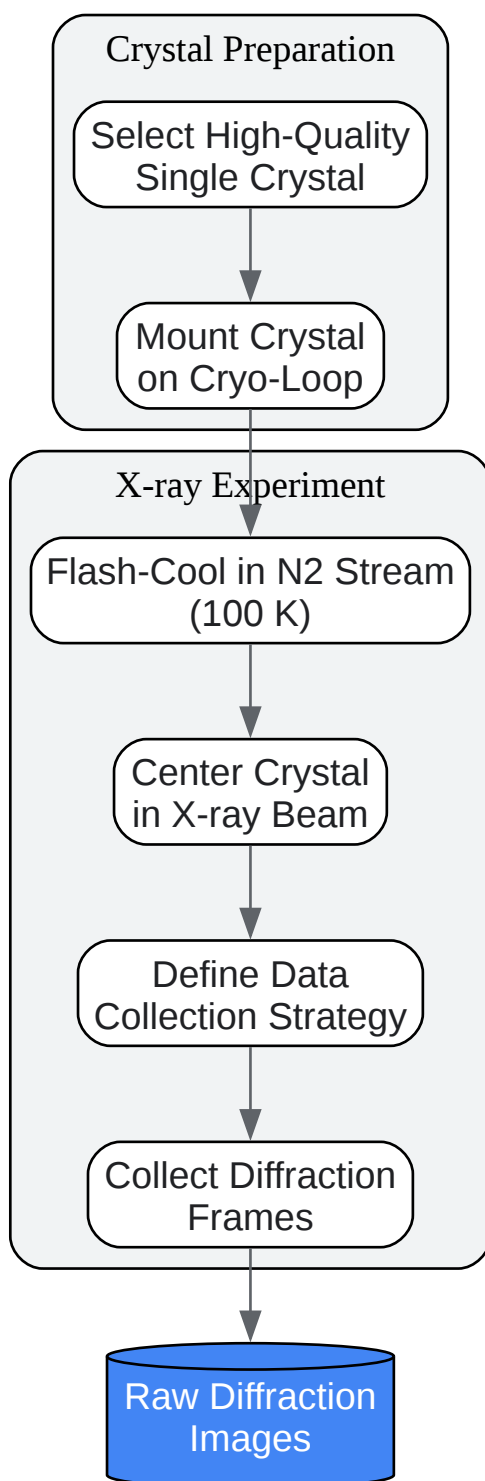

[Click to download full resolution via product page](#)

Caption: Experimental workflow from crystal mounting to raw data collection.

Data Collection Strategy: Asking the Right Questions

A modern diffractometer does not simply irradiate the crystal; it executes a pre-defined strategy to collect a complete and redundant dataset.

- **X-ray Source:** For routine analysis of organic compounds, a Molybdenum (Mo) $K\alpha$ source ($\lambda \approx 0.71 \text{ \AA}$) is standard. However, for determining the absolute configuration of chiral molecules—a necessity for biologically active compounds—a Copper (Cu) $K\alpha$ source ($\lambda \approx 1.54 \text{ \AA}$) is often superior due to its anomalous scattering effect.^{[12][21]}
- **Exposure Time & Scan Width:** The detector collects a series of images (frames) as the crystal is rotated. The exposure time per frame and the rotation width (e.g., 0.5°) are adjusted to maximize the signal-to-noise ratio without overloading the detector.
- **Completeness and Redundancy:** The strategy ensures the crystal is rotated through a sufficient angular range to measure the intensity of nearly all unique reflections (high completeness) and to measure many of them multiple times (high redundancy), which is crucial for accurate data scaling and error analysis.

Part 3: The Analysis - From Diffraction to Structure

The collected diffraction images are not a direct picture of the molecule but a reciprocal space map of its structure. A multi-step computational process is required to translate this pattern back into a 3D atomic model.

Data Processing Pipeline

The raw frames are processed to extract meaningful intensity data for each reflection. This involves integration, scaling, and absorption corrections.

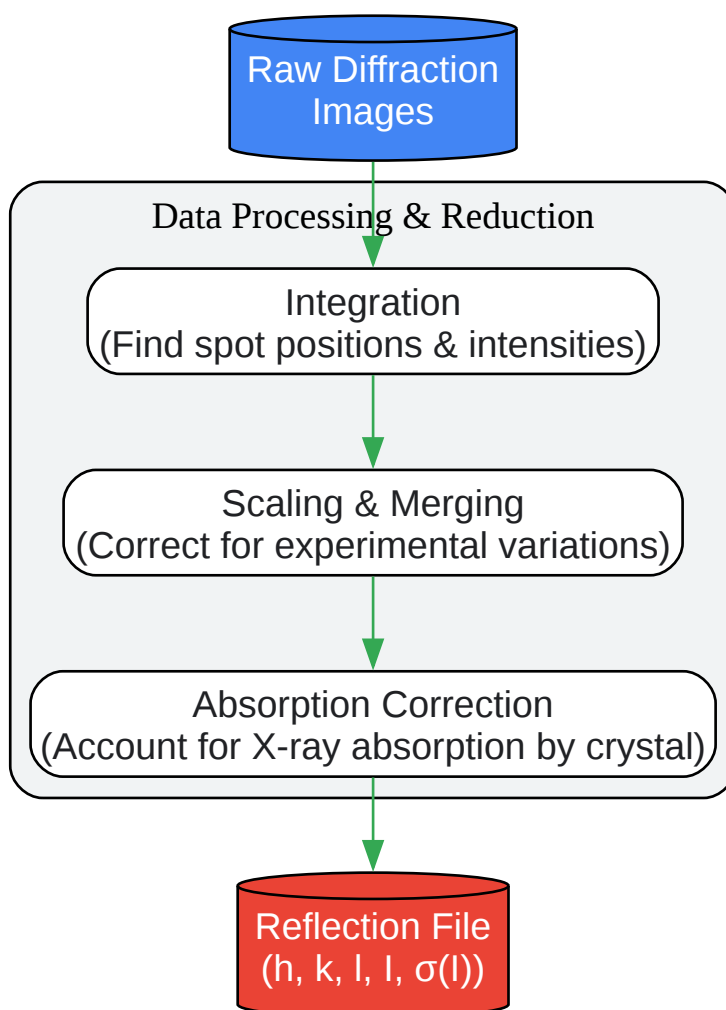

[Click to download full resolution via product page](#)

Caption: The data processing pipeline converting raw images to a reflection file.

This process is handled by sophisticated software suites like Bruker's APEX[20], or standalone programs like XDS and DIALS.[22] The output is a reflection file containing the Miller indices (h,k,l) and the measured intensity (I) with its standard uncertainty ($\sigma(I)$) for each reflection.

Structure Solution and Refinement

- Solving the Phase Problem: The reflection file gives us the intensities (related to the amplitude of the scattered waves) but not their phases. This is the infamous "phase problem" of crystallography. For small molecules, Direct Methods are powerful statistical approaches that can determine initial phase estimates directly from the intensity data, leading to a preliminary electron density map.

- **Model Building:** From this initial map, a chemist can often recognize molecular fragments (like the thiophene or β -lactam rings) and build an initial structural model.
- **Refinement:** This iterative process uses a least-squares algorithm to adjust the atomic parameters (positional coordinates, atomic displacement parameters) of the model to improve the agreement between the calculated diffraction pattern (from the model) and the experimentally observed pattern. This is typically performed with software like SHELXL.[\[22\]](#)

Key Refinement Metrics:

The quality of the final model is assessed by several statistical indicators.

Parameter	Description	Typical Target Value (Good Quality)
R1	The residual factor, a measure of the agreement between observed and calculated structure factor amplitudes.	< 0.05 (5%)
wR2	A weighted residual factor based on intensities, generally considered a more robust indicator.	< 0.12 (12%)
GooF	Goodness-of-Fit. Should be close to 1.0, indicating a good model and appropriate data weighting.	~1.0

Part 4: Validation and Deposition - Ensuring Scientific Integrity

A solved and refined structure is not the end of the process. Rigorous validation and public deposition are essential for scientific trustworthiness.

Structure Validation: The checkCIF Mandate

Before any structure is considered complete, it must be validated. The International Union of Crystallography (IUCr) provides a free online service called checkCIF for this purpose.[\[23\]](#)[\[24\]](#)[\[25\]](#)

Protocol 2: Validating Your Structure

- **Generate a CIF:** Your refinement software will generate a Crystallographic Information File (CIF). This is a standardized text file containing all relevant information about the experiment and the final structural model.[\[25\]](#)
- **Submit to checkCIF:** Upload your CIF to the IUCr's checkCIF web service (checkcif.iucr.org).[\[23\]](#)
- **Analyze the Report:** The service will return a PDF report with a list of "ALERTS." These are potential issues flagged by the software.
 - **A-level Alerts:** Serious issues that must be addressed (e.g., incorrect space group, major geometric inconsistencies).
 - **B-level Alerts:** Potentially serious issues that require investigation and explanation.
 - **C-level and G-level Alerts:** Less severe, often informational, but should still be reviewed.
- **Resolve or Explain:** You must go back to your model and resolve any errors. For alerts that cannot be resolved but have a valid chemical explanation, you must provide a written response in the CIF. A clean, well-explained checkCIF report is a hallmark of a high-quality structure determination.

Data Deposition: Contributing to the Global Scientific Record

For small organic and metal-organic compounds, the definitive repository is the Cambridge Structural Database (CSD), managed by the Cambridge Crystallographic Data Centre (CCDC).[\[23\]](#)[\[26\]](#) Most reputable scientific journals require a CCDC deposition number before a manuscript describing a crystal structure can be published.

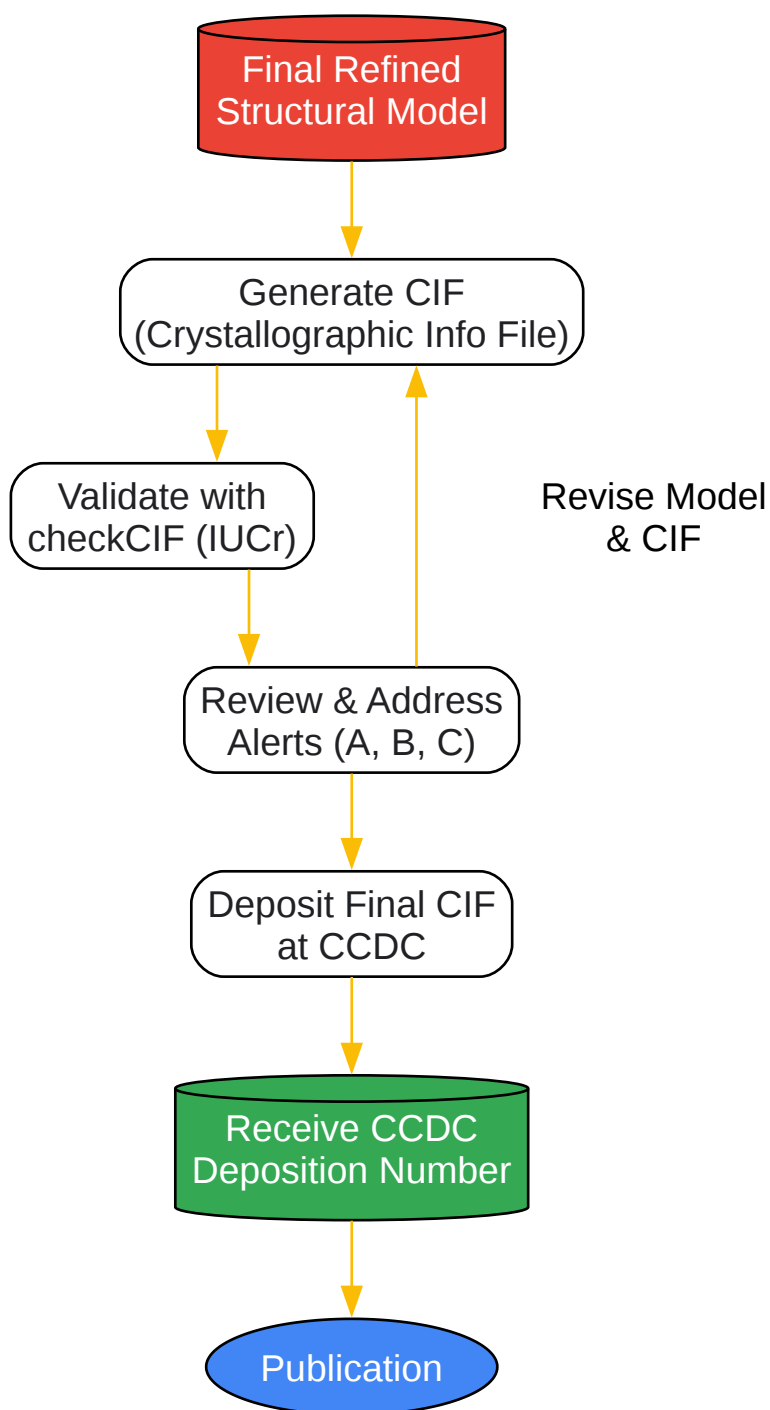

[Click to download full resolution via product page](#)

Caption: The workflow for structure validation and public deposition.

This final step ensures that your data is preserved, accessible to other scientists, and contributes to the collective knowledge of chemical structures, fostering further discovery and innovation in fields like drug development.

Conclusion: From Atoms to Antibiotics

The determination of the crystal structure of a thiophene-containing β -lactam is a rigorous, multi-stage process that demands both experimental skill and analytical precision. Each step, from the initial synthesis to the final deposition, is a critical link in a chain that leads to an unambiguous, atomic-resolution model of the molecule. This structural information is invaluable. It provides definitive proof of constitution and stereochemistry, illuminates subtle conformational features, and serves as the foundation for computational modeling and structure-activity relationship (SAR) studies.^{[7][8][27]} By understanding precisely how the thiophene moiety and other substituents are oriented in three-dimensional space, medicinal chemists can make rational, data-driven decisions to design more potent, selective, and resistance-evading β -lactam antibiotics, addressing one of the most significant challenges to global health.

References

- Synthesis and Biological Screening of Thiophene Derivatives. (n.d.). ResearchGate. Retrieved March 7, 2026, from [\[Link\]](#)
- Preliminary profile of structure-activity relationship for thiophene embedded spirocyclic- β -lactams 7–8. (n.d.). ResearchGate. Retrieved March 7, 2026, from [\[Link\]](#)
- APEX Software. (n.d.). Bruker. Retrieved March 7, 2026, from [\[Link\]](#)
- Requirements for Depositing X-Ray Crystallographic Data. (n.d.). American Chemical Society. Retrieved March 7, 2026, from [\[Link\]](#)
- X-Ray Data Analysis Software Packages. (n.d.). Materials Research Laboratory, University of Illinois. Retrieved March 7, 2026, from [\[Link\]](#)
- Deposit. (n.d.). The Cambridge Crystallographic Data Centre (CCDC). Retrieved March 7, 2026, from [\[Link\]](#)
- Buynak, J. D., et al. (2006). Structure-activity relationship of 6-methylidene penems bearing 6,5 bicyclic heterocycles as broad-spectrum beta-lactamase inhibitors: evidence for 1,4-thiazepine intermediates with C7 R stereochemistry by computational methods. *Journal of Medicinal Chemistry*, 49(15), 4546-59. Retrieved March 7, 2026, from [\[Link\]](#)

- Encarnación-Gómez, L. G., et al. (2020). Reactive crystallization of β -lactam antibiotics: strategies to enhance productivity and purity of ampicillin. *Reaction Chemistry & Engineering*, 5, 1201-1210. Retrieved March 7, 2026, from [\[Link\]](#)
- FullProf Suite. (n.d.). Retrieved March 7, 2026, from [\[Link\]](#)
- MX-Software. (n.d.). Diamond Light Source. Retrieved March 7, 2026, from [\[Link\]](#)
- Example thiophene-containing β -lactam antibiotics and antifungal agents. (n.d.). ResearchGate. Retrieved March 7, 2026, from [\[Link\]](#)
- CIF Deposition Guidelines. (n.d.). The Cambridge Crystallographic Data Centre (CCDC). Retrieved March 7, 2026, from [\[Link\]](#)
- Ooshima, H., et al. (2021). Polymorphic Crystallization Design to Prevent the Degradation of the β -Lactam Structure of a Carbapenem. *Crystals*, 11(8), 931. Retrieved March 7, 2026, from [\[Link\]](#)
- Model development for enzymatic reactive crystallization of β -lactam antibiotics: a reaction–diffusion-crystallization approach. (2020). *Reaction Chemistry & Engineering*, 5, 2197-2209. Retrieved March 7, 2026, from [\[Link\]](#)
- Spek, A. L. (2009). Structure validation in chemical crystallography. *Acta Crystallographica Section D: Biological Crystallography*, 65(Pt 2), 148–155. Retrieved March 7, 2026, from [\[Link\]](#)
- Synthesis, Characterization and Structure Activity Relationship Studies of Benzo[b]thiophene Derivatives as Promising Class of Antimicrobial Agents. (n.d.). ResearchGate. Retrieved March 7, 2026, from [\[Link\]](#)
- CIF - Crystallographic Information Framework. (n.d.). Digital Curation Centre. Retrieved March 7, 2026, from [\[Link\]](#)
- Reactive crystallization of β -lactam antibiotics: Strategies to enhance productivity and purity of ampicillin. (n.d.). ResearchGate. Retrieved March 7, 2026, from [\[Link\]](#)

- Synthesis and stereochemistry of 3-(thiophen-2-yl)- β -lactams. (2015). ResearchGate. Retrieved March 7, 2026, from [\[Link\]](#)
- Polymorphic Crystallization Design to Prevent the Degradation of the β -Lactam Structure of a Carbapenem. (2021). ResearchGate. Retrieved March 7, 2026, from [\[Link\]](#)
- Small molecule X-ray crystallography. (n.d.). The University of Queensland. Retrieved March 7, 2026, from [\[Link\]](#)
- Miller, M. D., et al. (2020). The Chemical Relationship Among Beta-Lactam Antibiotics and Potential Impacts on Reactivity and Decomposition. *Frontiers in Chemistry*, 8, 523. Retrieved March 7, 2026, from [\[Link\]](#)
- How To: Grow X-Ray Quality Crystals. (n.d.). University of Rochester, Department of Chemistry. Retrieved March 7, 2026, from [\[Link\]](#)
- Small molecule crystallography. (n.d.). Excillum. Retrieved March 7, 2026, from [\[Link\]](#)
- Thiophene-Based Covalent Organic Frameworks: Synthesis, Photophysics and Light-Driven Applications. (2021). *Molecules*, 26(24), 7666. Retrieved March 7, 2026, from [\[Link\]](#)
- Adjusting the Crystallization of Tin Perovskites through Thiophene Additives for Improved Photovoltaic Stability. (2022). *ACS Energy Letters*, 7(11), 3848–3855. Retrieved March 7, 2026, from [\[Link\]](#)
- β -Lactam antibiotic. (n.d.). Wikipedia. Retrieved March 7, 2026, from [\[Link\]](#)
- Absolute Configuration of Small Molecules by Co-Crystallization. (2018). *Angewandte Chemie International Edition*, 57(42), 13813–13818. Retrieved March 7, 2026, from [\[Link\]](#)
- Paterka, M., et al. (2023). Beta-Lactam Antibiotics. In *StatPearls*. StatPearls Publishing. Retrieved March 7, 2026, from [\[Link\]](#)
- Crystal structures of four chiral imine-substituted thiophene derivatives. (2016). *Acta Crystallographica Section E: Crystallographic Communications*, 72(Pt 1), 69–74. Retrieved March 7, 2026, from [\[Link\]](#)

- Liquid Crystalline Materials Containing Thiophene Rings. (2019). *Crystal Growth & Design*, 19(7), 4149–4167. Retrieved March 7, 2026, from [\[Link\]](#)
- Synthesis of Thiophene-Based Derivatives and the Effects of Their Molecular Structure on the Mesomorphic Behavior and Temperature Range of Liquid-Crystalline Blue Phases. (2023). *Molecules*, 28(12), 4648. Retrieved March 7, 2026, from [\[Link\]](#)
- Bush, K., & Bradford, P. A. (2016). β -Lactams and β -Lactamase Inhibitors: An Overview. *Cold Spring Harbor Perspectives in Medicine*, 6(8), a025247. Retrieved March 7, 2026, from [\[Link\]](#)
- β -Lactam potentiators to re-sensitize resistant pathogens: Discovery, development, clinical use and the way forward. (2022). *Frontiers in Microbiology*, 13, 1022262. Retrieved March 7, 2026, from [\[Link\]](#)
- Beta-Lactam Antibiotics Evolution, Mechanisms, and Modern Applications. (2025). ResearchGate. Retrieved March 7, 2026, from [\[Link\]](#)
- Medicinal chemistry-based perspectives on thiophene and its derivatives: exploring structural insights to discover plausible druggable leads. (2023). *RSC Medicinal Chemistry*, 14(10), 1856–1896. Retrieved March 7, 2026, from [\[Link\]](#)
- β -Lactam synthesis. (n.d.). Organic Chemistry Portal. Retrieved March 7, 2026, from [\[Link\]](#)

Need Custom Synthesis?

BenchChem offers custom synthesis for rare earth carbides and specific isotopic labeling.

Email: info@benchchem.com or [Request Quote Online](#).

Sources

- [1. \$\beta\$ -Lactam antibiotic - Wikipedia \[en.wikipedia.org\]](#)
- [2. Beta-Lactam Antibiotics - StatPearls - NCBI Bookshelf \[ncbi.nlm.nih.gov\]](#)
- [3. researchgate.net \[researchgate.net\]](#)
- [4. \$\beta\$ -Lactams and \$\beta\$ -Lactamase Inhibitors: An Overview - PMC \[pmc.ncbi.nlm.nih.gov\]](#)

- [5. Frontiers | \$\beta\$ -Lactam potentiators to re-sensitize resistant pathogens: Discovery, development, clinical use and the way forward \[frontiersin.org\]](#)
- [6. researchgate.net \[researchgate.net\]](#)
- [7. researchgate.net \[researchgate.net\]](#)
- [8. Structure-activity relationship of 6-methylidene penems bearing 6,5 bicyclic heterocycles as broad-spectrum beta-lactamase inhibitors: evidence for 1,4-thiazepine intermediates with C7 R stereochemistry by computational methods - PubMed \[pubmed.ncbi.nlm.nih.gov\]](#)
- [9. researchgate.net \[researchgate.net\]](#)
- [10. The Chemical Relationship Among Beta-Lactam Antibiotics and Potential Impacts on Reactivity and Decomposition - PMC \[pmc.ncbi.nlm.nih.gov\]](#)
- [11. X-ray Crystallography | Anton Paar Wiki \[wiki.anton-paar.com\]](#)
- [12. Small molecule X-ray crystallography - School of Chemistry and Molecular Biosciences - University of Queensland \[scmb.uq.edu.au\]](#)
- [13. researchgate.net \[researchgate.net\]](#)
- [14. \$\beta\$ -Lactam synthesis \[organic-chemistry.org\]](#)
- [15. How To \[chem.rochester.edu\]](#)
- [16. mdpi.com \[mdpi.com\]](#)
- [17. researchgate.net \[researchgate.net\]](#)
- [18. mdpi.com \[mdpi.com\]](#)
- [19. Crystal structures of four chiral imine-substituted thiophene derivatives - PMC \[pmc.ncbi.nlm.nih.gov\]](#)
- [20. APEX Software | Bruker \[bruker.com\]](#)
- [21. Absolute Configuration of Small Molecules by Co-Crystallization - PMC \[pmc.ncbi.nlm.nih.gov\]](#)
- [22. diamond.ac.uk \[diamond.ac.uk\]](#)
- [23. pubsapp.acs.org \[pubsapp.acs.org\]](#)
- [24. Structure validation in chemical crystallography - PMC \[pmc.ncbi.nlm.nih.gov\]](#)
- [25. CIF - Crystallographic Information Framework | DCC \[dcc.ac.uk\]](#)
- [26. Deposit - The Cambridge Crystallographic Data Centre \(CCDC\) \[ccdc.cam.ac.uk\]](#)
- [27. researchgate.net \[researchgate.net\]](#)

- To cite this document: BenchChem. [Crystal Structure Determination of Thiophene-Containing β -Lactams: From Synthesis to Structural Validation]. BenchChem, [2026]. [Online PDF]. Available at: [<https://www.benchchem.com/product/b13287735/docs#crystal-structure-determination-of-thiophene-containing-lactams-from-synthesis-to-structural-validation>]

Disclaimer & Data Validity:

The information provided in this document is for Research Use Only (RUO) and is strictly not intended for diagnostic or therapeutic procedures. While BenchChem strives to provide accurate protocols, we make no warranties, express or implied, regarding the fitness of this product for every specific experimental setup.

Technical Support: The protocols provided are for reference purposes. Unsure if this reagent suits your experiment?

Need Industrial/Bulk Grade? [Request Custom Synthesis Quote](#)

BenchChem

Our mission is to be the trusted global source of essential and advanced chemicals, empowering scientists and researchers to drive progress in science and industry.

Contact

Address: 3281 E Guasti Rd
Ontario, CA 91761, United States
Phone: (601) 213-4426
Email: info@benchchem.com

[Contact our Ph.D. Support Team for a compatibility check](#)