

Pharmacological Potential of Substituted Benzophenones: A Technical Guide

Author: BenchChem Technical Support Team. **Date:** February 2026

Compound of Interest

Compound Name:	4-Chloro-2-fluoro-2'-piperidinomethyl benzophenone
CAS No.:	898773-63-2
Cat. No.:	B1327268

[Get Quote](#)

Executive Summary

The benzophenone (diphenyl ketone) scaffold represents a "privileged structure" in medicinal chemistry—a molecular framework capable of providing useful ligands for more than one receptor or enzyme target by judicious structural modifications. While historically known for their utility as UV filters, substituted benzophenones have emerged as potent pharmacological agents. This guide dissects their utility in two primary high-value verticals: microtubule-targeting antimitotics (synthetic derivatives) and pleiotropic anticancer/antimicrobial agents (natural polyisoprenylated benzophenones).

Part 1: Chemical Architecture & Structure-Activity Relationships (SAR)

The pharmacological versatility of benzophenones stems from the ability of the central carbonyl bridge to orient the two phenyl rings (A and B) in a non-planar conformation, mimicking the twisted geometry of bioactive biaryls like combretastatin A-4.

Core SAR Logic

- **The Bridge:** The carbonyl linker provides hydrogen bond acceptor capability and maintains the requisite "twist" for fitting into hydrophobic pockets (e.g., the colchicine binding site on

tubulin).

- Ring A (Polymethoxylation): Analogous to the trimethoxyphenyl ring of colchicine, 3,4,5-trimethoxy substitution often maximizes affinity for tubulin.
- Ring B (Lipophilicity & H-Bonding): Substitution at the 3'- or 4'-position with hydroxyl or amino groups enhances cytotoxicity. Ortho-substitution (2'-position) often restricts rotation, locking the molecule in a bioactive conformation.
- Prenylation (Natural Products): The addition of prenyl or geranyl chains (common in Clusiaceae metabolites) drastically increases lipophilicity, facilitating membrane permeation and interaction with hydrophobic enzymatic pockets (e.g., HIV-1 Reverse Transcriptase).

Visualization: SAR Decision Matrix

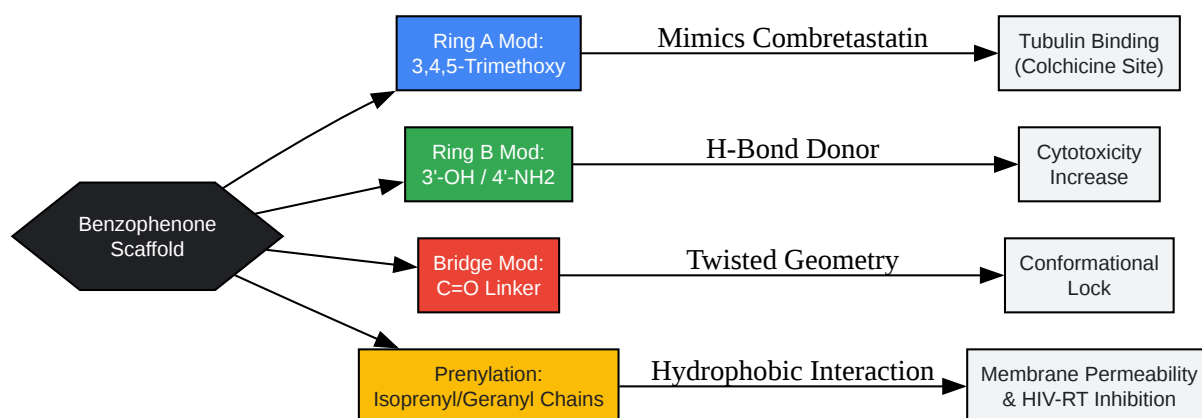

[Click to download full resolution via product page](#)

Figure 1: Structural modifications of the benzophenone scaffold and their direct pharmacological consequences.

Part 2: Therapeutic Verticals

Oncology: Microtubule Destabilization

Synthetic benzophenones (e.g., phenstatin analogues) act as Microtubule Targeting Agents (MTAs). They bind to the colchicine site of

-tubulin, inhibiting polymerization.[1]

- Mechanism: Binding prevents the formation of the mitotic spindle.
- Outcome: Cells arrest in the G2/M phase, leading to the collapse of mitochondrial membrane potential () and subsequent apoptosis.
- Key Compound: Phenstatin is the archetype, but recent derivatives (e.g., amino-benzophenones) show IC50 values in the nanomolar range (20-60 nM) against MDR cell lines.

Natural Products: Polyisoprenylated Benzophenones

Derived from plants like *Garcinia* and *Clusia*, compounds such as Guttiferone E and Nemorosone exhibit a distinct mechanism.

- ER Stress Induction: These compounds trigger the Unfolded Protein Response (UPR), upregulating markers like XBP1 and CHOP.
- mTOR Inhibition: They downregulate the mTOR survival pathway, distinct from the tubulin mechanism of their synthetic cousins.

Visualization: Mechanism of Action (Oncology)

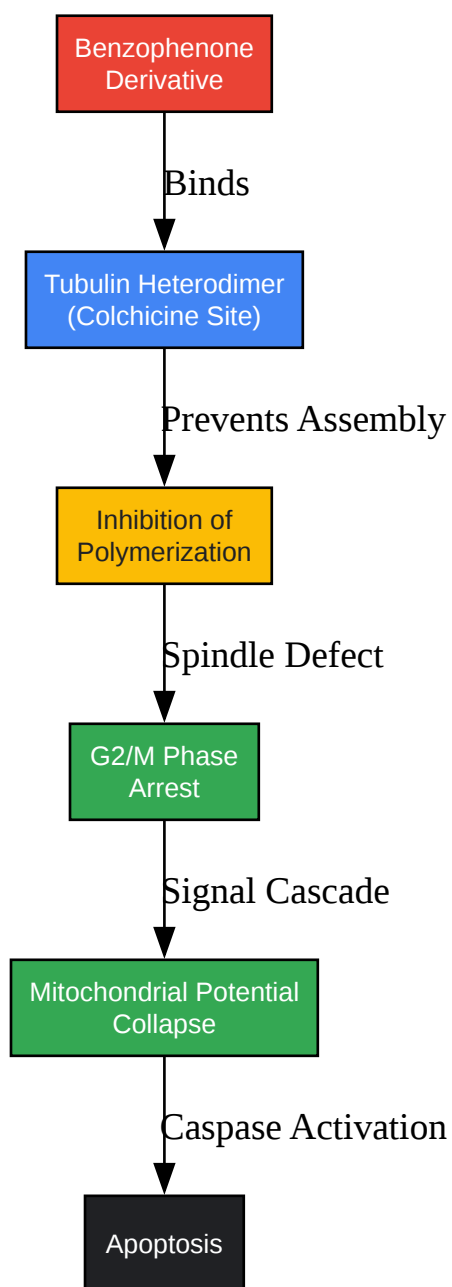

[Click to download full resolution via product page](#)

Figure 2: The cascade of events triggered by benzophenone-based tubulin inhibitors, leading from molecular binding to cell death.

Part 3: Synthesis & Optimization Strategies

For medicinal chemists, the Friedel-Crafts Acylation remains the most robust route for synthesizing the benzophenone core.

Optimized Synthetic Protocol

- Reagents: Benzoyl chloride derivative (electrophile) + Substituted benzene (nucleophile).
- Catalyst: Aluminum Chloride () is standard, but modern "green" adaptations use zeolites or triflates to minimize waste.
- Solvent: Dichloromethane (DCM) or 1,2-dichloroethane.

Critical Note: When synthesizing polymethoxylated derivatives (common for tubulin inhibitors), can sometimes cause demethylation. In such cases, milder Lewis acids or carefully controlled temperatures () are required.

Part 4: Technical Protocols

Protocol A: Tubulin Polymerization Assay (Fluorescence-Based)

Validates the mechanism of action for antimitotic benzophenones.

Principle: Tubulin polymerization is monitored by the increase in fluorescence of a reporter dye (DAPI) which binds to microtubules but not unpolymerized tubulin dimers.

Reagents:

- Purified Porcine Brain Tubulin (>99% pure).
- G-PEM Buffer: 80 mM PIPES (pH 6.9), 2 mM , 0.5 mM EGTA, 1 mM GTP, 10% Glycerol.[2]
- Reporter: 10 M DAPI.

Step-by-Step Workflow:

- Preparation: Pre-warm a 96-well black plate to 37°C.
- Compound Addition: Add 5 μ L of the test benzophenone (dissolved in DMSO) to the wells. Include a Paclitaxel control (stabilizer) and a Vinblastine control (destabilizer).
- Tubulin Addition: Add 55 μ L of Tubulin/G-PEM/DAPI master mix to each well. Final tubulin concentration should be ~2-3 mg/mL.
- Kinetics: Immediately place in a fluorescence microplate reader (Ex 340 nm / Em 410-460 nm).
- Measurement: Read every 60 seconds for 60-90 minutes at 37°C.
- Analysis: Plot RFU vs. Time. Calculate the R^2 of the growth phase. Effective benzophenones will flatten the curve similar to Vinblastine.

Protocol B: In Vitro Cytotoxicity (MTS Assay)

Determines the potency (IC₅₀) of the synthesized compounds.

- Seeding: Seed cancer cells (e.g., HeLa, MCF-7) at 10,000 cells/well in 96-well plates.
 - Expert Insight: Do not over-seed. Benzophenones are cell-cycle specific; cells must be in the exponential growth phase for the drug to work.
- Incubation: Allow attachment for 24 hours.
- Treatment: Add serial dilutions of benzophenones. Incubate for 48-72 hours.
- Development: Add MTS reagent. Incubate 1-4 hours. Read absorbance at 490 nm.

Part 5: Comparative Data Analysis

The following table summarizes the structure-activity trends observed in recent literature regarding benzophenone-based tubulin inhibitors.

Compound Class	Key Substitution	Target	IC50 (MDR Cell Lines)	Mechanism Note
Phenstatin	3'-OH, 4'-OMe	Tubulin	~250 nM	Parent compound; potent but metabolically labile.
Amino-BP	2'-NH2 (Ortho)	Tubulin	20-60 nM	Ortho-amino group locks conformation; superior potency.
Polyisoprenylated	Geranyl chains	Non-Specific	1-10 μ M	Lower potency but broader spectrum (ER stress + ROS).
Combretastatin A-4	(Stilbene control)	Tubulin	1-5 nM	Reference standard; limited by solubility/isomerization.

Data synthesized from Zhang et al. (RSC Adv) and related SAR studies.

References

- Zhang, S., et al. (2016).[1] The synthesis and evaluation of new benzophenone derivatives as tubulin polymerization inhibitors.[1][3] RSC Advances.[3] [Link](#)
- Surana, K., et al. (2018).[4][5] Benzophenone: a ubiquitous scaffold in medicinal chemistry. [4][6][7] MedChemComm.[4] [Link](#)

- Ciochina, R. & Grossman, R.B. (2006). Polycyclic polyprenylated acylphloroglucinols. Chemical Reviews.
- BenchChem Protocols. (2025). Synthesis of Benzophenones via Friedel-Crafts Acylation.[8][9][10][Link](#)
- NIH PubChem.Compound Summary: Phenstatin.[Link](#)

Need Custom Synthesis?

BenchChem offers custom synthesis for rare earth carbides and specific isotopic labeling.

Email: info@benchchem.com or [Request Quote Online](#).

Sources

1. The synthesis and evaluation of new benzophenone derivatives as tubulin polymerization inhibitors - RSC Advances (RSC Publishing) [pubs.rsc.org]
 2. rsc.org [rsc.org]
 3. The synthesis and evaluation of new benzophenone derivatives as tubulin polymerization inhibitors - RSC Advances (RSC Publishing) [pubs.rsc.org]
 4. Benzophenone: a ubiquitous scaffold in medicinal chemistry - MedChemComm (RSC Publishing) [pubs.rsc.org]
 5. Benzophenones-natural metabolites with great Hopes in drug discovery: structures, occurrence, bioactivities, and biosynthesis - RSC Advances (RSC Publishing) DOI:10.1039/D3RA02788K [pubs.rsc.org]
 6. discovery.researcher.life [discovery.researcher.life]
 7. Benzophenone: a ubiquitous scaffold in medicinal chemistry - PMC [pubmed.ncbi.nlm.nih.gov]
 8. pdf.benchchem.com [pdf.benchchem.com]
 9. pdf.benchchem.com [pdf.benchchem.com]
 10. Friedel-Crafts Acylation [www1.udel.edu]
- To cite this document: BenchChem. [Pharmacological Potential of Substituted Benzophenones: A Technical Guide]. BenchChem, [2026]. [Online PDF]. Available at: [<https://www.benchchem.com/product/b1327268#pharmacological-potential-of-substituted-benzophenones>]

Disclaimer & Data Validity:

The information provided in this document is for Research Use Only (RUO) and is strictly not intended for diagnostic or therapeutic procedures. While BenchChem strives to provide accurate protocols, we make no warranties, express or implied, regarding the fitness of this product for every specific experimental setup.

Technical Support: The protocols provided are for reference purposes. Unsure if this reagent suits your experiment? [[Contact our Ph.D. Support Team for a compatibility check](#)]

Need Industrial/Bulk Grade? [Request Custom Synthesis Quote](#)

BenchChem

Our mission is to be the trusted global source of essential and advanced chemicals, empowering scientists and researchers to drive progress in science and industry.

Contact

Address: 3281 E Guasti Rd

Ontario, CA 91761, United States

Phone: (601) 213-4426

Email: info@benchchem.com