

4'-Chloro-2-morpholinomethyl Benzophenone: A Next-Generation Monocomponent Photoinitiator

Author: BenchChem Technical Support Team. **Date:** April 2026

Compound of Interest

Compound Name:	4'-Chloro-2-morpholinomethyl benzophenone
CAS No.:	898750-38-4
Cat. No.:	B1327236

[Get Quote](#)

Executive Summary

The transition from bimolecular to monocomponent photoinitiating systems represents a critical evolutionary leap in photopolymerization technology. Traditional Type II photoinitiators require a secondary amine co-initiator to generate reactive free radicals, introducing severe limitations regarding diffusion kinetics, oxygen inhibition, and the cytotoxicity of leachable amines. **4'-Chloro-2-morpholinomethyl benzophenone** (CAS: 898750-38-4) is engineered to bypass these constraints. By covalently tethering a morpholine electron donor to a halogenated benzophenone chromophore, this molecule achieves ultra-fast intramolecular synergism. This technical guide explores the molecular causality, mechanistic pathways, and self-validating analytical protocols required to harness this compound in advanced materials and biomedical engineering.

Molecular Architecture & Photochemical Causality

Benzophenone (BP) is a ubiquitous Type II photoinitiator. Its mechanism relies on the, converting high-energy photons into an excited state^[1]. However, to initiate polymerization, BP

requires a secondary co-initiator—usually an aliphatic amine—to [2]. This bimolecular collision is statistically inefficient in highly viscous or vitrifying polymer networks.

By synthesizing **4'-Chloro-2-morpholinomethyl benzophenone**, we engineer a [3]. The specific structural modifications serve distinct, causal functions:

- **The Morpholinomethyl Group:** Acts as a built-in hydrogen and electron donor. The spatial proximity of the morpholine nitrogen to the excited carbonyl oxygen guarantees that upon UV excitation, intramolecular electron transfer occurs instantaneously, completely bypassing the diffusion constraints of traditional bimolecular systems.
- **The 4'-Chloro Substituent:** The introduction of a heavy halogen atom at the para position induces a "heavy-atom effect." This facilitates spin-orbit coupling and accelerates Intersystem Crossing (ISC) from the singlet (S1) to the triplet (T1) state, significantly increasing the quantum yield of the reactive triplet species. Furthermore, the electron-withdrawing nature of the chlorine atom red-shifts the absorption spectrum, improving compatibility with modern 365 nm LED curing systems[3].

Mechanism of Action: Intramolecular Synergism

The photophysical cascade of **4'-Chloro-2-morpholinomethyl benzophenone** is a highly efficient intramolecular process.

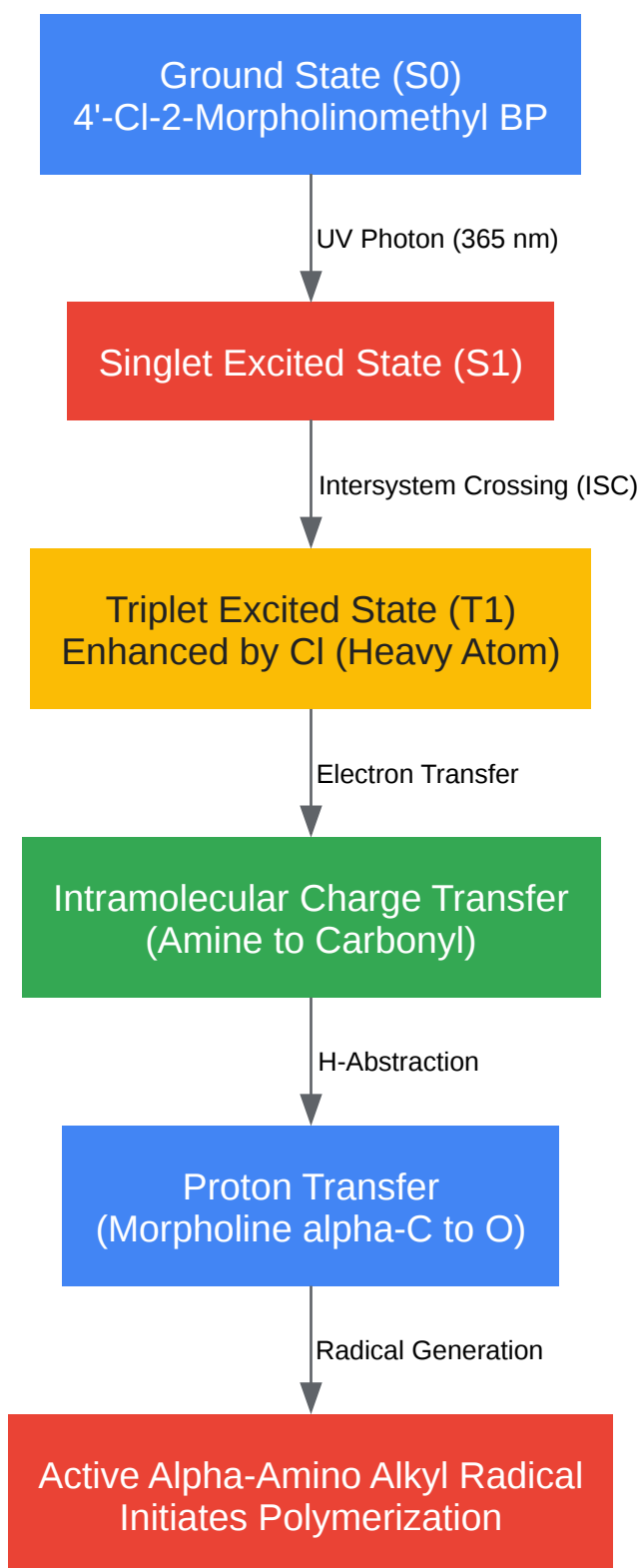

[Click to download full resolution via product page](#)

Mechanism of intramolecular radical generation in **4'-Chloro-2-morpholinomethyl benzophenone**.

Upon UV irradiation, the benzophenone moiety is excited to the S1 state, followed by rapid ISC to the T1 state[2]. In this state, the carbonyl oxygen is highly electrophilic. The nitrogen lone pair of the tethered morpholine group donates an electron, forming an intermediate biradical ion pair. A rapid proton transfer from the morpholine's α -carbon to the ketyl oxygen follows, yielding a highly reactive α -aminoalkyl radical and a relatively stable ketyl radical. The α -aminoalkyl radical acts as the primary initiating species, to propagate the polymer chain[4].

Quantitative Performance Metrics

To contextualize the advantages of this molecular architecture, the table below summarizes the theoretical and practical performance metrics of **4'-Chloro-2-morpholinomethyl benzophenone** against a standard bimolecular benchmark.

Property / Metric	Standard Benzophenone + Amine	4'-Chloro-2-morpholinomethyl BP
System Architecture	Bimolecular (Type II)	Monocomponent (Type II)
Peak Absorption (λ_{max})	~254 nm	~260–320 nm (Broadened)
Initiation Rate Kinetics	Diffusion-limited	Intramolecular (Ultra-fast)
Amine Co-initiator Required	Yes (e.g., TEA, MDEA)	No (Built-in morpholine)
Extractable/Leachable Amines	High Risk	Negligible
Oxygen Inhibition Susceptibility	High	Moderate to Low

Experimental Protocol: Evaluating Kinetics via Photo-DSC Photo-Differential Scanning Calorimetry (Photo-DSC) is the analytical gold standard for quantifying the efficiency of photoinitiators[4]. As a

Senior Application Scientist, I mandate the following self-validating protocol to ensure kinetic data is entirely free from thermal and instrumental artifacts.

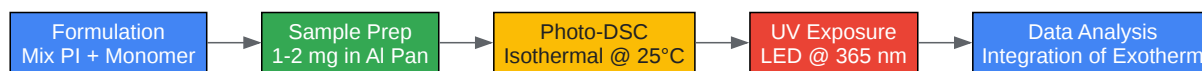

[Click to download full resolution via product page](#)

Standardized Photo-DSC workflow for evaluating photopolymerization kinetics.

Step-by-Step Methodology

Step 1: Resin Formulation Mix 1.5 wt% of the photoinitiator with Tripropyleneglycol diacrylate (TPGDA). Causality: TPGDA is utilized as the model matrix because its low volatility and high difunctionality yield a robust, measurable exotherm without mass-loss artifacts during the highly exothermic curing process[4].

Step 2: Instrument Calibration Calibrate the DSC using an Indium standard under identical purge gas conditions. Causality: Ensures the precise quantification of heat flow (W/g), which is directly proportional to the rate of polymerization.

Step 3: Sample Loading Accurately dispense 1.5–2.0 mg of the formulated resin into an open aluminum pan. Causality: Maintaining a micro-scale sample mass ensures a thin film profile. This eliminates oxygen inhibition gradients and guarantees uniform UV photon penetration throughout the sample volume.

Step 4: Isothermal UV Irradiation Equilibrate the sample at 25°C under a continuous nitrogen purge (50 mL/min). Irradiate using a 365 nm LED at 20 mW/cm². Causality: The nitrogen purge displaces atmospheric oxygen, which would otherwise quench the triplet excited state and scavenge free radicals. Isothermal conditions isolate the chemical heat of reaction from ambient thermal fluctuations.

Step 5: Data Integration & Self-Validation Integrate the exothermic peak to calculate the total heat of polymerization (ΔH_p). Self-Validation: Immediately subject the fully cured sample to a

second, identical UV irradiation cycle. The heat flow recorded during this second run represents the instrumental baseline shift caused by the LED's thermal output. Subtracting this baseline from the initial run ensures that the calculated conversion reflects pure photochemical crosslinking, validating the integrity of the data.

Applications in Advanced Materials & Biomedical Engineering

The elimination of extractable amine co-initiators positions **4'-Chloro-2-morpholinomethyl benzophenone** as a critical enabler in advanced fields:

- **Biomedical Engineering:** In the formulation of hydrogels (e.g., GelMA, PEGDA) for 3D bioprinting and drug delivery, the absence of leachable toxic amines significantly improves cell viability and overall biocompatibility.
- **Advanced Microelectronics:** Monocomponent systems exhibit low migration profiles, preventing outgassing and preserving the dielectric integrity of semiconductor packaging.
- **Food-Safe Packaging:** Reduces the regulatory risks associated with the migration of low-molecular-weight photoinitiator fragments into consumables.

References

- Title: UV Curing: Part Three; Free Radical Photoinitiators Source: Polymer Innovation Blog URL:[[Link](#)]
- Title: Synthesis and photoinitiating behavior of benzophenone-based polymeric photoinitiators used for UV curing coatings Source: ResearchGate URL:[[Link](#)]
- Title: Monocomponent Photoinitiators based on Benzophenone-Carbazole Structure for LED Photoinitiating Systems and Application on 3D Printing Source: MDPI URL:[[Link](#)]

Need Custom Synthesis?

BenchChem offers custom synthesis for rare earth carbides and specific isotopic labeling.

Email: info@benchchem.com or [Request Quote Online](#).

Sources

- [1. Benzophenone UV Absorber: Performance Advantages and Multi-Field Applications - TinToll Performance Materials Co., Ltd. \[uvabsorber.com\]](#)
- [2. UV Curing: Part Three; Free Radical Photoinitiators - Polymer Innovation Blog \[polymerinnovationblog.com\]](#)
- [3. mdpi.com \[mdpi.com\]](#)
- [4. researchgate.net \[researchgate.net\]](#)
- To cite this document: BenchChem. [4'-Chloro-2-morpholinomethyl Benzophenone: A Next-Generation Monocomponent Photoinitiator]. BenchChem, [2026]. [Online PDF]. Available at: [\[https://www.benchchem.com/product/b1327236/docs#4-chloro-2-morpholinomethyl-benzophenone-a-next-generation-monocomponent-photoinitiator\]](https://www.benchchem.com/product/b1327236/docs#4-chloro-2-morpholinomethyl-benzophenone-a-next-generation-monocomponent-photoinitiator)

Disclaimer & Data Validity:

The information provided in this document is for Research Use Only (RUO) and is strictly not intended for diagnostic or therapeutic procedures. While BenchChem strives to provide accurate protocols, we make no warranties, express or implied, regarding the fitness of this product for every specific experimental setup.

Technical Support: The protocols provided are for reference purposes. Unsure if this reagent suits your experiment?

Need Industrial/Bulk Grade? [Request Custom Synthesis Quote](#)

BenchChem

Our mission is to be the trusted global source of essential and advanced chemicals, empowering scientists and researchers to drive progress in science and industry.

Contact

Address: 3281 E Guasti Rd

Ontario, CA 91761, United States

Phone: (601) 213-4426

Email: info@benchchem.com

Contact our Ph.D. Support Team for a compatibility check