

# common problems in pyrazole synthesis and solutions

**Author:** BenchChem Technical Support Team. **Date:** May 2026

## Compound of Interest

Compound Name: *3-(naphthalen-2-yl)-1H-pyrazole*

CAS No.: 150433-20-8

Cat. No.: B1301761

[Get Quote](#)

## Pyrazole Synthesis Technical Support Center

Welcome to the Technical Support Center for Pyrazole Synthesis. This guide is designed for researchers, medicinal chemists, and process development scientists who are navigating the complexities of constructing the pyrazole core. Pyrazoles are a cornerstone in medicinal chemistry and materials science, but their synthesis is not without its challenges. This document provides in-depth, field-proven insights into common problems, presented in a practical question-and-answer format to help you troubleshoot your experiments effectively.

### Section 1: Frequently Asked Questions (FAQs)

#### FAQ 1: What is the most common synthetic route to pyrazoles and what are its primary limitations?

The most classic and widely used method for pyrazole synthesis is the Knorr pyrazole synthesis, which involves the condensation of a 1,3-dicarbonyl compound with a hydrazine derivative.<sup>[1][2][3]</sup> While straightforward, its main limitation is the potential for forming a mixture of regioisomers when an unsymmetrical 1,3-dicarbonyl is reacted with a substituted hydrazine.

[2][4] Traditional methods can also require harsh reaction conditions, such as high temperatures and strong acids, which may not be suitable for complex molecules with sensitive functional groups.[5]

## FAQ 2: My reaction mixture turns a dark yellow or red color. Is this normal and how can I purify my product?

The development of color, typically yellow to red, is a very common observation in pyrazole synthesis, especially when using hydrazine derivatives which can be unstable and prone to side reactions.[6] This discoloration is often due to the formation of minor, highly conjugated impurities.

For purification, several methods can be employed:

- Recrystallization: If your product is a solid, recrystallization is often the first choice.
- Silica Gel Chromatography: This is effective for separating the desired pyrazole from colored impurities and any regioisomers. A common technique is to perform a "plug" filtration where the crude product is passed through a short column of silica gel to remove baseline impurities before a full chromatographic separation.[6]
- Acid Salt Formation: Pyrazoles can be protonated to form salts. By dissolving the crude product in a suitable solvent and adding an acid (like HCl), the pyrazole salt may precipitate in a purer form, leaving colored impurities in the solution. The pure pyrazole can then be recovered by neutralization.[7][8]
- Activated Carbon Treatment: Dissolving the crude product and stirring with a small amount of activated carbon can effectively adsorb colored impurities. Subsequent filtration through celite will yield a decolorized solution from which the product can be isolated.

## FAQ 3: I am not getting the desired pyrazole; instead, I've isolated a pyrazoline. What happened?

This typically occurs when the starting material is an  $\alpha,\beta$ -unsaturated ketone or aldehyde instead of a 1,3-dicarbonyl. The reaction with hydrazine initially forms a pyrazoline via a Michael addition followed by cyclization.[4] Pyrazolines are not aromatic and require a

subsequent oxidation step to be converted to the corresponding pyrazole.[4] If this oxidation step is omitted or is inefficient, you will isolate the pyrazoline intermediate.

## Section 2: Troubleshooting Guide - Regioselectivity in Knorr Pyrazole Synthesis

One of the most persistent challenges in pyrazole synthesis is controlling which nitrogen of a substituted hydrazine attacks which carbonyl of an unsymmetrical 1,3-dicarbonyl, leading to two possible regioisomers.

### Question: I am getting a mixture of regioisomers in my Knorr pyrazole synthesis. How can I improve the selectivity for my desired product?

Answer: Achieving high regioselectivity is a multi-faceted problem that can be addressed by carefully tuning the reaction conditions. The outcome is governed by a delicate balance of steric and electronic factors of the substrates, as well as solvent and catalyst effects.

The reaction proceeds through the formation of a hydrazone intermediate. The initial nucleophilic attack of one of the hydrazine's nitrogen atoms on one of the carbonyl groups dictates the final regiochemistry. The more nucleophilic nitrogen will preferentially attack the more electrophilic (and less sterically hindered) carbonyl carbon.[2][3]

The following diagram illustrates the two competing pathways:

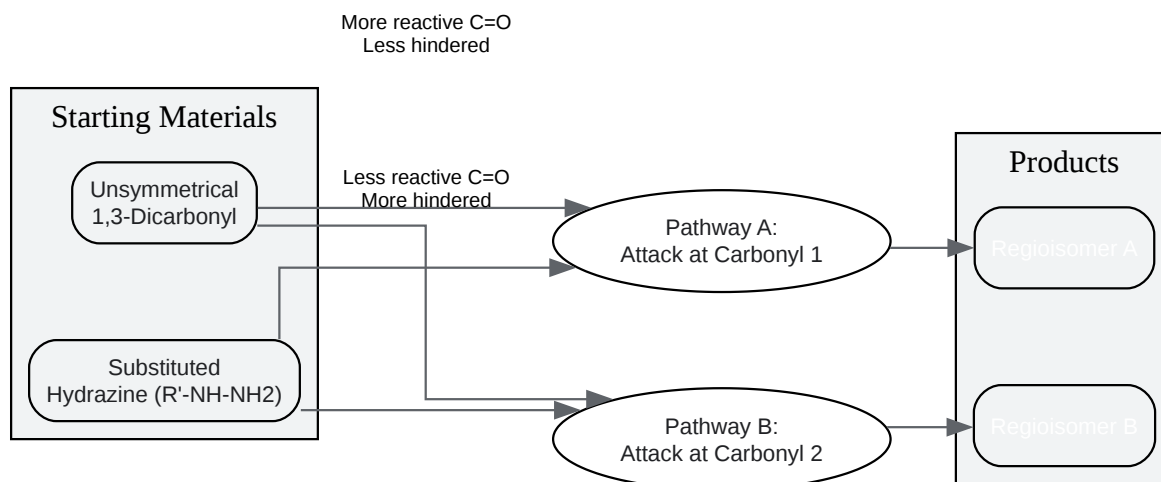

[Click to download full resolution via product page](#)

Caption: Competing pathways in Knorr synthesis leading to regioisomers.

Here are several strategies to enhance regioselectivity, ranging from simple solvent changes to more advanced catalytic systems.

### 1. Solvent Modification:

The solvent can significantly influence the reaction's regioselectivity by stabilizing intermediates or altering the nucleophilicity of the hydrazine.

- **Insight:** Standard solvents like ethanol often lead to poor selectivity.[6] Aprotic dipolar solvents such as N,N-dimethylacetamide (DMAc) can improve selectivity.[2]
- **Protocol:** Recent studies have shown that fluorinated alcohols, such as 2,2,2-trifluoroethanol (TFE) and 1,1,1,3,3,3-hexafluoro-2-propanol (HFIP), can dramatically increase regioselectivity.[6] These solvents can stabilize key intermediates through hydrogen bonding, directing the reaction down a specific pathway.

| Solvent                      | Typical Regioisomeric Ratio (Desired:Undesired) | Reference |
|------------------------------|---|-----------|
| Ethanol                      | Often poor (e.g., 1:1 to 3:1)                   | [2][6]    |
| N,N-Dimethylacetamide (DMAc) | Good (e.g., >98:2 reported in some cases)       | [2]       |
| 2,2,2-Trifluoroethanol (TFE) | Excellent (Often leads to a single isomer)      | [6]       |

## 2. pH Control:

The pH of the reaction medium affects the protonation state of the hydrazine and the enolization of the dicarbonyl, thereby influencing which pathway is favored.

- Insight: The reaction is typically acid-catalyzed.[1] By carefully selecting the acid and its concentration, you can modulate the reactivity of the carbonyl groups.
- Experimental Workflow:

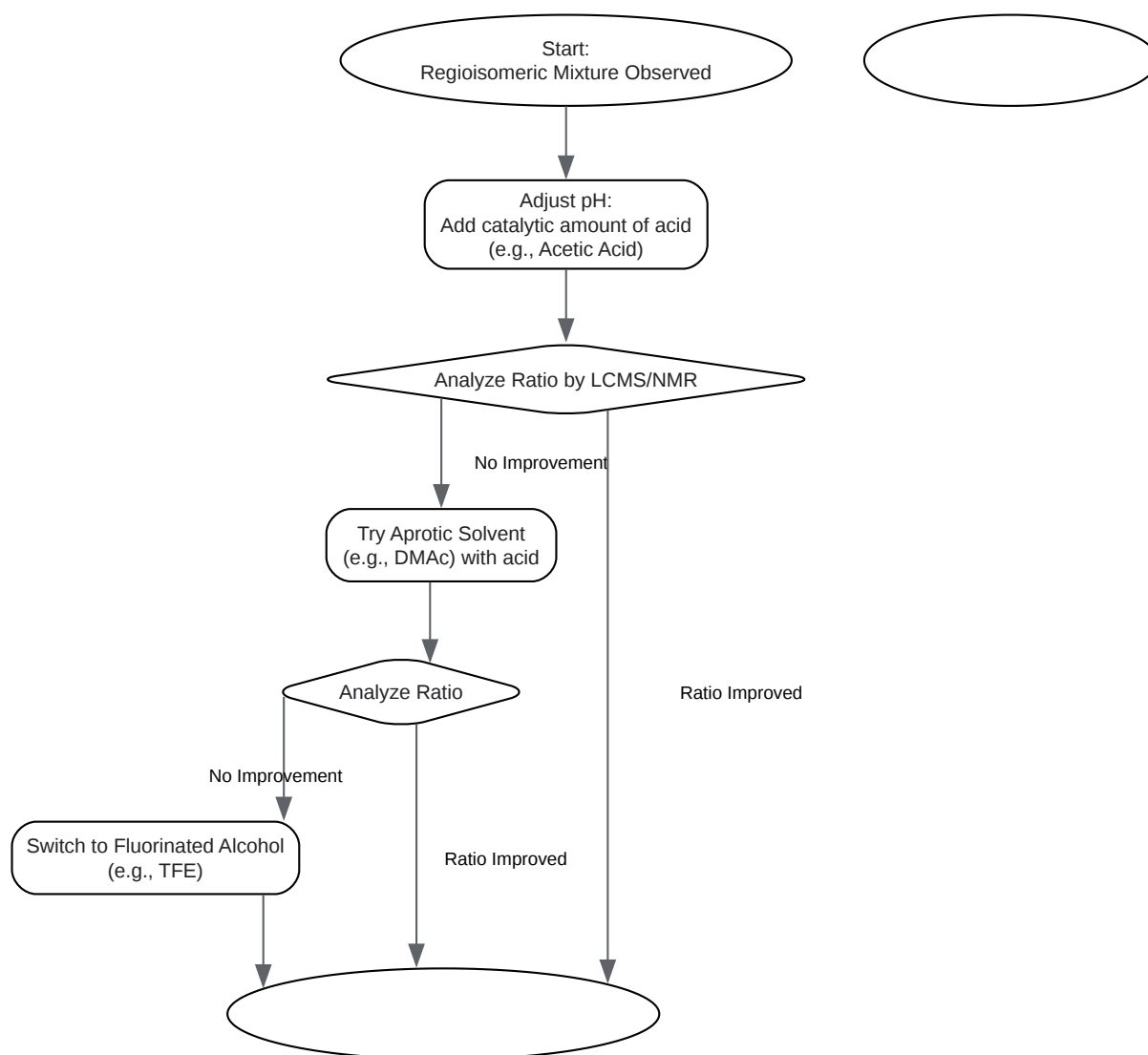

[Click to download full resolution via product page](#)

Caption: Troubleshooting workflow for improving regioselectivity.

### 3. Alternative Synthetic Strategies:

If modifying the Knorr conditions is unsuccessful, consider alternative methods that offer inherent regiocontrol.

- Insight: Syntheses that do not rely on the direct condensation of an unsymmetrical 1,3-dicarbonyl can bypass the regioselectivity issue.
- Example Protocol (from Hydrazones and Nitroolefins): A regioselective synthesis of 1,3,5-trisubstituted pyrazoles can be achieved by reacting N-arylhydrazones with nitroolefins. This method leverages the difference in nucleophilicity between the nitrogen and carbon atoms of the hydrazone for excellent regiocontrol.[9]

Step-by-Step Methodology:

- Dissolve the N-arylhydrazone (1.0 eq) and the nitroolefin (1.1 eq) in ethylene glycol.
- Heat the mixture at 120 °C for 2-4 hours, monitoring by TLC.
- For less reactive, electron-deficient hydrazones, a more effective protocol involves using 2,2,2-trifluoroethanol (TFE) as the solvent with a catalytic amount of trifluoroacetic acid (TFA) at 80 °C.[9]
- Upon completion, cool the reaction, dilute with water, and extract the product with an organic solvent (e.g., ethyl acetate).
- Purify by column chromatography.

## Section 3: Troubleshooting Guide - Side Reactions and Purification

**Question: My pyrazole synthesis from an  $\alpha,\beta$ -unsaturated ketone is low-yielding and I have a major byproduct. How do I improve the yield and identify the byproduct?**

Answer: The most common issue in this synthesis is the incomplete oxidation of the intermediate pyrazoline to the final pyrazole. The byproduct is very likely the pyrazoline itself.

## 1. In-Situ Oxidation:

- Insight: Performing the cyclization and oxidation in one pot is often more efficient and can lead to higher yields.
- Protocol 1 (Iodine-mediated):
  - Dissolve the  $\alpha,\beta$ -unsaturated ketone (1.0 eq) and the hydrazine derivative (1.2 eq) in acetic acid.
  - Add iodine (1.0 eq) to the mixture.
  - Stir at room temperature or heat gently (e.g., 50-60 °C) until the starting material is consumed (monitor by TLC).
  - Work up by quenching with aqueous sodium thiosulfate solution to remove excess iodine, followed by extraction.
- Protocol 2 (Air/DMSO Oxidation):
  - Condense the  $\alpha,\beta$ -unsaturated ketone and hydrazine in a suitable solvent to form the pyrazoline.
  - After the initial reaction, switch the solvent to DMSO.
  - Heat the solution in an open flask (to allow contact with air) to facilitate oxidation.<sup>[10]</sup> This is a greener alternative to using stoichiometric oxidants.

## 2. Characterization of Byproduct:

You can confirm the identity of the byproduct as the pyrazoline using standard analytical techniques:

- $^1\text{H}$  NMR: The pyrazoline will show aliphatic protons in the 2.5-5.0 ppm range corresponding to the CH and CH<sub>2</sub> groups of the non-aromatic ring. These signals will be absent in the aromatic pyrazole product.

- Mass Spectrometry: The pyrazoline will have a molecular weight that is 2 Da higher than the corresponding pyrazole.

## References

- Deng, X., & Mani, N. S. (2008). Regioselective Synthesis of 1,3,5-Tri- and 1,3,4,5-Tetrasubstituted Pyrazoles from N-Arylhydrazones and Nitroolefins. *The Journal of Organic Chemistry*, 73(6), 2412–2415. [[Link](#)]
- Knorr Pyrazole Synthesis (M. Pharm). (2018). Slideshare. [[Link](#)]
- Katritzky, A. R., et al. (2002). Regioselective Synthesis of Polysubstituted Pyrazoles and Isoxazoles. *The Journal of Organic Chemistry*, 67(23), 8224–8229. [[Link](#)]
- Process for the purification of pyrazoles. (2011).
- Knorr Pyrazole Synthesis. Chem Help Asap. [[Link](#)]
- López-Alvarado, P., et al. (2012). Improved Regioselectivity in Pyrazole Formation through the Use of Fluorinated Alcohols as Solvents: Synthesis and Biological Activity of Fluorinated Tebufenpyrad Analogs. *The Journal of Organic Chemistry*, 77(17), 7383–7393. [[Link](#)]
- Valdés, C. M., et al. (2022). Recent Advances in Synthesis and Properties of Pyrazoles. *Molecules*, 27(19), 6536. [[Link](#)]
- Pyrazole synthesis. Organic Chemistry Portal. [[Link](#)]
- Kumar, V., et al. (2024). Recent advances in the multicomponent synthesis of pyrazoles. *Organic & Biomolecular Chemistry*. [[Link](#)]
- Dömling, A., et al. (2024). Multicomponent syntheses of pyrazoles via (3 + 2)-cyclocondensation and (3 + 2)-cycloaddition key steps. *Beilstein Journal of Organic Chemistry*, 20, 178-223. [[Link](#)]
- Faria, J. V., et al. (2023). Recent Advances in the Synthesis of Pyrazole Derivatives: A Review. *Molecules*, 28(18), 6580. [[Link](#)]

- El-Faham, A., et al. (2021). Synthesis and Pharmacological Activities of Pyrazole Derivatives: A Review. *Molecules*, 26(24), 7429. [[Link](#)]
- Sharma, V., et al. (2020). A regioselective synthesis of 3,4-diaryl-1H-pyrazoles through a 1,3-dipolar cycloaddition of tosylhydrazones and nitroalkenes. *Organic & Biomolecular Chemistry*, 18(34), 6649-6653. [[Link](#)]
- Knorr Pyrazole Synthesis. J&K Scientific LLC. [[Link](#)]

### Need Custom Synthesis?

BenchChem offers custom synthesis for rare earth carbides and specific isotopic labeling.

Email: [info@benchchem.com](mailto:info@benchchem.com) or [Request Quote Online](#).

## Sources

1. Knorr Pyrazole Synthesis (M. Pharm) | PPTX [[slideshare.net](#)]
  2. Synthesis and Pharmacological Activities of Pyrazole Derivatives: A Review - PMC [[pmc.ncbi.nlm.nih.gov](#)]
  3. [jk-sci.com](#) [[jk-sci.com](#)]
  4. [mdpi.com](#) [[mdpi.com](#)]
  5. [mdpi.com](#) [[mdpi.com](#)]
  6. [pubs.acs.org](#) [[pubs.acs.org](#)]
  7. DE102009060150A1 - Process for the purification of pyrazoles - Google Patents [[patents.google.com](#)]
  8. WO2011076194A1 - Method for purifying pyrazoles - Google Patents [[patents.google.com](#)]
  9. Regioselective Synthesis of 1,3,5-Tri- and 1,3,4,5-Tetrasubstituted Pyrazoles from N-Arylhydrazones and Nitroolefins [[organic-chemistry.org](#)]
  10. Pyrazole synthesis [[organic-chemistry.org](#)]
- To cite this document: BenchChem. [common problems in pyrazole synthesis and solutions]. BenchChem, [2026]. [Online PDF]. Available at: [<https://www.benchchem.com/product/b1301761/docs#common-problems-in-pyrazole-synthesis-and-solutions>]

**Disclaimer & Data Validity:**

The information provided in this document is for Research Use Only (RUO) and is strictly not intended for diagnostic or therapeutic procedures. While BenchChem strives to provide accurate protocols, we make no warranties, express or implied, regarding the fitness of this product for every specific experimental setup.

**Technical Support:** The protocols provided are for reference purposes. Unsure if this reagent suits your experiment?

**Need Industrial/Bulk Grade?** [Request Custom Synthesis Quote](#)

## BenchChem

Our mission is to be the trusted global source of essential and advanced chemicals, empowering scientists and researchers to drive progress in science and industry.

### Contact

Address: 3281 E Guasti Rd  
Ontario, CA 91761, United States  
Phone: (601) 213-4426  
Email: [info@benchchem.com](mailto:info@benchchem.com)

[Contact our Ph.D. Support Team for a compatibility check](#)