

Technical Support Center: Preventing Thiophene Oxidation & Polymerization

Author: BenchChem Technical Support Team. **Date:** April 2026

Compound of Interest

Compound Name: *3-Methyl-2-(5-methylthiophen-3-yl)butanoic acid*

Cat. No.: B13254203

[Get Quote](#)

Topic: Stability of Thiophene Rings During Acid Hydrolysis

Diagnostic & Triage: The "Black Tar" Scenario

User Report: "I attempted to hydrolyze a thiophene-carboxylate ester using 6N HCl at reflux. Within 20 minutes, the reaction turned from pale yellow to dark red, then eventually resulted in a black, insoluble tar. My product is gone."

Root Cause Analysis: You have encountered the Acid-Catalyzed Oxidative Polymerization of thiophene. Unlike benzene, thiophene is an electron-rich heterocycle (

electrons over 5 atoms). In the presence of strong acids and trace oxidants (dissolved oxygen, metal ions, or the acid itself), two catastrophic pathways activate:

- Electrophilic Polymerization: Protonation generates a reactive cation that attacks neutral thiophene rings, leading to polythiophene chains (the "Black Tar").

- S-Oxidation: Formation of thiophene-S-oxide, which is highly unstable and dimerizes or decomposes.

Decision Matrix: Selecting the Safe Hydrolysis Route

Before proceeding with a rescue protocol, determine if acid hydrolysis is strictly necessary. Use this logic flow to select the safest methodology.

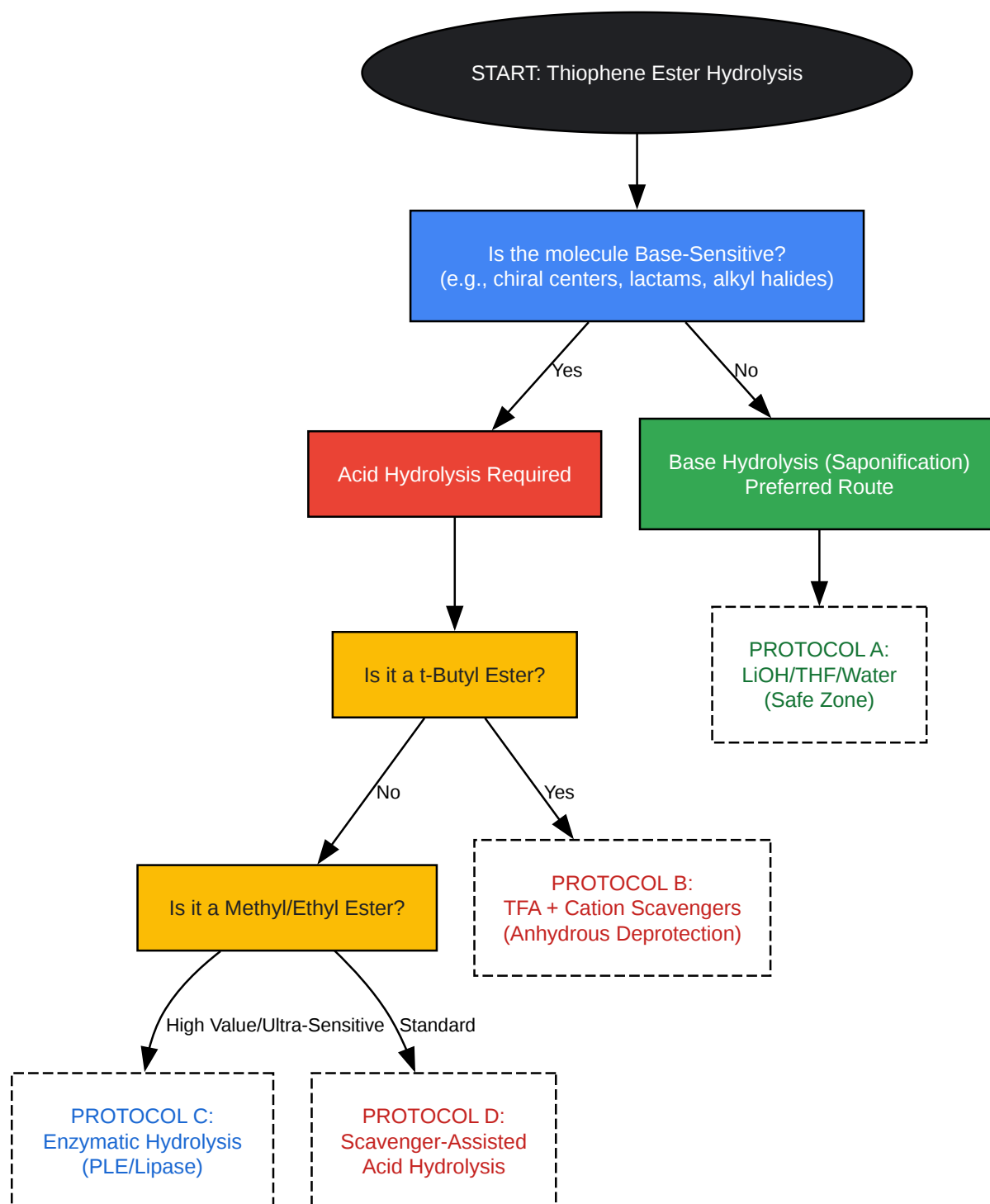

[Click to download full resolution via product page](#)

Figure 1: Decision matrix for hydrolyzing thiophene esters. Acid hydrolysis (Red/Orange paths) requires strict scavenger protocols.

Technical Deep Dive: The Mechanism of Failure

To prevent degradation, you must understand the invisible enemy. The diagram below illustrates the competing pathways during acid exposure.

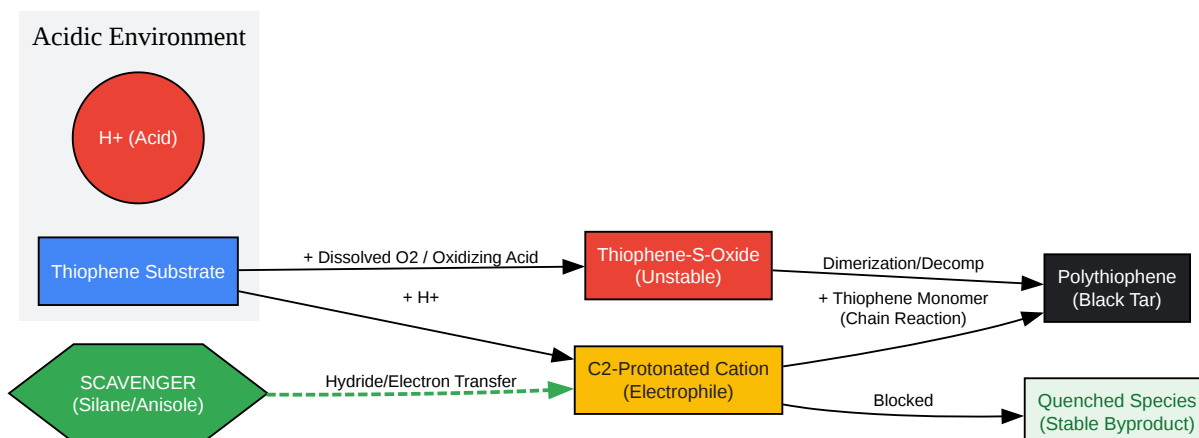

[Click to download full resolution via product page](#)

Figure 2: Mechanistic pathway of degradation. Scavengers (Green) intercept the reactive cation intermediate before it can initiate polymerization.

Troubleshooting FAQs

Q1: Why can't I use Nitric Acid or concentrated Sulfuric Acid? A: These are oxidizing acids.

- Sulfuric Acid (): At high concentrations or temperatures, it acts as an oxidant, causing rapid S-oxidation and sulfonation of the ring.
- Nitric Acid (): Will nitrate the ring (explosively fast on electron-rich thiophenes) or oxidatively cleave it.
- Solution: Use non-oxidizing mineral acids like HCl (Hydrochloric) or

(Phosphoric), or organic acids like TFA (Trifluoroacetic acid).

Q2: What is the "Pink/Red" color indicating? A: This is the "Canary in the Coal Mine."

- The red shift indicates the formation of oligomers (short chains of 2-3 thiophene units).
- Immediate Action: Dilute the reaction mixture with cold solvent (DCM or Ethyl Acetate) immediately to stop the polymerization chain reaction.

Q3: Which scavenger should I use? A: Scavengers act as "cation sinks." They react with the electrophilic species faster than the thiophene ring does.

Scavenger	Type	Best For	Notes
Triethylsilane (TES)	Hydride Donor	TFA Deprotections	Excellent for t-butyl cleavage. Volatile and easy to remove.
Anisole / Phenol	Electron-Rich Arene	Strong Acid Hydrolysis	Traps cations via Friedel-Crafts alkylation. Harder to remove.
Ethanethiol / DODT	Nucleophile	S-protection	Good for preventing S-oxidation, but smells terrible.
Ascorbic Acid	Antioxidant	Aqueous Hydrolysis	Prevents radical-mediated oxidation in aqueous HCl.

Validated Protocols

Protocol A: The "Safe Acid" Hydrolysis (Aqueous)

Use this for methyl/ethyl esters when base hydrolysis is impossible.

Reagents:

- Substrate (1 equiv)

- 1,4-Dioxane (Solvent - miscible with water, good solubility)
- 4N HCl (Aqueous)
- Additive: Ascorbic Acid (0.1 equiv) or BHT (Trace)

Procedure:

- Degas Solvents: Sparge the 1,4-Dioxane and 4N HCl with Nitrogen or Argon for 15 minutes. This removes dissolved oxygen, the primary initiator of S-oxidation.
- Dissolve substrate in Dioxane under inert atmosphere.
- Add Ascorbic Acid (Antioxidant).
- Add degassed 4N HCl dropwise.
- Heat to maximum 60°C. Do not reflux. Monitor by TLC/LCMS every 30 mins.
- Workup: Neutralize with saturated
immediately upon completion. Do not let it sit in acid.

Protocol B: The "Scavenger Cocktail" (Anhydrous Deprotection)

Use this for cleaving t-butyl esters or acid-labile protecting groups.

Reagents:

- TFA (Trifluoroacetic Acid)
- DCM (Dichloromethane)
- Scavenger: Triethylsilane (TES)

Procedure:

- Prepare a solution of TFA:DCM:TES (Ratio 50:45:5).

- Cool the solution to 0°C.
- Add the thiophene substrate.[\[1\]](#)[\[2\]](#)[\[3\]](#)
- Warm to room temperature and stir.
- Mechanism: The t-butyl cation generated is immediately quenched by TES (forming isobutane and silyl species), preventing it from attacking the thiophene ring.

Protocol C: The "Nuclear Option" (Enzymatic)

Use this if the thiophene ring decomposes even under mild acid conditions.

Reagents:

- Pig Liver Esterase (PLE) or *Candida antarctica* Lipase B (CAL-B).
- Phosphate Buffer (pH 7.0).
- Acetone (Co-solvent, <10%).

Procedure:

- Suspend ester in Buffer/Acetone.
- Add Enzyme (10-50 mg/mmol).
- Stir at 30°C.
- Monitor pH and add dilute NaOH to maintain pH 7.0 (pH-stat titration).
- Result: Hydrolysis occurs at neutral pH with zero risk of oxidation or polymerization.

References

- Dansette, P. M., et al. (2002). "Mechanism of the Aromatic Hydroxylation of Thiophene by Acid-Catalyzed Peracid Oxidation." *Journal of Organic Chemistry*. [Link](#)

- BenchChem. (2025).[1] "3-Acetylthiophene: A Technical Guide to Stability and Reactivity." BenchChem Technical Library. [Link](#)
- Søndergaard, R., et al. (2011). "Low-temperature side-chain cleavage and decarboxylation of polythiophene esters by acid catalysis." Journal of Polymer Science Part A: Polymer Chemistry. [Link](#)
- Supra Sciences. (n.d.). "Solid-Supported Scavengers for Acidic Protocols." Supra Sciences Technical Guides. [Link](#)
- RSC Publishing. (2012). "A novel route for polymerisation of thiophene based conducting polymers using trace-free oxidants." Polymer Chemistry. [Link](#)

Need Custom Synthesis?

BenchChem offers custom synthesis for rare earth carbides and specific isotopic labeling.

Email: info@benchchem.com or [Request Quote Online](#).

Sources

- [1. pdf.benchchem.com \[pdf.benchchem.com\]](https://pdf.benchchem.com)
- [2. US4051151A - Thiophene derivatives and process for preparation thereof - Google Patents \[patents.google.com\]](https://patents.google.com)
- [3. Recent developments in the synthesis of regioregular thiophene-based conjugated polymers for electronic and optoelectronic applications using nickel and palladium-based catalytic systems - PMC \[pmc.ncbi.nlm.nih.gov\]](https://pubmed.ncbi.nlm.nih.gov)
- To cite this document: BenchChem. [Technical Support Center: Preventing Thiophene Oxidation & Polymerization]. BenchChem, [2026]. [Online PDF]. Available at: [\[https://www.benchchem.com/product/b13254203/docs#technical-support-center-preventing-thiophene-oxidation-polymerization\]](https://www.benchchem.com/product/b13254203/docs#technical-support-center-preventing-thiophene-oxidation-polymerization)

Disclaimer & Data Validity:

The information provided in this document is for Research Use Only (RUO) and is strictly not intended for diagnostic or therapeutic procedures. While BenchChem strives to provide

accurate protocols, we make no warranties, express or implied, regarding the fitness of this product for every specific experimental setup.

Technical Support: The protocols provided are for reference purposes. Unsure if this reagent suits your experiment?

Need Industrial/Bulk Grade? [Request Custom Synthesis Quote](#)

BenchChem

Our mission is to be the trusted global source of essential and advanced chemicals, empowering scientists and researchers to drive progress in science and industry.

Contact

Address: 3281 E Guasti Rd

Ontario, CA 91761, United States

Phone: (601) 213-4426

Email: info@benchchem.com

[Contact our Ph.D. Support Team for a compatibility check](#)