

# Next-Generation Synthesis of Substituted Benzophenones: Beyond Friedel-Crafts

**Author:** BenchChem Technical Support Team. **Date:** April 2026

## Compound of Interest

*Compound Name:* 3,5-Difluoro-3'-morpholinomethyl  
benzophenone

*CAS No.:* 898792-32-0

*Cat. No.:* B1325646

[Get Quote](#)

## Executive Summary

The benzophenone scaffold is a privileged pharmacophore in medicinal chemistry, serving as the core structure for non-steroidal anti-inflammatory drugs (e.g., Ketoprofen), UV blockers (e.g., Oxybenzone), and antimicrobial agents. Historically, the Friedel-Crafts acylation has been the industrial workhorse for their synthesis. However, its reliance on stoichiometric Lewis acids ( $\text{AlCl}_3$ ), moisture sensitivity, and poor regioselectivity on electron-deficient arenes renders it suboptimal for modern drug discovery.

This technical guide delineates three high-fidelity, novel synthetic routes that circumvent these limitations: Palladium-Catalyzed Carbonylative Cross-Coupling, Rhodium(III)-Catalyzed C-H Activation, and Transition-Metal-Free Decarbonyl-Oxidation.

## The New Gold Standard: Palladium-Catalyzed Carbonylative Suzuki-Miyaura Coupling

The most versatile modern approach is the insertion of carbon monoxide (CO) between an aryl halide and an aryl boronic acid. This method offers superior functional group tolerance compared to Friedel-Crafts.

## The Safety Paradigm: CO Surrogates

Handling gaseous CO is hazardous and requires high-pressure reactors. The current state-of-the-art utilizes CO surrogates—solid or liquid reagents that release CO in situ under catalytic conditions.

- TFBen (Benzene-1,3,5-triyl triformate): A solid precursor that releases CO upon base activation.
- Mo(CO)<sub>6</sub>: A metal carbonyl that releases CO upon heating.
- DMF: Can serve as a CO source under specific oxidative conditions, though less atom-economical.

## Mechanistic Pathway

The reaction proceeds via a modified Pd(0)/Pd(II) cycle:

- Oxidative Addition: Pd(0) inserts into the Ar-X bond.
- CO Insertion: CO coordinates and inserts to form an acyl-palladium species. Critical Control Point: High CO pressure can inhibit the reaction by saturating the metal center; surrogates mitigate this by slow release.
- Transmetalation: The aryl boronic acid transfers its aryl group to the palladium center.
- Reductive Elimination: The benzophenone is released, regenerating Pd(0).

## Atom Economy via Rhodium(III)-Catalyzed C-H Activation

While cross-coupling is robust, it requires pre-functionalized starting materials (halides and boronic acids). C-H activation offers a more direct route by functionalizing ubiquitously available C-H bonds.

## The Directing Group (DG) Strategy

To achieve regioselectivity without halides, a Directing Group (e.g., amide, ketone, or oxime) coordinates to the Rh(III) center, bringing the metal into proximity with the ortho-C-H bond.

- Catalyst:  $[\text{Cp}^*\text{RhCl}_2]_2$  is the precatalyst of choice.
- Coupling Partners: Aryl aldehydes (oxidative acylation) or -keto acids (decarboxylative acylation).
- Mechanism: The cycle involves C-H bond cleavage via Concerted Metalation-Deprotonation (CMD), followed by insertion of the coupling partner and reductive elimination.

## Comparative Analysis of Synthetic Routes

Feature	Friedel-Crafts (Legacy)	Pd-Carbonylative Suzuki (Novel)	Rh(III) C-H Activation (Novel)
Regioselectivity	Substrate controlled (often poor)	Excellent (determined by leaving group)	Excellent (determined by DG)
FG Tolerance	Low (Acid sensitive groups fail)	High (Esters, nitriles, amines tolerated)	Moderate (Requires DG)
Atom Economy	Low (Stoichiometric $\text{AlCl}_3$ waste)	Moderate (Boronic acid waste)	High (Direct C-H functionalization)
Safety Profile	Corrosive reagents	High (If using solid CO surrogates)	High (No CO gas)
Key Limitation	Isomer mixtures	Cost of Pd/Ligands	Cost of Rh; DG removal steps

## Experimental Protocol: Carbonylative Suzuki Coupling using TFBen

Objective: Synthesis of 4-methoxy-4'-nitrobenzophenone. Rationale: Demonstrates the coupling of an electron-rich boronic acid with an electron-deficient aryl halide—a transformation difficult to achieve selectively via Friedel-Crafts.

## Materials

- Aryl Halide: 1-iodo-4-nitrobenzene (1.0 mmol)
- Nucleophile: 4-methoxyphenylboronic acid (1.2 mmol)
- CO Surrogate: TFBen (0.4 mmol, releases 1.2 eq CO)
- Catalyst: Pd(OAc)<sub>2</sub> (2 mol%)[1]
- Ligand: Xantphos (3 mol%) - Selected for its large bite angle, which stabilizes the acyl-palladium intermediate.
- Base: Et<sub>3</sub>N (2.0 equiv)
- Solvent: 1,4-Dioxane (dry, 5 mL)

## Step-by-Step Methodology

- Setup: In a glovebox or under a steady stream of Argon, charge a dried reaction tube with Pd(OAc)<sub>2</sub>, Xantphos, TFBen, aryl iodide, and aryl boronic acid.
- Solvation: Add 1,4-Dioxane and Et<sub>3</sub>N via syringe. Seal the tube immediately.
- Activation: Place the reaction vessel in a pre-heated oil bath at 80°C.
  - Note: TFBen decomposes to release CO at this temperature. Do not overheat (>100°C) initially to prevent over-pressurization.
- Monitoring: Stir for 12 hours. Monitor via TLC (Eluent: Hexane/EtOAc 8:1). Look for the disappearance of the aryl iodide.
- Workup: Cool to room temperature. Dilute with Ethyl Acetate (20 mL) and wash with water (2 x 10 mL) and brine (10 mL).
- Purification: Dry organic layer over Na<sub>2</sub>SO<sub>4</sub>, concentrate in vacuo. Purify via flash column chromatography on silica gel.

## Visualizations

## Palladium Catalytic Cycle (Carbonylative Suzuki)

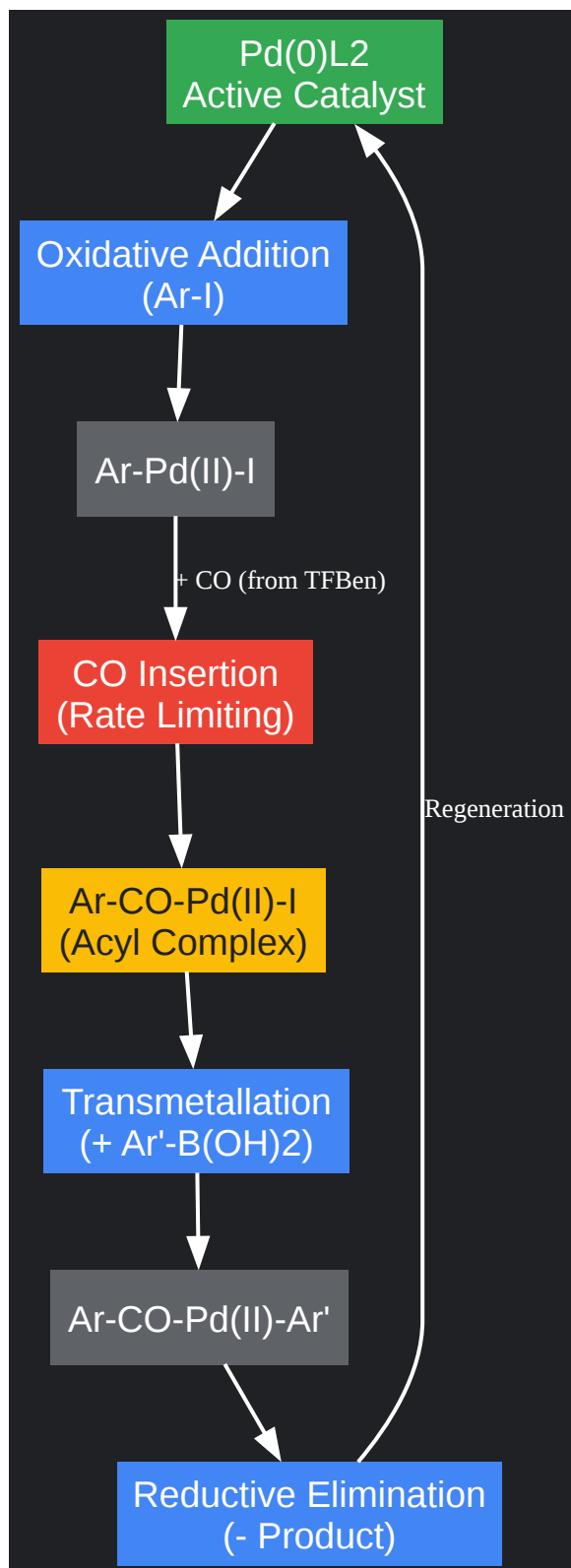

[Click to download full resolution via product page](#)

Figure 1: The catalytic cycle for Pd-catalyzed carbonylative coupling.[2] Note the critical CO insertion step occurring prior to transmetalation.

## Experimental Workflow (TFBen Protocol)



[Click to download full resolution via product page](#)

Figure 2: Operational workflow for the synthesis of benzophenones using solid CO surrogates.

## References

- Beilstein J. Org. Chem. (2024).[3] Transition-metal-free decarbonyl-oxidation of 3-arylbenzofuran-2(3H)-ones: access to 2-hydroxybenzophenones. [[Link](#)]
- RSC Advances (2024). Synthesis and bioactivity investigation of benzophenone and its derivatives. [[Link](#)]
- Chem. Soc. Rev. (2024). Recent advances in Rh(I)-catalyzed enantioselective C–H functionalization. [[Link](#)]
- Catalysts (2021). DMF as CO Surrogate in Carbonylation Reactions: Principles and Application to the Synthesis of Heterocycles. [[Link](#)][4][5]
- Green Chem. (2021). An efficient protocol for the palladium-catalysed Suzuki–Miyaura cross-coupling. [[Link](#)]

### Need Custom Synthesis?

BenchChem offers custom synthesis for rare earth carbides and specific isotopic labeling.

Email: [info@benchchem.com](mailto:info@benchchem.com) or [Request Quote Online](#).

## Sources

- [1. researchgate.net \[researchgate.net\]](#)
- [2. eprints.whiterose.ac.uk \[eprints.whiterose.ac.uk\]](#)
- [3. Recent advances in Rh\( i \)-catalyzed enantioselective C–H functionalization - Chemical Society Reviews \(RSC Publishing\) DOI:10.1039/D3CS00762F \[pubs.rsc.org\]](#)
- [4. mdpi.com \[mdpi.com\]](#)
- [5. arpi.unipi.it \[arpi.unipi.it\]](#)
- To cite this document: BenchChem. [Next-Generation Synthesis of Substituted Benzophenones: Beyond Friedel-Crafts]. BenchChem, [2026]. [Online PDF]. Available at: [\[https://www.benchchem.com/product/b1325646/docs#next-generation-synthesis-of-substituted-benzophenones-beyond-friedel-crafts\]](https://www.benchchem.com/product/b1325646/docs#next-generation-synthesis-of-substituted-benzophenones-beyond-friedel-crafts)

---

### Disclaimer & Data Validity:

The information provided in this document is for Research Use Only (RUO) and is strictly not intended for diagnostic or therapeutic procedures. While BenchChem strives to provide accurate protocols, we make no warranties, express or implied, regarding the fitness of this product for every specific experimental setup.

**Technical Support:** The protocols provided are for reference purposes. Unsure if this reagent suits your experiment?

**Need Industrial/Bulk Grade?** [Request Custom Synthesis Quote](#)

## BenchChem

Our mission is to be the trusted global source of essential and advanced chemicals, empowering scientists and researchers to drive progress in science and industry.

### Contact

Address: 3281 E Guasti Rd

Ontario, CA 91761, United States

Phone: (601) 213-4426

Email: [info@benchchem.com](mailto:info@benchchem.com)

Contact our Ph.D. Support Team for a compatibility check