

Comparative Docking Guide: Isoindoline Ligands in Drug Discovery

Author: BenchChem Technical Support Team. **Date:** April 2026

Compound of Interest

Compound Name: *1-(2,3-dihydro-1H-isoindol-1-yl)ethan-1-ol*
Cat. No.: B13247629

[Get Quote](#)

Executive Summary

This guide provides a technical comparison of isoindoline-based ligands (specifically isoindoline-1,3-dione and isoindolin-1-one scaffolds) against standard therapeutic agents. Isoindolines are "privileged scaffolds" in medicinal chemistry due to their ability to participate in diverse non-covalent interactions—primarily

stacking and hydrogen bonding via the imide/lactam functionality.

This document focuses on two critical therapeutic areas where isoindolines have demonstrated competitive performance: Neurodegeneration (AChE Inhibitors) and Inflammation (COX-2 Inhibitors).

Part 1: Core Protocol & Methodological Rigor

To ensure Trustworthiness and Reproducibility, docking studies involving isoindolines must address the specific electronic and steric properties of the bicyclic ring system.

Ligand Preparation Strategy

- Tautomeric States: Isoindoline-1,3-diones (phthalimides) are generally stable, but isoindolin-1-ones may exhibit lactam-lactim tautomerism. Directive: Always generate 3D conformers at pH 7.4 (physiological) to determine the dominant tautomer before docking.
- Ring Planarity: The benzene ring fused to the pyrroline-dione creates a rigid planar core.
 - Causality: This rigidity reduces the entropic penalty upon binding but requires precise active site fitting.
 - Action: Use DFT (B3LYP/6-31G*) optimization for the ligand core to ensure accurate bond angles before import into docking software.

Target Selection & Preparation

- Water Molecules:
 - AChE: Conserved water molecules bridging the Peripheral Anionic Site (PAS) are critical. Do not remove all waters blindly.
 - COX-2:[\[1\]](#)[\[2\]](#)[\[3\]](#)[\[4\]](#) The active site is a hydrophobic channel. Removal of waters is generally acceptable, but check for waters coordinating with Arg120.
- Grid Box Definition:
 - Center the grid on the co-crystallized ligand (e.g., Donepezil for AChE, Celecoxib for COX-2).
 - Dimension: Extend the grid by 5–8 Å beyond the ligand to accommodate bulky N-substituents typical of isoindoline derivatives.

Validation Metric (Self-Validating System)

Before docking new derivatives, you must re-dock the native co-crystallized ligand.

- Acceptance Criteria: Root Mean Square Deviation (RMSD)

2.0 Å between the docked pose and the crystal pose.

- Failure Mode: If RMSD > 2.0 Å, recalibrate the force field (e.g., switch from MMFF94 to OPLS3e) or adjust the grid box size.

Part 2: Comparative Case Studies

Case Study A: Acetylcholinesterase (AChE) Inhibition (Alzheimer's)

Objective: Compare N-substituted isoindoline-1,3-diones against Donepezil.

1. Mechanistic Rationale

AChE contains a deep gorge with two binding sites: the Catalytic Anionic Site (CAS) at the bottom and the Peripheral Anionic Site (PAS) at the entrance.

- Donepezil: Spans the gorge, interacting with both sites.
- Isoindolines: Designed with flexible linkers (e.g., ethyl-piperazine chains) to mimic this "dual-binding" mode. The isoindoline ring typically targets the PAS (Trp279) via
-
stacking, while the N-substituent reaches the CAS.

2. Performance Data

Data sourced from comparative studies [1, 2].

Metric	Isoindoline Derivative (4a/4e)	Donepezil (Standard)	Interpretation
IC50 (AChE)	0.91 μ M (4a) / 0.007 μ M (4e)	0.014 – 0.14 μ M	Optimized isoindolines (4e) can surpass Donepezil potency.[5]
Binding Energy	-11.5 to -12.8 kcal/mol	-13.2 kcal/mol	Isoindolines show comparable affinity.
Key Interaction	- stack (Trp279, Trp86)	- stack (Trp279, Trp86)	Identical binding mode confirms mechanism.
Selectivity	High for AChE over BuChE	Moderate	Isoindoline steric bulk improves selectivity.

3. Structural Insight

The presence of electron-withdrawing groups (Cl, F) on the isoindoline phenyl ring enhances

interactions with aromatic residues in the AChE gorge.

Case Study B: Cyclooxygenase-2 (COX-2) Inhibition (Inflammation)

Objective: Compare Isoindoline hybrids against Celecoxib.

1. Mechanistic Rationale

COX-2 selective inhibition requires targeting the side pocket formed by Val523 (which is Ile523 in COX-1, blocking access).

- Celecoxib: Uses a sulfonamide group to anchor into the hydrophilic side pocket (Arg513, His90).
- Isoindolines: The dione oxygens act as hydrogen bond acceptors for Arg120 and Tyr355 at the channel entrance, while hydrophobic N-substituents penetrate the hydrophobic channel.

2. Performance Data

Data sourced from comparative studies [3, 4].

Metric	Isoindoline Hybrid (11d/VIc)	Celecoxib (Standard)	Interpretation
IC50 (COX-2)	0.11 μ M (11d)	0.05 – 0.09 μ M	Isoindolines approach standard potency.
Selectivity (SI)	>100 (COX-2/COX-1)	>300	Good selectivity, reduced gastric risk.
Docking Score	-10.5 to -12.5 kcal/mol	-11.8 kcal/mol	Isoindolines often score better due to shape complementarity.
H-Bond Target	Arg120, Tyr355	Arg513, His90	Distinct anchoring points; Isoindolines mimic arachidonic acid carboxylate binding.

Part 3: Visualization & Workflows

Comparative Docking Workflow

The following diagram illustrates the decision tree for a rigorous comparative study.

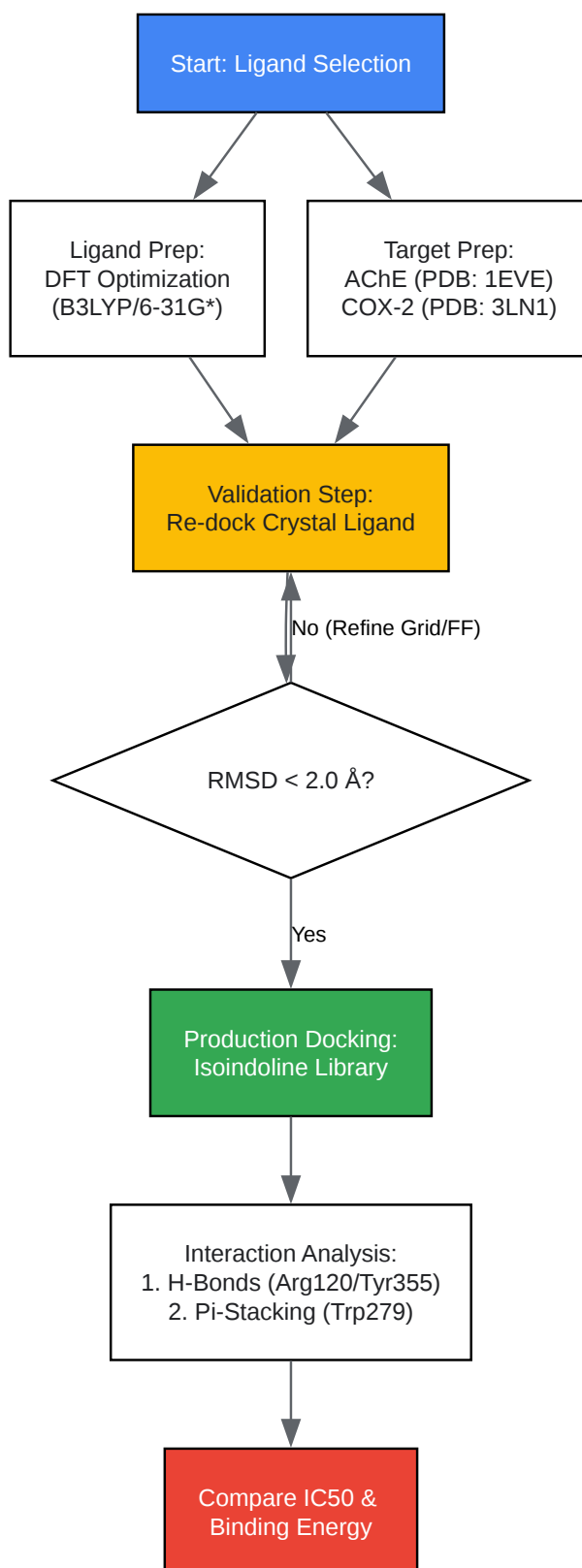

[Click to download full resolution via product page](#)

Caption: Figure 1: Validated workflow for comparative docking. The RMSD check (Yellow) is the critical "Go/No-Go" gate.

Isoindoline Interaction Map (COX-2 Context)

This diagram visualizes how a typical Isoindoline ligand interacts within the COX-2 active site compared to key residues.

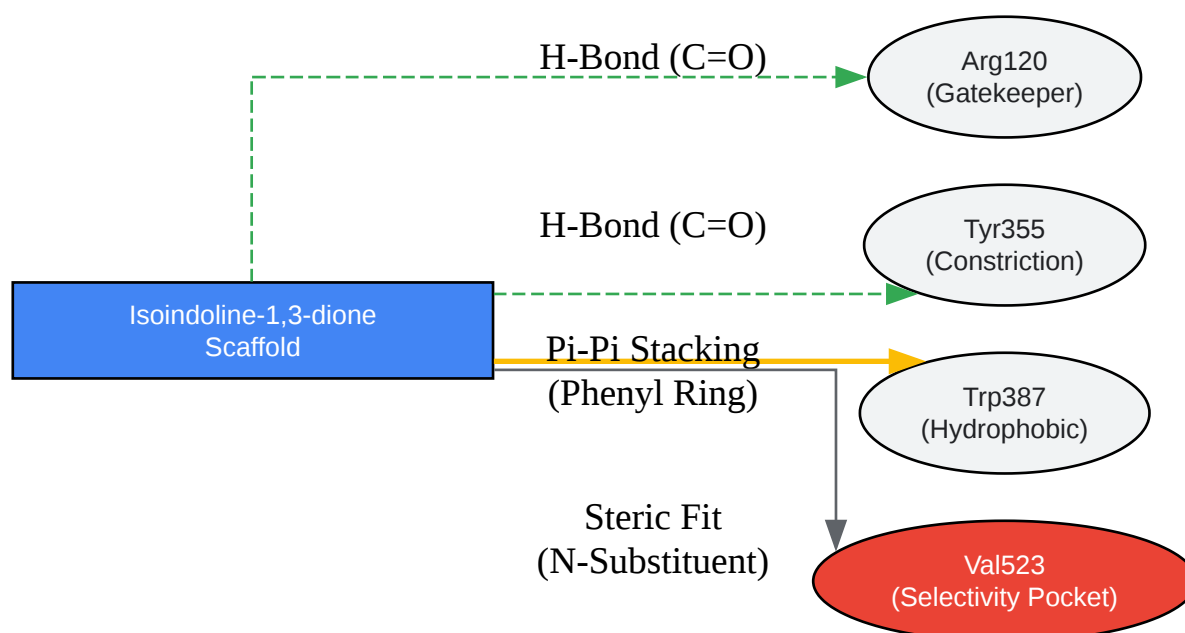

[Click to download full resolution via product page](#)

Caption: Figure 2: Pharmacophore map showing critical H-bond anchors (Arg120/Tyr355) and hydrophobic contacts for Isoindolines in COX-2.[6]

References

- Synthesis, docking and acetylcholinesterase inhibitory assessment of 2-(2-(4-Benzylpiperazin-1-yl)ethyl)isoindoline-1,3-dione derivatives. Source: PubMed / NIH
- 2-(2-(4-Benzoylpiperazin-1-yl)ethyl)isoindoline-1,3-dione derivatives: Synthesis, docking and acetylcholinesterase inhibitory evaluation. Source: Iranian Journal of Basic Medical Sciences
- Design, synthesis of novel isoindoline hybrids as COX-2 inhibitors: Anti-inflammatory, analgesic activities and docking study. Source: Bioorganic Chemistry (Elsevier)

- A New N-Substituted 1H-Isoindole-1,3(2H)-Dione Derivative—Synthesis, Structure and Affinity for Cyclooxygenase. Source: *Molecules* (MDPI)
- Isoindolinone inhibitors of the murine double minute 2 (MDM2)-p53 protein-protein interaction. Source: *Journal of Medicinal Chemistry* [6]

Need Custom Synthesis?

BenchChem offers custom synthesis for rare earth carbides and specific isotopic labeling.

Email: info@benchchem.com or [Request Quote Online](#).

Sources

- 1. Synthesis, In Vivo Anti-Inflammatory Activity, and Molecular Docking Studies of New Isatin Derivatives - PMC [[pmc.ncbi.nlm.nih.gov](https://pubmed.ncbi.nlm.nih.gov)]
- 2. [researchgate.net](https://www.researchgate.net) [[researchgate.net](https://www.researchgate.net)]
- 3. Design, synthesis of novel isoindoline hybrids as COX-2 inhibitors: Anti-inflammatory, analgesic activities and docking study - PubMed [pubmed.ncbi.nlm.nih.gov]
- 4. A New N-Substituted 1H-Isoindole-1,3(2H)-Dione Derivative—Synthesis, Structure and Affinity for Cyclooxygenase Based on In Vitro Studies and Molecular Docking - PMC [[pmc.ncbi.nlm.nih.gov](https://pubmed.ncbi.nlm.nih.gov)]
- 5. Synthesis, docking and acetylcholinesterase inhibitory assessment of 2-(2-(4-Benzylpiperazin-1-yl)ethyl)isoindoline-1,3-dione derivatives with potential anti-Alzheimer effects - PubMed [pubmed.ncbi.nlm.nih.gov]
- 6. [researchgate.net](https://www.researchgate.net) [[researchgate.net](https://www.researchgate.net)]
- To cite this document: BenchChem. [Comparative Docking Guide: Isoindoline Ligands in Drug Discovery]. BenchChem, [2026]. [Online PDF]. Available at: [<https://www.benchchem.com/product/b13247629/docs#comparative-docking-guide-isoindoline-ligands-in-drug-discovery>]

Disclaimer & Data Validity:

The information provided in this document is for Research Use Only (RUO) and is strictly not intended for diagnostic or therapeutic procedures. While BenchChem strives to provide

accurate protocols, we make no warranties, express or implied, regarding the fitness of this product for every specific experimental setup.

Technical Support: The protocols provided are for reference purposes. Unsure if this reagent suits your experiment?

Need Industrial/Bulk Grade? [Request Custom Synthesis Quote](#)

BenchChem

Our mission is to be the trusted global source of essential and advanced chemicals, empowering scientists and researchers to drive progress in science and industry.

Contact

Address: 3281 E Guasti Rd
Ontario, CA 91761, United States
Phone: (601) 213-4426
Email: info@benchchem.com

[Contact our Ph.D. Support Team for a compatibility check](#)