

Spectroscopic Data of 2-(4-Heptyloxybenzoyl)pyridine: An In-depth Technical Guide

Author: BenchChem Technical Support Team. **Date:** May 2026

Compound of Interest

Compound Name:	2-(4-Heptyloxybenzoyl)pyridine
CAS No.:	898780-12-6
Cat. No.:	B1324183

[Get Quote](#)

This technical guide provides a comprehensive analysis of the spectroscopic data for **2-(4-Heptyloxybenzoyl)pyridine**, a molecule of interest in medicinal chemistry and materials science. This document is intended for researchers, scientists, and drug development professionals, offering in-depth insights into the structural elucidation of this compound using fundamental spectroscopic techniques.

Introduction

2-(4-Heptyloxybenzoyl)pyridine belongs to the benzoylpyridine class of compounds, which are recognized for their diverse biological activities and applications as ligands in coordination chemistry. The structural integrity and purity of such compounds are paramount for their intended applications. Spectroscopic analysis is the cornerstone of chemical characterization, providing a detailed fingerprint of the molecular structure. This guide will delve into the interpretation of Proton Nuclear Magnetic Resonance (^1H NMR), Carbon-13 Nuclear Magnetic Resonance (^{13}C NMR), Fourier-Transform Infrared (FT-IR) Spectroscopy, and Mass Spectrometry (MS) data for the title compound.

The causality behind the experimental choices and the interpretation of the resulting spectra will be explained, grounded in established principles of spectroscopy. Each section will provide a self-validating system of analysis, ensuring trustworthiness and reproducibility.

Molecular Structure

The molecular structure of **2-(4-Heptyloxybenzoyl)pyridine** is pivotal to understanding its spectroscopic signature. The molecule consists of a pyridine ring attached to a benzoyl group, which is further substituted with a heptyloxy chain at the para position.

Caption: Molecular structure of **2-(4-Heptyloxybenzoyl)pyridine**.

Proton Nuclear Magnetic Resonance (^1H NMR) Spectroscopy

^1H NMR spectroscopy is a powerful technique for determining the structure of organic compounds by mapping the hydrogen atoms. The chemical shift (δ) of a proton is influenced by its local electronic environment.

Experimental Protocol: ^1H NMR Spectroscopy

- **Sample Preparation:** Dissolve approximately 5-10 mg of **2-(4-heptyloxybenzoyl)pyridine** in 0.5-0.7 mL of deuterated chloroform (CDCl_3). The choice of CDCl_3 is due to its excellent solubilizing properties for a wide range of organic compounds and its distinct solvent peak that does not typically interfere with the signals of interest.
- **Instrumentation:** Record the ^1H NMR spectrum on a 400 MHz or 500 MHz NMR spectrometer. Higher field strengths provide better signal dispersion and resolution.
- **Data Acquisition:** Acquire the spectrum at room temperature using a standard pulse sequence. Typically, 16-32 scans are sufficient to obtain a good signal-to-noise ratio.
- **Data Processing:** Process the raw data by applying a Fourier transform, phase correction, and baseline correction. Calibrate the chemical shift scale using the residual solvent peak of CDCl_3 (δ 7.26 ppm) or an internal standard like tetramethylsilane (TMS, δ 0.00 ppm).

Data Interpretation and Causality

The ^1H NMR spectrum of **2-(4-heptyloxybenzoyl)pyridine** is expected to show distinct signals for the aromatic protons on the pyridine and benzoyl rings, and the aliphatic protons of the heptyloxy chain.[1]

Chemical Shift (δ , ppm)	Multiplicity	Integration	Assignment	Rationale
-8.70	d	1H	H-6' (Pyridine)	The proton adjacent to the nitrogen atom is the most deshielded due to the inductive effect and anisotropic effect of the nitrogen.
-8.00	d	2H	H-2, H-6 (Benzoyl)	These protons are ortho to the electron-withdrawing carbonyl group, leading to significant deshielding.
-7.80	td	1H	H-4' (Pyridine)	This proton experiences deshielding from the aromatic ring currents.
-7.70	d	1H	H-3' (Pyridine)	Deshielded by the aromatic ring currents.
-7.40	ddd	1H	H-5' (Pyridine)	Deshielded by the aromatic ring currents.
-7.00	d	2H	H-3, H-5 (Benzoyl)	These protons are ortho to the electron-donating heptyloxy group,

				resulting in shielding compared to the ortho protons of the carbonyl group.
~4.05	t	2H	-OCH ₂ -	The methylene group directly attached to the oxygen atom is deshielded by the electronegative oxygen.
~1.80	quint	2H	-OCH ₂ CH ₂ -	Protons on the second carbon of the alkyl chain.
~1.45-1.30	m	8H	-(CH ₂) ₄ -	Overlapping signals for the central methylene groups of the heptyloxy chain.
~0.90	t	3H	-CH ₃	The terminal methyl group is the most shielded in the aliphatic region.

Note: The predicted chemical shifts are based on typical values for similar structures and may vary slightly in experimental data.

Carbon-13 Nuclear Magnetic Resonance (¹³C NMR) Spectroscopy

^{13}C NMR spectroscopy provides information about the carbon skeleton of a molecule. The chemical shifts are sensitive to the hybridization and electronic environment of the carbon atoms.

Experimental Protocol: ^{13}C NMR Spectroscopy

- **Sample Preparation:** Use the same sample prepared for ^1H NMR spectroscopy.
- **Instrumentation:** Record the ^{13}C NMR spectrum on the same NMR spectrometer used for ^1H NMR, typically at a frequency of 100 MHz or 125 MHz.
- **Data Acquisition:** Acquire a proton-decoupled ^{13}C NMR spectrum to simplify the spectrum to a series of singlets for each unique carbon atom. A larger number of scans (e.g., 1024 or more) is generally required due to the low natural abundance of the ^{13}C isotope.
- **Data Processing:** Process the data similarly to the ^1H NMR spectrum. The solvent peak of CDCl_3 (δ 77.16 ppm) is used for chemical shift calibration.

Data Interpretation and Causality

The ^{13}C NMR spectrum will show distinct signals for the carbonyl carbon, the aromatic carbons, and the aliphatic carbons of the heptyloxy chain.

Chemical Shift (δ , ppm)	Assignment	Rationale
~194.0	C=O	The carbonyl carbon is highly deshielded due to the electronegativity of the oxygen atom and its sp^2 hybridization.
~163.0	C-4 (Benzoyl)	The carbon atom attached to the oxygen of the heptyloxy group is deshielded.
~155.0	C-2' (Pyridine)	The carbon atom attached to the carbonyl group is deshielded.
~149.0	C-6' (Pyridine)	The carbon adjacent to the nitrogen atom is deshielded.
~137.0	C-4' (Pyridine)	Aromatic carbon in the pyridine ring.
~132.0	C-2, C-6 (Benzoyl)	Aromatic carbons ortho to the carbonyl group.
~130.0	C-1 (Benzoyl)	The quaternary carbon of the benzoyl ring.
~126.0	C-3' (Pyridine)	Aromatic carbon in the pyridine ring.
~122.0	C-5' (Pyridine)	Aromatic carbon in the pyridine ring.
~114.0	C-3, C-5 (Benzoyl)	Aromatic carbons ortho to the heptyloxy group, shielded by its electron-donating effect.
~68.0	-OCH ₂ -	The carbon atom directly bonded to the electronegative oxygen is deshielded.
~31.8, 29.2, 26.0, 22.6	-(CH ₂) ₅ -	Aliphatic carbons of the heptyloxy chain.

~14.1

-CH₃

The terminal methyl carbon is the most shielded.

Note: These are predicted chemical shifts. Actual values can be confirmed using 2D NMR techniques like HSQC and HMBC.

Fourier-Transform Infrared (FT-IR) Spectroscopy

FT-IR spectroscopy is used to identify the functional groups present in a molecule by measuring the absorption of infrared radiation, which excites molecular vibrations.

Experimental Protocol: FT-IR Spectroscopy

- **Sample Preparation:** The sample can be analyzed as a thin film on a salt plate (e.g., NaCl or KBr) or by using an Attenuated Total Reflectance (ATR) accessory. For the thin film method, dissolve a small amount of the compound in a volatile solvent, apply a drop to the salt plate, and allow the solvent to evaporate.
- **Instrumentation:** Record the spectrum using an FT-IR spectrometer.
- **Data Acquisition:** Acquire the spectrum over the range of 4000-400 cm⁻¹. A background spectrum of the clean salt plate or ATR crystal should be recorded and subtracted from the sample spectrum.

Data Interpretation and Causality

The FT-IR spectrum of **2-(4-heptyloxybenzoyl)pyridine** will exhibit characteristic absorption bands for its functional groups.^[2]

Wavenumber (cm ⁻¹)	Vibration	Functional Group	Rationale
~3050	C-H stretch	Aromatic	Stretching vibrations of C-H bonds on the pyridine and benzoyl rings.
~2950-2850	C-H stretch	Aliphatic	Stretching vibrations of C-H bonds in the heptyloxy chain.
~1660	C=O stretch	Ketone	The strong absorption is characteristic of the carbonyl group in a diaryl ketone. Conjugation with the aromatic rings lowers the frequency from a typical aliphatic ketone.
~1600, 1580, 1470	C=C stretch	Aromatic	Stretching vibrations of the carbon-carbon double bonds within the aromatic rings.
~1250	C-O stretch	Aryl-alkyl ether	Asymmetric stretching of the C-O-C bond of the heptyloxy group.
~1170	C-O stretch	Aryl-alkyl ether	Symmetric stretching of the C-O-C bond.

Mass Spectrometry (MS)

Mass spectrometry is an analytical technique that measures the mass-to-charge ratio (m/z) of ions. It provides information about the molecular weight and fragmentation pattern of a compound, which aids in its structural elucidation.

Experimental Protocol: Mass Spectrometry

- **Sample Introduction:** Introduce a dilute solution of the sample into the mass spectrometer via direct infusion or through a liquid chromatography (LC) system.
- **Ionization:** Use a soft ionization technique such as Electrospray Ionization (ESI) or Atmospheric Pressure Chemical Ionization (APCI) to generate molecular ions with minimal fragmentation.
- **Mass Analysis:** Analyze the ions using a mass analyzer such as a quadrupole, time-of-flight (TOF), or Orbitrap. High-resolution mass spectrometry (HRMS) is preferred for accurate mass determination and molecular formula confirmation.
- **Tandem MS (MS/MS):** To obtain structural information, perform fragmentation analysis by selecting the molecular ion and subjecting it to collision-induced dissociation (CID).

Data Interpretation and Causality

The mass spectrum will provide the molecular weight of the compound and its fragmentation pattern.

High-Resolution Mass Spectrometry (HRMS): The calculated exact mass for the protonated molecule $[M+H]^+$ of **2-(4-heptyloxybenzoyl)pyridine** ($C_{19}H_{23}NO_2$) is 298.1807.[1]

Experimental determination of this mass with high accuracy confirms the elemental composition.

Fragmentation Analysis (MS/MS): The fragmentation of the $[M+H]^+$ ion can provide valuable structural information.[1]

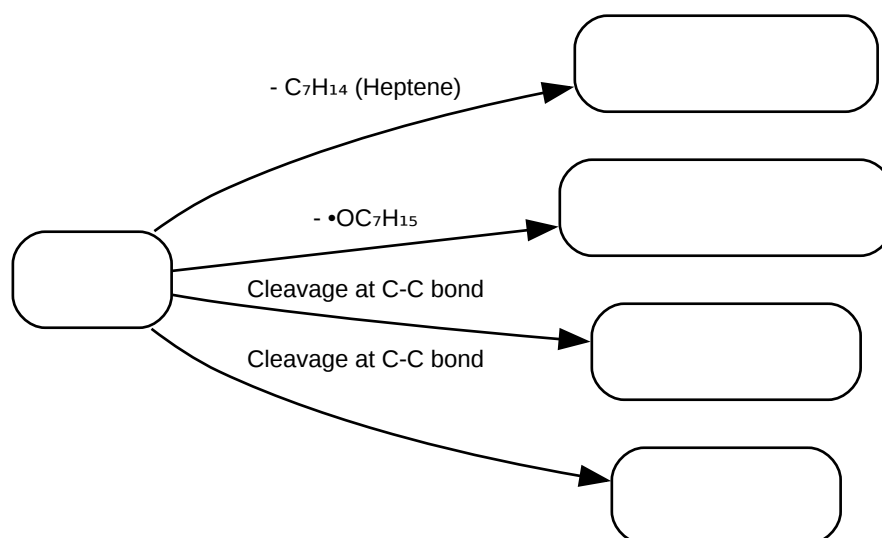

[Click to download full resolution via product page](#)

Caption: Predicted fragmentation pathways for **2-(4-Heptyloxybenzoyl)pyridine**.

- Loss of the heptyl chain: A common fragmentation for alkoxybenzenes is the cleavage of the alkyl chain. This can occur via a McLafferty rearrangement, leading to the loss of heptene (C₇H₁₄), or through cleavage of the C-O bond.
- Cleavage of the C-C bond: The bond between the carbonyl group and the pyridine ring or the benzoyl ring can cleave, leading to characteristic fragment ions.

Conclusion

The comprehensive spectroscopic analysis presented in this guide provides a robust framework for the structural characterization of **2-(4-heptyloxybenzoyl)pyridine**. The integration of ¹H NMR, ¹³C NMR, FT-IR, and Mass Spectrometry data allows for an unambiguous confirmation of the molecule's identity and purity. The detailed protocols and interpretation rationales serve as a valuable resource for researchers working with this and related compounds, ensuring scientific integrity and reproducibility in their work.

References

- Spectrochimica Acta Part A: Molecular and Biomolecular Spectroscopy. (2007). Spectral characterization and crystal structure of 2-benzoylpyridine nicotinoyl hydrazone. 66(2), 353-358. Available from: [\[Link\]](#)

- ChemPhysChem. (2021). Structural and Spectroscopic Properties of Benzoylpyridine-Based Hydrazones. 22(6), 533-541. Available from: [\[Link\]](#)
- Journal of the Serbian Chemical Society. (2001). Spectral characterization of iron(III) complexes of 2-benzoylpyridine N(4)-substituted thiosemicarbazones. 66(10), 661-668. Available from: [\[Link\]](#)
- Royal Society of Chemistry. (2009). Supplementary Information for A Zirconium Bis(amidate) Complex Exhibiting Improved Aminoalkene Cyclohydroamination Activity. Available from: [\[Link\]](#)
- MDPI. (2019). N-oxidation of Pyridine Derivatives - Supporting Information. Available from: [\[Link\]](#)
- Journal of Molecular Structure. (2017). Anyles of 4-benzoylpyridine – Crystal structure and spectroscopic properties. 1141, 46-55. Available from: [\[Link\]](#)
- Human Metabolome Database. ¹³C NMR Spectrum (1D, 25.16 MHz, CDCl₃, experimental) (HMDB0061888). Available from: [\[Link\]](#)
- PubChem. 2-Benzoylpyridine. Available from: [\[Link\]](#)
- Varian, Inc. ¹H NMR (400MHz, pyridine-d₅, 363K) 1-heptaacetate. Available from: [\[Link\]](#)
- Human Metabolome Database. ¹H NMR Spectrum (1D, 500 MHz, CDCl₃, experimental) (HMDB0000926). Available from: [\[Link\]](#)
- American Chemical Society. (2018). Aerobic C–N Bond Activation: A Simple Strategy to Construct Pyridines and Quinolines - Supporting Information. Available from: [\[Link\]](#)
- ResearchGate. (2009). FT-IR spectra. (A) Obtained after desorption of pyridine at different... Available from: [\[Link\]](#)
- NP-MRD. ¹³C NMR Spectrum (1D, 126 MHz, H₂O, predicted) (NP0218187). Available from: [\[Link\]](#)

- Human Metabolome Database. ^1H NMR Spectrum (1D, 90 MHz, CDCl_3 , experimental) (HMDB0061888). Available from: [\[Link\]](#)
- ResearchGate. (2020). ^{13}C NMR chemical shifts (δ , ppm) of pyridine in various solvents. Available from: [\[Link\]](#)
- ResearchGate. (2014). FTIR (a) and pyridine-FTIR (b) spectra of samples. Available from: [\[Link\]](#)
- University of California, Los Angeles. ^{13}C NMR Chemical Shift Table. Available from: [\[Link\]](#)
- ResearchGate. (2023). FTIR spectrum for Pyridine. Available from: [\[Link\]](#)
- ResearchGate. (2020). a FTIR spectra of pyridine adsorption of support samples, b FTIR... Available from: [\[Link\]](#)
- Journal of Chemical Information and Modeling. (2023). Communicating Mass Spectrometry Quality Information in mzQC with Python, R, and Java. 63(15), 4735-4743. Available from: [\[Link\]](#)
- SpringerLink. (2016). Quantitative analysis of amphiphilic N-alkyloxypyridinecarboximidamide by liquid chromatography–tandem mass spectrometry. Available from: [\[Link\]](#)
- ResearchGate. (2019). FTIR spectra of 2-acetylpyridine (a), 4-nitrobenzaldehyde (b), 4 ... Available from: [\[Link\]](#)
- MassBank. pyridine. Available from: [\[Link\]](#)

Need Custom Synthesis?

BenchChem offers custom synthesis for rare earth carbides and specific isotopic labeling.

Email: info@benchchem.com or [Request Quote Online](#).

Sources

- [1. benchchem.com \[benchchem.com\]](https://www.benchchem.com)

- [2. 2-Benzoylpyridine | C12H9NO | CID 7038 - PubChem \[pubchem.ncbi.nlm.nih.gov\]](#)
- To cite this document: BenchChem. [Spectroscopic Data of 2-(4-Heptyloxybenzoyl)pyridine: An In-depth Technical Guide]. BenchChem, [2026]. [Online PDF]. Available at: [<https://www.benchchem.com/product/b1324183/docs#spectroscopic-data-of-2-4-heptyloxybenzoyl-pyridine-an-in-depth-technical-guide>]

Disclaimer & Data Validity:

The information provided in this document is for Research Use Only (RUO) and is strictly not intended for diagnostic or therapeutic procedures. While BenchChem strives to provide accurate protocols, we make no warranties, express or implied, regarding the fitness of this product for every specific experimental setup.

Technical Support: The protocols provided are for reference purposes. Unsure if this reagent suits your experiment?

Need Industrial/Bulk Grade? [Request Custom Synthesis Quote](#)

BenchChem

Our mission is to be the trusted global source of essential and advanced chemicals, empowering scientists and researchers to drive progress in science and industry.

Contact

Address: 3281 E Guasti Rd
Ontario, CA 91761, United States
Phone: (601) 213-4426
Email: info@benchchem.com

[Contact our Ph.D. Support Team for a compatibility check](#)