

Mass Spectrometry Fragmentation Patterns of Fluorinated Thiophenes

Author: BenchChem Technical Support Team. **Date:** May 2026

Compound of Interest

Compound Name: 5-(1,3-Dioxolan-2-yl)-2-(3-fluorobenzoyl)thiophene

CAS No.: 898773-38-1

Cat. No.: B1324155

[Get Quote](#)

Executive Summary

Fluorinated thiophenes are critical motifs in modern drug discovery (e.g., bioisosteres for metabolic stability) and organic electronics (e.g., donor polymers). Unlike their chlorinated or brominated analogs, fluorinated thiophenes exhibit unique mass spectral behaviors due to the high electronegativity of fluorine and the exceptional strength of the C–F bond (approx. 485 kJ/mol).

This guide compares the fragmentation of fluorinated thiophenes against non-fluorinated and chlorinated alternatives, providing a self-validating workflow for structural elucidation.

Mechanistic Principles: The "Fluorine Effect"

To interpret the mass spectra of fluorinated thiophenes, one must understand how fluorine alters the standard "Thiophene Ring Fragmentation" (TRF) pathway.

Stability vs. Lability

- Thiophene (Standard): Under Electron Ionization (EI), the molecular ion (m/z 78) is stable but eventually fragments via ring opening to yield m/z 45 and m/z 39.
- Chlorothiophenes: The C–Cl bond is relatively weak (339 kJ/mol). Fragmentation often begins with the loss of the halogen radical (m/z 35) or m/z 51 elimination.
- Fluorothiophenes: The C–F bond is the strongest single bond in organic chemistry. Direct loss of a fluorine radical (m/z 19), M-19 is energetically unfavorable and rarely the base peak. Instead, the molecule prefers to undergo ring scission retaining the fluorine atom, or ejecting stable neutrals like m/z 18 or m/z 20.

Characteristic Fragmentation Pathways

The fragmentation of 2,5-difluorothiophene (MW 120) serves as a primary case study for this class.

Precursor Ion ()	Transition	Product Ion	m/z	Mechanism
C ₄ H ₂ F ₂ S (120)	Primary	Molecular Ion	120	High stability due to aromaticity.
Loss of CSF	C ₃ H ₂ F ⁺	57		Ring opening followed by ejection of neutral fluorothioformaldehyde (CSF).
Loss of CS	C ₃ H ₂ F ₂ ⁺	76		Extrusion of sulfur as CS (common in thiophenes).
Loss of C ₂ F ₂	C ₂ H ₂ S ⁺	58		Retro-Diels-Alder type cleavage.

“

Critical Insight: The presence of the m/z 57 peak (

) is diagnostic for fluorinated thiophenes, distinguishing them from alkyl thiophenes where m/z 57 typically represents a butyl chain (

).

Comparative Analysis: Fluoro- vs. Chloro- vs. Unsubstituted

The following table contrasts the spectral signatures of 2-substituted thiophenes.

Feature	2-Fluorothiophene	2-Chlorothiophene	Thiophene (Unsubstituted)
Molecular Ion ()	Dominant (Base Peak usually)	Strong	Strong
Isotope Pattern	Monoisotopic (Only ^{19}F)	3:1 Ratio ($^{35}\text{Cl} : ^{37}\text{Cl}$)	Standard (^{34}S contribution ~4%)
Halogen Loss	Rare/Low Intensity (M-19)	Common (M-35/37)	N/A
Base Fragment	Ring opening products (e.g.,)	(m/z 45) or	(m/z 39)
Neutral Loss	Ejection of CSF (44 Da) or HF (20 Da)	Ejection of CS or Cl	Ejection of CS or C_2H_2

Visualizing the Fragmentation Pathway

The diagram below illustrates the divergent pathways between Fluorinated and Chlorinated thiophenes.

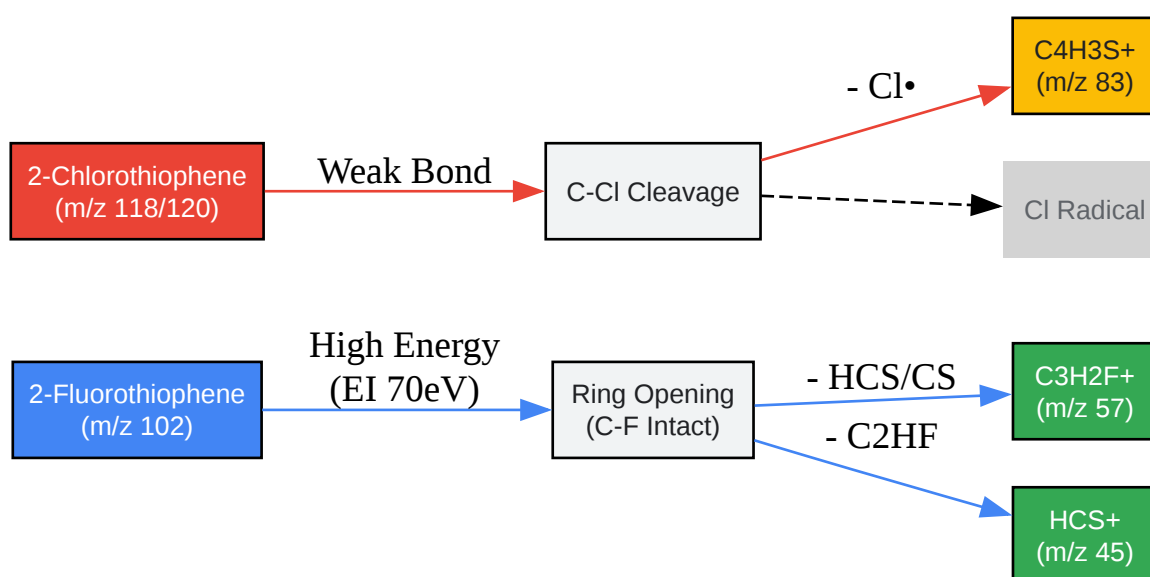

[Click to download full resolution via product page](#)

Figure 1: Divergent fragmentation pathways. Fluorothiophenes resist halogen loss, favoring skeletal rearrangement, while chlorothiophenes readily lose the halogen.

Experimental Protocol: Structural Validation

To confirm the presence of a fluorinated thiophene moiety in a drug candidate or polymer, follow this self-validating workflow.

Step 1: Isotope Pattern Analysis (Pre-Fragmentation)

Before analyzing fragmentation, validate the elemental composition using the molecular ion.

- Protocol: Acquire full-scan MS (m/z 50–500) in positive mode.
- Validation Check:
 - If Cl is present: Look for $M+2$ peak at ~33% intensity.
 - If F is present: No $M+2$ peak (beyond natural $^{13}\text{C}/^{34}\text{S}$). The peak shape should be sharp and monoisotopic.
 - Note: If multiple F atoms are present, the mass defect will be negative ($F = 18.9984$ Da), slightly shifting the centroid to a lower mass than the nominal integer.

Step 2: Hard Ionization (EI) for Fingerprinting

Use Electron Ionization (70 eV) to generate diagnostic fragments.

- Inject sample via GC-MS or Direct Insertion Probe (DIP).
- Scan Range: m/z 30 to $[M+50]$.
- Search for Diagnostic Ions:
 - m/z 57 (): Strong indicator of fluorothiophene.
 - m/z 45 ()

): Common to all thiophenes, confirms the sulfur heterocycle.

- M-20 (

): Check for a peak 20 Da below the molecular ion. This confirms the presence of F and H on the ring or adjacent chains.

Step 3: Soft Ionization (ESI/APCI) for Molecular Weight

For complex drugs or polymers (e.g., P3HT analogs):

- Use ESI+ or APCI+.
- Fluorinated thiophenes are less basic than alkyl thiophenes. You may need to use APCI or add a dopant (e.g., formic acid) to encourage protonation

.

- Validation: The

should be the base peak with minimal in-source fragmentation.

Decision Tree for Unknown Identification

Use this logic flow to classify an unknown thiophene derivative based on MS data.

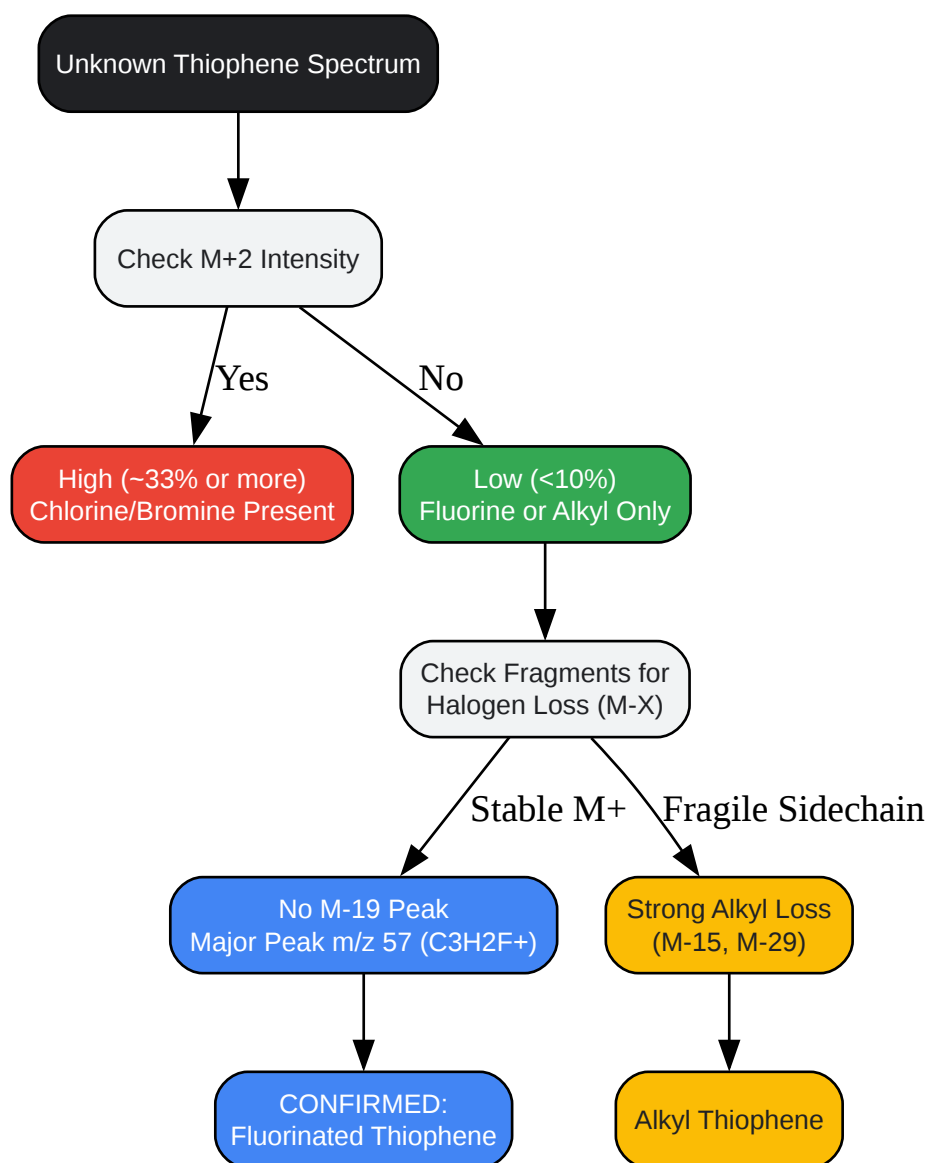

[Click to download full resolution via product page](#)

Figure 2: Logic flow for identifying fluorinated thiophenes vs. alkyl or chloro-analogs.

References

- NIST Mass Spectrometry Data Center. Mass Spectrum of 2,5-Difluorothiophene (CID 577446). PubChem.[1][2][3] Available at: [\[Link\]](#)
- Meyerson, S. & Fields, E. K. (1968). Organic Ions in the Gas Phase. Fragmentation of Thiophene.[4] Spectrochimica Acta Part B. (Foundational mechanism for thiophene ring opening).

- Pomerantz, M. et al. (2008).[5] A Facile and Improved Synthesis of 3-Fluorothiophene. Synthesis. Available at: [\[Link\]](#)
- Inductively Coupled Plasma Mass Spectrometry (ICP-MS) for Fluorinated Compounds. (2021). Trends towards Effective Analysis of Fluorinated Compounds.[6] PMC. Available at: [\[Link\]](#)
- Lou, X. et al. (2018). Fragmentation of organic ions bearing fixed multiple charges observed in MALDI MS.[7][8] Journal of Mass Spectrometry.[8] Available at: [\[Link\]](#)

Need Custom Synthesis?

BenchChem offers custom synthesis for rare earth carbides and specific isotopic labeling.

Email: info@benchchem.com or [Request Quote Online](#).

Sources

- 1. 2,5-Dihydrothiophene | C₄H₆S | CID 137168 - PubChem [pubchem.ncbi.nlm.nih.gov]
- 2. 2,5-Diphenylthiophene | C₁₆H₁₂S | CID 74050 - PubChem [pubchem.ncbi.nlm.nih.gov]
- 3. 2,5-Difluorothiophene | C₄H₂F₂S | CID 577446 - PubChem [pubchem.ncbi.nlm.nih.gov]
- 4. [researchgate.net](https://www.researchgate.net) [[researchgate.net](https://www.researchgate.net)]
- 5. Thieme E-Journals - Synthesis / Abstract [[thieme-connect.de](https://www.thieme-connect.de)]
- 6. Trends towards Effective Analysis of Fluorinated Compounds Using Inductively Coupled Plasma Mass Spectrometry (ICP-MS) - PMC [[pmc.ncbi.nlm.nih.gov](https://pubmed.ncbi.nlm.nih.gov)]
- 7. Fragmentation of organic ions bearing fixed multiple charges observed in MALDI MS - PubMed [pubmed.ncbi.nlm.nih.gov]
- 8. [pure.tue.nl](https://www.pure.tue.nl) [[pure.tue.nl](https://www.pure.tue.nl)]
- To cite this document: BenchChem. [Mass Spectrometry Fragmentation Patterns of Fluorinated Thiophenes]. BenchChem, [2026]. [Online PDF]. Available at: [<https://www.benchchem.com/product/b1324155/docs#mass-spectrometry-fragmentation-patterns-of-fluorinated-thiophenes>]

Disclaimer & Data Validity:

The information provided in this document is for Research Use Only (RUO) and is strictly not intended for diagnostic or therapeutic procedures. While BenchChem strives to provide accurate protocols, we make no warranties, express or implied, regarding the fitness of this product for every specific experimental setup.

Technical Support: The protocols provided are for reference purposes. Unsure if this reagent suits your experiment?

Need Industrial/Bulk Grade? [Request Custom Synthesis Quote](#)

BenchChem

Our mission is to be the trusted global source of essential and advanced chemicals, empowering scientists and researchers to drive progress in science and industry.

Contact

Address: 3281 E Guasti Rd
Ontario, CA 91761, United States
Phone: (601) 213-4426
Email: info@benchchem.com

[Contact our Ph.D. Support Team for a compatibility check](#)