

# Technical Support Center: Functionalization of the 1,5-Naphthyridine Ring

**Author:** BenchChem Technical Support Team. **Date:** May 2026

## Compound of Interest

Compound Name: 1-(1,5-Naphthyridin-3-yl)ethanone

CAS No.: 1246088-62-9

Cat. No.: B1322601

[Get Quote](#)

Prepared by: Gemini, Senior Application Scientist

Welcome to the technical support center for the synthetic chemistry of 1,5-naphthyridines. This guide is designed for researchers, medicinal chemists, and process development scientists who are navigating the unique challenges of modifying this important heterocyclic scaffold. The inherent electronic properties of the 1,5-naphthyridine ring, characterized by two electron-withdrawing nitrogen atoms, present distinct hurdles in achieving selective and efficient functionalization.

This document is structured as a dynamic troubleshooting resource. Instead of a static manual, it directly addresses common experimental failures and frequently asked questions in a practical, Q&A format. We will delve into the causality behind these challenges and provide field-proven strategies to overcome them.

## Section 1: Troubleshooting Guide - Common Experimental Issues

This section addresses specific problems you may encounter at the bench. Each answer explains the underlying chemical principles and provides actionable steps for remediation.

## Question 1: My electrophilic aromatic substitution (e.g., bromination, nitration) on the parent 1,5-naphthyridine ring is failing or giving very low yields. Why is this happening and what can I do?

Answer:

This is a frequently encountered issue rooted in the fundamental electronic nature of the 1,5-naphthyridine system. The two nitrogen atoms exert a powerful electron-withdrawing and deactivating effect on the ring, making it significantly less nucleophilic than benzene or even pyridine.<sup>[1]</sup> Consequently, it is highly resistant to classical electrophilic aromatic substitution (SEAr).

Root Cause Analysis:

- **Electronic Deactivation:** The pyridine-like nitrogen atoms inductively withdraw electron density and their lone pairs are part of the aromatic system, making the ring "electron-poor." This disfavors attack by electrophiles, which are seeking electron-rich centers.
- **Protonation under Acidic Conditions:** Many SEAr reactions (like nitration using  $\text{H}_2\text{SO}_4/\text{HNO}_3$ ) are conducted in strong acid. Under these conditions, the basic nitrogen atoms are protonated, which further increases the electron-deficient character of the ring, essentially shutting down reactivity.

Troubleshooting Strategies:

- **Force the Conditions (with caution):** While often inefficient, forcing the reaction conditions with stronger reagents or higher temperatures can sometimes yield the desired product. For example, direct bromination may require oleum as a solvent. However, this approach often leads to decomposition and should be considered a last resort.<sup>[1]</sup>
- **Leverage N-Oxide Chemistry:** This is a classic and highly effective strategy. Oxidation of one or both nitrogen atoms to the corresponding N-oxide dramatically alters the ring's electronics.

- Mechanism of Action: The N-oxide group is a strong activating group for substitution at the positions ortho and para to it (C2, C4, C6, C8). It acts as an electron-donating group through resonance, making these positions more susceptible to electrophilic attack.
- Practical Steps: Treat the 1,5-naphthyridine with an oxidizing agent like m-CPBA. The resulting N-oxide can then be subjected to electrophilic substitution (e.g., nitration). The N-oxide can be subsequently removed (deoxygenated) using a reducing agent like  $\text{PCl}_3$  or  $\text{PPh}_3$  to yield the functionalized 1,5-naphthyridine.[2]
- Consider Radical Pathways: For introducing alkyl or acyl groups, Minisci-type reactions, which proceed via a radical mechanism, are well-suited for electron-deficient heterocycles. Photoredox catalysis has also emerged as a powerful tool for direct C-H functionalization under milder conditions.[2][3]

## Question 2: My palladium-catalyzed cross-coupling reaction (Suzuki, Buchwald-Hartwig, etc.) on a halo-1,5-naphthyridine is sluggish, requires high catalyst loading, or fails completely. Is the catalyst being poisoned?

Answer:

Yes, catalyst inhibition or deactivation is the most probable cause. The lone pair of electrons on the ring nitrogen atoms can act as ligands, coordinating strongly to the palladium center.[2] This coordination can saturate the metal's coordination sphere, preventing the necessary steps of the catalytic cycle (e.g., oxidative addition, reductive elimination) from occurring, thereby "poisoning" the catalyst.

Troubleshooting Strategies:

- Ligand Selection is Critical: The choice of ancillary ligand is paramount to success. Bulky, electron-rich phosphine ligands are often required to outcompete the naphthyridine nitrogen for coordination to the palladium center and to promote the reductive elimination step.
  - For Suzuki Couplings: SPhos, XPhos, or RuPhos are excellent starting points.

- For Buchwald-Hartwig Aminations: Josiphos-type ligands or Xantphos can be very effective.[2]
- Optimize the Base and Solvent: The choice of base can significantly impact the reaction. Weaker bases like  $K_2CO_3$  or  $Cs_2CO_3$  are often preferred over stronger bases like alkoxides, which can lead to side reactions. Anhydrous, polar aprotic solvents like dioxane, DMF, or toluene are typically used.
- Increase Catalyst Loading: While not ideal for process chemistry, increasing the catalyst loading (e.g., from 1-2 mol% to 5-10 mol%) can sometimes overcome partial deactivation to provide the product in acceptable yields for discovery chemistry applications.
- Consider Pre-catalyst Choice: Use modern, well-defined palladium pre-catalysts (e.g., G3 or G4 palladacycles) which are designed for stability and efficient generation of the active catalytic species.

Reaction Type	Recommended Catalyst	Recommended Ligand	Recommended Base	Typical Solvent
Suzuki-Miyaura	$Pd(OAc)_2$ or $Pd_2(dba)_3$	SPhos or XPhos	$K_2CO_3$ or $K_3PO_4$	Dioxane/ $H_2O$
Buchwald-Hartwig Amination	$Pd_2(dba)_3$	Xantphos or BINAP	$Cs_2CO_3$ or NaOtBu	Toluene or Dioxane
Sonogashira	$Pd(PPh_3)_2Cl_2$	(none required)	$iPr_2NEt$	THF or DMF
Heck	$Pd(OAc)_2$	$PPh_3$ or $P(o-tol)_3$	$Et_3N$ or $K_2CO_3$	DMF or Acetonitrile

**Question 3: I am attempting a Nucleophilic Aromatic Substitution ( $S_NAr$ ) on a 2-halo-1,5-naphthyridine, but the reaction is not proceeding. I thought the ring was electron-poor?**

Answer:

You are correct; the electron-deficient nature of the ring is precisely what enables SNAr reactions. However, several factors must be aligned for the reaction to be successful. The issue likely lies with the leaving group ability, the nucleophile strength, or the reaction conditions.

#### Root Cause Analysis:

- **Leaving Group Ability:** The rate of SNAr is highly dependent on the leaving group. The general trend is  $F > Cl > Br > I$ . While this is counterintuitive based on acidity, the rate-determining step is typically the initial nucleophilic attack, which is facilitated by a more electronegative halogen that polarizes the C-X bond.
- **Activation of the Position:** SNAr reactions are most facile at positions that are ortho or para to the ring nitrogens (C2, C4, C6, C8). These positions are electronically activated towards nucleophilic attack, as the negative charge of the intermediate (Meisenheimer complex) can be delocalized onto the electronegative nitrogen atom.<sup>[4][5]</sup>
- **Nucleophile Strength:** The reaction requires a sufficiently strong nucleophile to attack the electron-poor ring. Weak nucleophiles may require harsh conditions.

#### Troubleshooting Strategies:

- **Increase Temperature:** SNAr reactions often require elevated temperatures (80-150 °C) to proceed at a reasonable rate. The use of a sealed tube or microwave reactor can be highly effective for safely reaching the required temperatures and dramatically reducing reaction times.<sup>[2]</sup>
- **Use a Stronger Nucleophile or Base:** If using an alcohol or amine nucleophile, adding a strong, non-nucleophilic base (e.g., NaH, KHMDS) to deprotonate it in situ will significantly increase its nucleophilicity.
- **Solvent Choice:** Polar aprotic solvents like DMSO, DMF, or NMP are ideal as they can solvate the cation of the nucleophile salt but do not solvate the anion, leaving it "naked" and more reactive.
- **Change the Leaving Group:** If you are starting from a bromo- or iodo-substituted naphthyridine and the reaction is failing, consider if a chloro- or even fluoro- derivative could be synthesized and used instead, as they are often more reactive in SNAr.

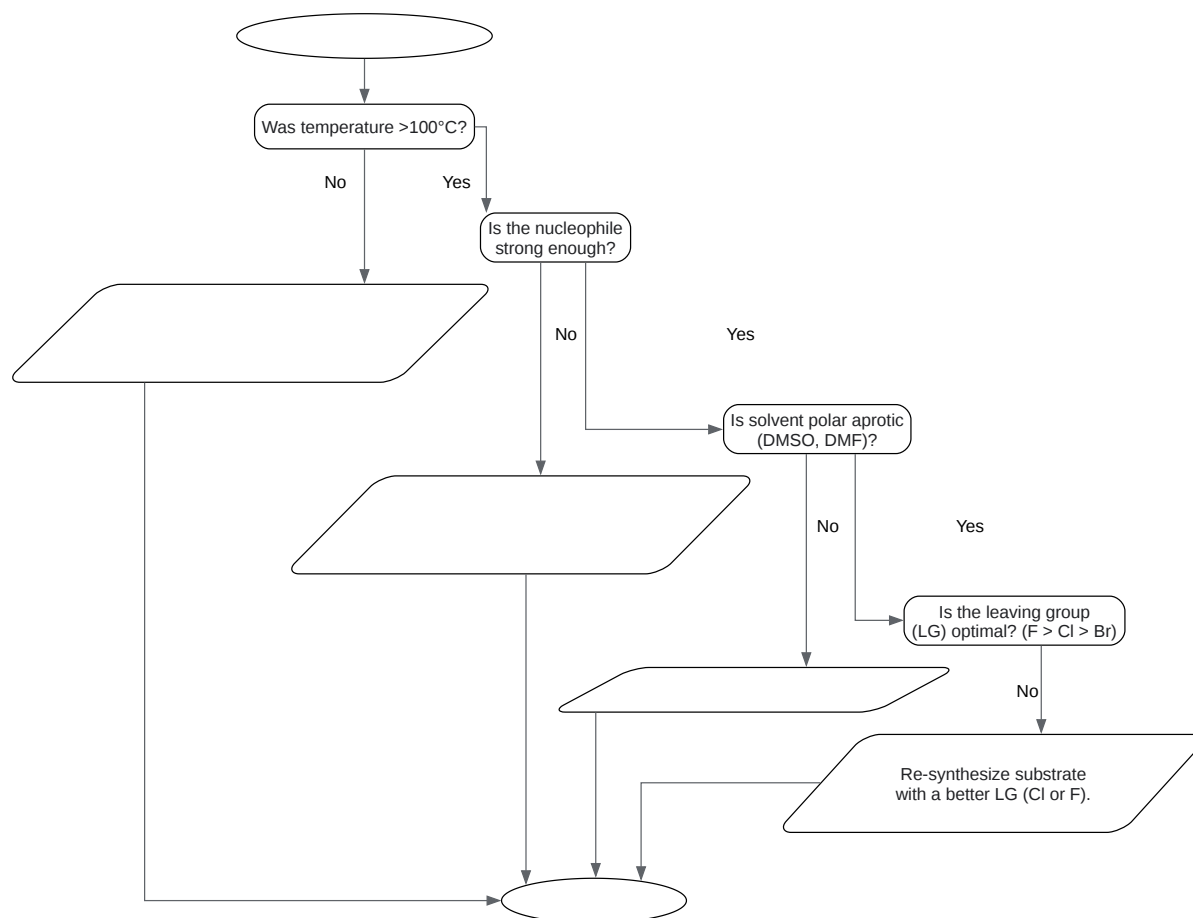

[Click to download full resolution via product page](#)

Caption: A decision tree for troubleshooting SNAr reactions.

## Section 2: Frequently Asked Questions (FAQs)

### Q1: What are the most reactive positions on the unsubstituted 1,5-naphthyridine ring for functionalization?

The reactivity is highly dependent on the type of reaction. The two pyridine rings influence each other, leading to a distinct reactivity pattern.

- For Electrophilic Attack (SEAr): The C3 and C7 positions are the least deactivated and are analogous to the  $\beta$ -position of pyridine. These are the preferred sites for electrophilic substitution, although harsh conditions are still required.[1]
- For Nucleophilic Attack (SNAr): The C2, C4, C6, and C8 positions are the most electron-deficient and are analogous to the  $\alpha$  and  $\gamma$  positions of pyridine. These positions readily undergo nucleophilic substitution, provided a suitable leaving group is present.[2]
- For Deprotonation/Metalation: The C4 and C8 positions are the most acidic due to their proximity to two nitrogen atoms, making them preferred sites for directed ortho-metalation (DoM) if a directing group is present, or direct deprotonation with strong bases.

Caption: Relative reactivity of positions on the 1,5-naphthyridine core.

### Q2: How can I achieve functionalization at the C4/C8 positions if they don't have a leaving group?

Direct C-H functionalization at the C4 and C8 positions is an excellent modern strategy.

- Direct Deprotonation-Electrophile Quench: Due to the acidity of the C4/C8 protons, strong bases like LDA or TMP-bases can selectively deprotonate these positions. The resulting anion can then be quenched with a variety of electrophiles (e.g., iodine, aldehydes, alkyl halides).[2]
- Minisci Reaction: As mentioned earlier, radical Minisci-type reactions show a strong preference for the C2, C4, and C6 positions of N-heterocycles, providing a direct method for alkylation or acylation without pre-functionalization.

- Transition Metal-Catalyzed C-H Activation: While still a developing area for this specific scaffold, directed C-H activation is a powerful tool. A directing group could be installed on a pre-functionalized ring (e.g., at C3) to direct a metal catalyst to activate the C4-H bond.

## Section 3: Key Experimental Protocols

These protocols are provided as validated starting points. Optimization for your specific substrate will likely be necessary.

### Protocol 1: Palladium-Catalyzed Suzuki-Miyaura Coupling on 2-Chloro-1,5-naphthyridine

This protocol describes the coupling of a generic arylboronic acid with 2-chloro-1,5-naphthyridine.

Materials:

- 2-Chloro-1,5-naphthyridine (1.0 eq)
- Arylboronic acid (1.2 eq)
- Palladium(II) Acetate ( $\text{Pd}(\text{OAc})_2$  - 0.02 eq)
- 2-Dicyclohexylphosphino-2',6'-dimethoxybiphenyl (SPhos - 0.04 eq)
- Potassium Carbonate ( $\text{K}_2\text{CO}_3$  - 3.0 eq)
- 1,4-Dioxane
- Water
- Nitrogen or Argon source

Procedure:

- To a dry Schlenk flask under an inert atmosphere ( $\text{N}_2$  or Ar), add 2-chloro-1,5-naphthyridine, the arylboronic acid, and  $\text{K}_2\text{CO}_3$ .

- In a separate vial, dissolve Pd(OAc)<sub>2</sub> and SPhos in a small amount of dioxane. Allow this solution to stir for 5-10 minutes to pre-form the catalyst.
- Add the catalyst solution to the Schlenk flask containing the solids.
- Add 1,4-dioxane and water to the reaction flask to create a 4:1 dioxane:water solvent mixture (concentration ~0.1 M with respect to the starting halide).
- Seal the flask and heat the reaction mixture to 100 °C with vigorous stirring.
- Monitor the reaction progress by TLC or LC-MS. Typical reaction times are 4-16 hours.
- Upon completion, cool the reaction to room temperature. Dilute with ethyl acetate and water.
- Separate the organic layer, wash with brine, dry over anhydrous sodium sulfate, and concentrate in vacuo.
- Purify the crude product by flash column chromatography on silica gel.

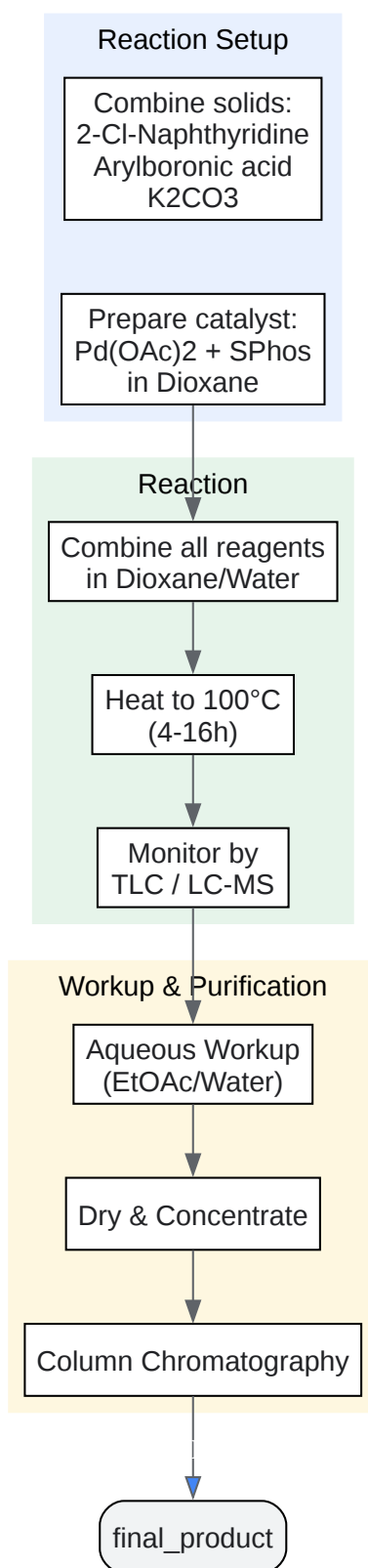

[Click to download full resolution via product page](#)

Caption: General workflow for synthesis and purification.

## References

- Fuertes, M., Masdeu, C., Martin-Encinas, E., Selas, A., Rubiales, G., Palacios, F., & Alonso, C. (2020). Synthetic Strategies, Reactivity and Applications of 1,5-Naphthyridines. *Molecules*, 25(14), 3252. [\[Link\]](#)
- Fuertes, M., et al. (2020). Synthetic Strategies, Reactivity and Applications of 1,5-Naphthyridines. ResearchGate. [\[Link\]](#)
- Masdeu, C., Fuertes, M., Martin-Encinas, E., Selas, A., Rubiales, G., Palacios, F., & Alonso, C. (2020). Fused 1,5-Naphthyridines: Synthetic Tools and Applications. *Molecules*, 25(15), 3508. [\[Link\]](#)
- Masdeu, C., et al. (2020). Fused 1,5-Naphthyridines: Synthetic Tools and Applications. MDPI. [\[Link\]](#)
- MDPI. (n.d.). 1,6-Naphthyridin-2(1H)-ones: Synthesis and Biomedical Applications. MDPI. [\[Link\]](#)
- Jiang, Z., et al. (2021). Tunable C–H functionalization and dearomatization enabled by an organic photocatalyst. *Nature Communications*. [\[Link\]](#)
- Frontier, A. (2026). How to Troubleshoot a Reaction. University of Rochester, Department of Chemistry. [\[Link\]](#)
- Wikipedia. (n.d.). Nucleophilic aromatic substitution. Wikipedia. [\[Link\]](#)
- Al-dujaili, A. H. (2019). Synthesis and Spectral Characterization of 1,5-Naphthyridine Derivatives through Cross-Coupling Suzuki Reaction. ResearchGate. [\[Link\]](#)
- Fuertes, M., et al. (2020). Synthetic Strategies, Reactivity and Applications of 1,5-Naphthyridines. PubMed. [\[Link\]](#)
- Berhault, A., et al. (2022). Synthesis and Reactivity of 1,4-Ethano-1,5-Naphthyridine Derivatives Using Microwave Activation or Flow Chemistry. ResearchGate. [\[Link\]](#)
- PHARMD GURU. (n.d.). NUCLEOPHILIC AROMATIC SUBSTITUTION. PHARMD GURU. [\[Link\]](#)

- ResearchGate. (n.d.). Metal catalyzed cyanation of 1,5-naphthyridines. ResearchGate. [[Link](#)]
- MDPI. (n.d.). Silver-Catalyzed Synthesis of Functionalized 1,7-Naphthyridine Derivatives. MDPI. [[Link](#)]
- Semantic Scholar. (n.d.). Synthetic Strategies, Reactivity and Applications of 1,5-Naphthyridines. Semantic Scholar. [[Link](#)]
- MDPI Books. (2021). Transition Metal Catalyzed Cross-Coupling Reactions. MDPI. [[Link](#)]
- Powers, I. G., & Uy, G. W. (2016). Advances in Photocatalysis: A Microreview of Visible Light Mediated Ruthenium and Iridium Catalyzed Organic Transformations. NIH Public Access. [[Link](#)]
- Bej, A., & Ghosh, K. (2021). Insight into functionalized-macrocycles-guided supramolecular photocatalysis. Beilstein Journal of Organic Chemistry. [[Link](#)]
- ResearchGate. (n.d.). Transition Metal-Catalyzed Couplings in Process Chemistry: Case Studies from the Pharmaceutical Industry. ResearchGate. [[Link](#)]
- ADDI. (2020). Synthetic Strategies, Reactivity and Applications of 1,5-Naphthyridines. ADDI. [[Link](#)]
- MDPI. (2023). Synthesis of Novel Benzo[b][2][6]naphthyridine Derivatives and Investigation of Their Potential as Scaffolds of MAO Inhibitors. MDPI. [[Link](#)]

### Need Custom Synthesis?

BenchChem offers custom synthesis for rare earth carbides and specific isotopic labeling.

Email: [info@benchchem.com](mailto:info@benchchem.com) or [Request Quote Online](#).

## Sources

- [1. pdf.benchchem.com](https://pdf.benchchem.com) [[pdf.benchchem.com](https://pdf.benchchem.com)]
- [2. Synthetic Strategies, Reactivity and Applications of 1,5-Naphthyridines - PMC](https://pubmed.ncbi.nlm.nih.gov/) [[pmc.ncbi.nlm.nih.gov](https://pubmed.ncbi.nlm.nih.gov/)]

- [3. Tunable C–H functionalization and dearomatization enabled by an organic photocatalyst - PMC \[pmc.ncbi.nlm.nih.gov\]](#)
- [4. Nucleophilic aromatic substitution - Wikipedia \[en.wikipedia.org\]](#)
- [5. pharmdguru.com \[pharmdguru.com\]](#)
- [6. mdpi.com \[mdpi.com\]](#)
- To cite this document: BenchChem. [Technical Support Center: Functionalization of the 1,5-Naphthyridine Ring]. BenchChem, [2026]. [Online PDF]. Available at: [<https://www.benchchem.com/product/b1322601/docs#technical-support-center-functionalization-of-the-1-5-naphthyridine-ring>]

---

### Disclaimer & Data Validity:

The information provided in this document is for Research Use Only (RUO) and is strictly not intended for diagnostic or therapeutic procedures. While BenchChem strives to provide accurate protocols, we make no warranties, express or implied, regarding the fitness of this product for every specific experimental setup.

**Technical Support:** The protocols provided are for reference purposes. Unsure if this reagent suits your experiment?

**Need Industrial/Bulk Grade?** [Request Custom Synthesis Quote](#)

## BenchChem

Our mission is to be the trusted global source of essential and advanced chemicals, empowering scientists and researchers to drive progress in science and industry.

### Contact

Address: 3281 E Guasti Rd  
Ontario, CA 91761, United States  
Phone: (601) 213-4426  
Email: [info@benchchem.com](mailto:info@benchchem.com)

Contact our Ph.D. Support Team for a compatibility check