

Technical Support Center: Ring-Expansion of Aziridines to Azetidines

Author: BenchChem Technical Support Team. **Date:** May 2026

Compound of Interest

Compound Name: *(r)-2-Methylazetidione hydrochloride*

CAS No.: 791614-71-6

Cat. No.: B1321207

[Get Quote](#)

Welcome to the technical support center for the synthesis of azetidines via aziridine ring expansion. This guide is designed for researchers, scientists, and professionals in drug development who are navigating the complexities of this powerful, yet sensitive, transformation. Here, we address common challenges and side reactions through a series of troubleshooting guides and frequently asked questions, grounded in mechanistic principles and practical laboratory experience.

Introduction: The Strain and Gain of Ring Expansion

The transformation of a three-membered aziridine to a four-membered azetidine is a synthetically valuable one-carbon homologation. This process leverages the inherent ring strain of the aziridine (approximately 27 kcal/mol) to drive the formation of the also strained, but comparatively more stable, azetidine ring (approx. 25.4 kcal/mol).[1][2] While elegant in concept, this delicate energetic balance means the reaction is often susceptible to various side reactions. This guide will help you diagnose and resolve these common issues.

Troubleshooting Guide & FAQs

Issue 1: Low or No Yield of the Desired Azetidine Product

Question: I am attempting a Lewis acid-catalyzed ring expansion of my N-substituted aziridine, but I am recovering mostly starting material or observing a complex mixture of products. What are the likely causes and how can I improve my yield?

Answer:

Low conversion or the formation of multiple products in aziridine ring expansions often points to issues with activation of the aziridine ring or the stability of the key intermediate. The reactivity of aziridines is highly dependent on the substituent on the nitrogen atom.^{[3][4]}

- Inadequate Aziridine Activation: "Non-activated" aziridines, those with electron-donating groups (like alkyls) on the nitrogen, are relatively stable and require activation by an electrophile to form an aziridinium ion, which then undergoes ring-opening/expansion.^{[4][5]}
^[6] If your Lewis acid is not strong enough or is being sequestered by other functional groups in your substrate or solvent, activation will be inefficient.
 - Troubleshooting:
 - Choice of Lewis Acid: Switch to a stronger Lewis acid. For instance, if you are using a mild Lewis acid like ZnCl_2 , consider more potent options such as $\text{BF}_3 \cdot \text{OEt}_2$ or TiCl_4 . Be mindful that harsher Lewis acids can sometimes promote undesired side reactions.
 - Solvent Effects: Ensure your solvent is anhydrous and non-coordinating. Protic solvents can interfere with the Lewis acid, and strongly coordinating solvents (like THF) can compete for binding, reducing its effectiveness. Dichloromethane (DCM) or dichloroethane (DCE) are often good starting points.
 - Temperature Control: Some ring expansions require thermal energy. If you are running the reaction at room temperature, a modest increase in temperature (e.g., to 40 °C or refluxing in DCM) might be necessary. Conversely, some highly reactive systems may require cooling to prevent decomposition.
- Decomposition of Starting Material or Product: Azetidines, while more stable than aziridines, are still strained rings and can be susceptible to decomposition under harsh conditions (e.g.,

strong acid, high temperatures).[1]

- Troubleshooting:

- Reaction Monitoring: Carefully monitor your reaction by TLC or LC-MS to determine the optimal reaction time. Prolonged reaction times can lead to product degradation.
- Work-up Procedure: Ensure your work-up procedure is appropriate. Quenching with a mild base (e.g., saturated NaHCO_3 solution) is often necessary to neutralize the Lewis acid and prevent product degradation on silica gel during purification.

Issue 2: Formation of an Undesired Regioisomer

Question: My aziridine is asymmetrically substituted. The ring expansion is working, but I am obtaining the wrong regioisomer of the azetidine, or a mixture of both. How can I control the regioselectivity?

Answer:

Regioselectivity in aziridine ring expansion is a common challenge and is dictated by the mechanism of the ring-opening of the intermediate aziridinium ion. The nucleophilic attack that leads to ring expansion can occur at either of the two carbons of the aziridine ring, and the preferred site is influenced by electronic and steric factors.[3][7]

- Mechanism and Regioselectivity: The ring-opening can proceed through an $\text{S}_{\text{n}}1$ -like or $\text{S}_{\text{n}}2$ -like pathway.
 - $\text{S}_{\text{n}}1$ Pathway: If a significant positive charge builds up on one of the ring carbons (i.e., a carbocation-like intermediate is formed), the nucleophile will attack the more substituted carbon, as this position can better stabilize the positive charge. This is often favored with aziridines bearing a substituent that can stabilize a carbocation (e.g., a phenyl group).
 - $\text{S}_{\text{n}}2$ Pathway: In the absence of a stabilizing group, the reaction is more likely to proceed via an $\text{S}_{\text{n}}2$ mechanism, where the nucleophile attacks the sterically least hindered carbon.
- Troubleshooting Strategies:

- Tuning the N-Substituent: The electronic nature of the nitrogen substituent plays a critical role. Electron-withdrawing groups ("activated" aziridines) make the ring carbons more electrophilic and susceptible to nucleophilic attack.[4][8]
- Choice of Catalyst/Reagents: The choice of Lewis acid or catalyst can influence the S_N1 vs. S_N2 character of the transition state. Harder Lewis acids may favor a more S_N1 -like pathway, while softer catalysts might favor an S_N2 -like attack. For instance, palladium-catalyzed ring-opening cross-coupling reactions have shown high regioselectivity, which can be tuned by the choice of ligands.[2]
- Substrate Design: If possible, modifying the substituents on the aziridine ring can be the most effective way to direct regioselectivity. Placing a bulky group on one of the carbons can sterically direct the nucleophile to the other carbon.

Visualizing Reaction Pathways

Below is a diagram illustrating the general mechanism for a Lewis acid-catalyzed ring expansion and a common side reaction pathway.

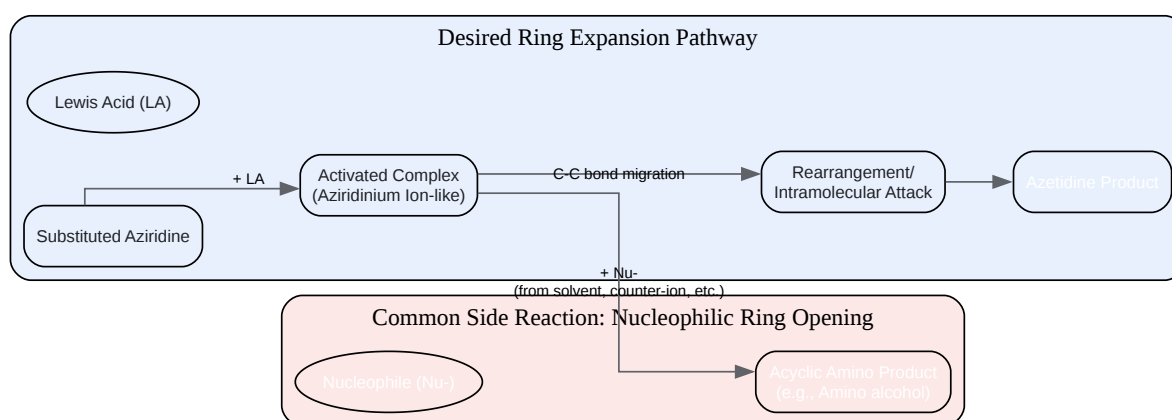

[Click to download full resolution via product page](#)

Caption: General pathways in Lewis acid-catalyzed aziridine ring expansion.

Issue 3: Predominant Formation of Acyclic Ring-Opened Products

Question: Instead of the desired azetidine, my main product is an acyclic compound, such as an amino alcohol or a diamine. Why is this happening and how can I favor the ring expansion?

Answer:

This is a classic problem where an external nucleophile successfully competes with the intended intramolecular rearrangement. The activated aziridinium intermediate is highly electrophilic and can be trapped by any nucleophile present in the reaction mixture.^{[3][5]}

- Sources of Competing Nucleophiles:
 - Counter-ions: The counter-ion from your Lewis acid (e.g., Cl^- from TiCl_4 , Br^- from BBr_3) or other salts can be nucleophilic.
 - Solvent: Protic solvents (like methanol or water) are excellent nucleophiles. Even seemingly innocuous solvents can participate in reactions.
 - Additives or Impurities: Any additives or impurities in your starting materials or solvents can act as nucleophiles.
- Troubleshooting and Mitigation:
 - Use Non-Nucleophilic Counter-ions: Employ Lewis acids with non-nucleophilic counter-ions, such as triflates (OTf^-) or tetrafluoroborates (BF_4^-). For example, using Trimethylsilyl trifluoromethanesulfonate (TMSOTf) can promote ring expansion while avoiding the introduction of a nucleophilic halide.
 - Strictly Anhydrous and Aprotic Conditions: Ensure your glassware is oven- or flame-dried and the reaction is run under an inert atmosphere (e.g., nitrogen or argon). Use freshly distilled, anhydrous, aprotic solvents.

- Quaternary Ammonium Salts: In some cases, the addition of a quaternary ammonium salt with a non-nucleophilic anion can help to control racemization and suppress side reactions by facilitating the desired S_N2-type ring opening.^[9]
- Temperature Control: Lowering the reaction temperature can sometimes favor the intramolecular rearrangement over the intermolecular nucleophilic attack, as the latter may have a higher activation energy.

Issue 4: Stevens Rearrangement vs. Cheletropic Extrusion

Question: I am trying to perform a one-carbon ring expansion using a diazo compound and a catalyst to form an aziridinium ylide, but I'm observing products derived from olefin extrusion. How can I promote the desired^{[7][8]}-Stevens rearrangement?

Answer:

The formation of an aziridinium ylide intermediate opens up two main reaction pathways: the desired^{[7][8]}-Stevens rearrangement to form the azetidine, and an undesired cheletropic extrusion of an olefin to give an imine.^[10]

- Controlling the Fate of the Aziridinium Ylide: The partitioning between these two pathways is highly sensitive to the reaction conditions and the catalyst used.
 - Catalyst Choice: This is the most critical factor. While traditional copper and rhodium catalysts are often used, they may not effectively suppress the cheletropic extrusion. Recent advances have shown that engineered biocatalysts, such as evolved variants of cytochrome P450, can be highly effective in promoting the^{[7][8]}-Stevens rearrangement with excellent enantioselectivity, effectively shutting down the extrusion pathway.^[10] The enzyme's active site provides a constrained environment that favors the rearrangement.
 - Substrate Structure: The substituents on the aziridine and the diazo compound can influence the stability of the ylide and the transition states for both pathways. Experimenting with different ester groups on the diazoacetate or different N-acyl groups on the aziridine may shift the balance.

Illustrative Protocol: Thermal Isomerization of a 2-Bromomethylaziridine

This protocol is an example of a ring expansion driven by the intramolecular displacement of a leaving group, a method explored by De Kimpe et al.[\[11\]](#)

Objective: To synthesize a 3-substituted azetidine from a 2-bromomethylaziridine via thermal rearrangement.

Materials:

- 2-bromomethyl-2-methyl-N-benzylaziridine (1 equivalent)
- Dimethyl sulfoxide (DMSO), anhydrous
- Saturated aqueous sodium bicarbonate (NaHCO_3)
- Ethyl acetate (EtOAc)
- Brine (saturated aqueous NaCl)
- Anhydrous magnesium sulfate (MgSO_4)
- Round-bottom flask, reflux condenser, magnetic stirrer, heating mantle

Procedure:

- Dissolve the 2-bromomethyl-2-methyl-N-benzylaziridine in anhydrous DMSO in a round-bottom flask equipped with a magnetic stir bar.
- Attach a reflux condenser and heat the solution to 70 °C under a nitrogen atmosphere.
- Monitor the reaction progress by TLC or LC-MS. The thermal isomerization from the kinetically formed aziridine to the thermodynamically more stable azetidine can take several hours.[\[11\]](#)
- Once the reaction is complete, allow the mixture to cool to room temperature.

- Pour the reaction mixture into a separatory funnel containing water and extract with ethyl acetate (3x).
- Combine the organic layers and wash with water and then brine to remove the DMSO.
- Dry the organic layer over anhydrous MgSO_4 , filter, and concentrate under reduced pressure.
- Purify the crude product by flash column chromatography on silica gel to yield the desired 3-bromo-3-methyl-N-benzylazetidine.

Troubleshooting Workflow

Here is a logical workflow to diagnose issues with aziridine ring expansion.

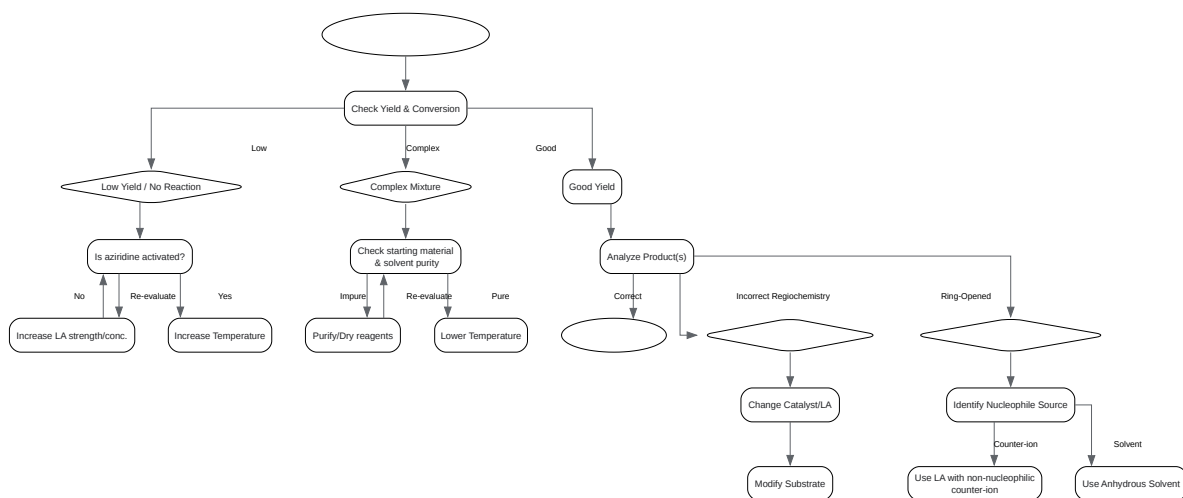

[Click to download full resolution via product page](#)

Caption: A step-by-step workflow for troubleshooting common issues.

References

- St. John-Campbell, S., K. K. Klausen, and J. M. Schomaker. "Recent updates and future perspectives in aziridine synthesis and reactivity." *Frontiers in Chemistry* 9 (2021): 757884. [\[Link\]](#)
- Srivastava, N., and H. J. Ha. "Regioselective ring opening of aziridine for synthesizing azaheterocycle." *Frontiers in Chemistry* 11 (2023): 1280633. [\[Link\]](#)
- Ghorai, M. K., et al. "Recent Advances in Transition Metal-Catalyzed Ring-Opening Reaction of Aziridine." *Compounds* 4.1 (2024): 38-63. [\[Link\]](#)
- Krása, T., and J. C. V. Veselý. "Recent Advances in the Synthesis and Reactivity of Azetidines: Strain-Driven Character of the Four-Membered Heterocycle." *Chemical Society Reviews* 50.8 (2021): 4979-5011. [\[Link\]](#)
- Minakata, S., and Y. Takeda. "Palladium-Catalyzed Regioselective and Stereospecific Ring-Opening Cross-Coupling of Aziridines: Experimental and Computational Studies." *Accounts of Chemical Research* 53.9 (2020): 1947-1961. [\[Link\]](#)
- Ghorai, M. K., A. Bhattacharyya, and S. Das. "Ring Expansions of Activated Aziridines and Azetidines." *Topics in Heterocyclic Chemistry* 41 (2015): 49-142. [\[Link\]](#)
- Singh, G. S., and M. D'hooghe. "Recent advances in synthetic facets of immensely reactive azetidines." *Organic & Biomolecular Chemistry* 15.38 (2017): 7993-8013. [\[Link\]](#)
- Dick, B. D., et al. "Biocatalytic One-Carbon Ring Expansion of Aziridines to Azetidines via a Highly Enantioselective[7][8]-Stevens Rearrangement." *Journal of the American Chemical Society* 144.4 (2022): 1568-1574. [\[Link\]](#)
- Choi, J., T. Yu, and H. J. Ha. "Alkylative Aziridine Ring-Opening Reactions." *Molecules* 26.6 (2021): 1703. [\[Link\]](#)
- Organic Chemistry Portal. "Synthesis of azetidines." [\[Link\]](#)
- Leclair, A. "Ring expansion of aziridines and azetidines for the synthesis of 5-membered azacycles." Group Seminar, EPFL (2018). [\[Link\]](#)

- Couty, F., and O. R. P. David. "Synthesis of azetidines from aziridines and epoxides." *Topics in Heterocyclic Chemistry* 41 (2015): 1-47. [[Link](#)]
- Choi, J., T. Yu, and H. J. Ha. "Alkylative Aziridine Ring-Opening Reactions." *Molecules* 26.6 (2021): 1703. [[Link](#)]
- Ghorai, M. K., et al. "Ring Expansions of Activated Aziridines and Azetidines." *SpringerLink*, 2015. [[Link](#)]
- Yadav, N. N., et al. "Preparation of Stable Bicyclic Aziridinium Ions and Their Ring-Opening for the Synthesis of Azaheterocycles." *Journal of Visualized Experiments* 138 (2018): e58145. [[Link](#)]
- Park, H., et al. "Lewis acid-catalyzed stereospecific ring expansion of aziridine-2-carboxylates to imidazolidin-2-ones." *Chemical Communications* 46 (2007): 4898-4900. [[Link](#)]
- Ha, H. J. "Synthetic Applications of Aziridinium Ions." *Molecules* 26.6 (2021): 1774. [[Link](#)]

Need Custom Synthesis?

BenchChem offers custom synthesis for rare earth carbides and specific isotopic labeling.

Email: info@benchchem.com or [Request Quote Online](#).

Sources

- 1. pubs.rsc.org [pubs.rsc.org]
- 2. pubs.acs.org [pubs.acs.org]
- 3. mdpi.com [mdpi.com]
- 4. Preparation of Stable Bicyclic Aziridinium Ions and Their Ring-Opening for the Synthesis of Azaheterocycles - PMC [[pmc.ncbi.nlm.nih.gov](https://pubmed.ncbi.nlm.nih.gov/)]
- 5. Alkylative Aziridine Ring-Opening Reactions - PMC [[pmc.ncbi.nlm.nih.gov](https://pubmed.ncbi.nlm.nih.gov/)]
- 6. mdpi.com [mdpi.com]
- 7. [Frontiers | Regioselective ring opening of aziridine for synthesizing azaheterocycle](https://www.frontiersin.org) [[frontiersin.org](https://www.frontiersin.org)]

- [8. Recent updates and future perspectives in aziridine synthesis and reactivity - PMC \[pmc.ncbi.nlm.nih.gov\]](#)
- [9. ouci.dntb.gov.ua \[ouci.dntb.gov.ua\]](#)
- [10. Biocatalytic One-Carbon Ring Expansion of Aziridines to Azetidines via a Highly Enantioselective \[1,2\]-Stevens Rearrangement - PMC \[pmc.ncbi.nlm.nih.gov\]](#)
- [11. Recent advances in synthetic facets of immensely reactive azetidines - RSC Advances \(RSC Publishing\) DOI:10.1039/C7RA08884A \[pubs.rsc.org\]](#)
- To cite this document: BenchChem. [Technical Support Center: Ring-Expansion of Aziridines to Azetidines]. BenchChem, [2026]. [Online PDF]. Available at: [\[https://www.benchchem.com/product/b1321207/docs#technical-support-center-ring-expansion-of-aziridines-to-azetidines\]](https://www.benchchem.com/product/b1321207/docs#technical-support-center-ring-expansion-of-aziridines-to-azetidines)

Disclaimer & Data Validity:

The information provided in this document is for Research Use Only (RUO) and is strictly not intended for diagnostic or therapeutic procedures. While BenchChem strives to provide accurate protocols, we make no warranties, express or implied, regarding the fitness of this product for every specific experimental setup.

Technical Support: The protocols provided are for reference purposes. Unsure if this reagent suits your experiment?

Need Industrial/Bulk Grade? [Request Custom Synthesis Quote](#)

BenchChem

Our mission is to be the trusted global source of essential and advanced chemicals, empowering scientists and researchers to drive progress in science and industry.

Contact

Address: 3281 E Guasti Rd
Ontario, CA 91761, United States
Phone: (601) 213-4426
Email: info@benchchem.com

Contact our Ph.D. Support Team for a compatibility check