

Spectroscopic Characterization of Novel Isoquinoline Derivatives: A Senior Application Scientist's Guide

Author: BenchChem Technical Support Team. **Date:** May 2026

Compound of Interest

Compound Name: *Isoquinoline-7-carbonitrile*

CAS No.: 223671-92-9

Cat. No.: B1321890

[Get Quote](#)

Foreword: Beyond the Spectrum

The isoquinoline scaffold is a cornerstone in medicinal chemistry, forming the structural basis for a vast array of natural alkaloids and synthetic compounds with significant biological activities, including antihypertensive, anti-inflammatory, and anti-tumor properties[1]. The journey from a promising synthetic route to a fully validated novel isoquinoline derivative is paved with analytical challenges. A mere collection of spectra is insufficient; true structural elucidation lies in a synergistic interpretation of data, where each technique provides a unique piece of a complex molecular puzzle.

This guide is structured to mirror the logical workflow of structural determination. We will not follow a rigid template but rather a narrative that begins with establishing the molecular formula, proceeds to map the intricate proton-carbon framework, and concludes by confirming functional groups and electronic properties. As your virtual Senior Application Scientist, I will not only detail the protocols but also illuminate the rationale behind each experimental choice, ensuring a robust and self-validating analytical strategy.

Part 1: The Foundational Step - Molecular Weight and Formula Determination via Mass Spectrometry (MS)

The first question for any novel compound is fundamental: "What is its mass?" High-Resolution Mass Spectrometry (HRMS) is the definitive tool for answering this, providing the elemental composition and, consequently, the molecular formula.

Expertise & Causality: Choosing the Right Ionization Technique

For most novel isoquinoline derivatives, which possess a basic nitrogen atom, Electrospray Ionization (ESI) in positive ion mode is the technique of choice.^{[2][3]} The nitrogen atom is readily protonated, yielding a strong signal for the protonated molecule $[M+H]^+$. This "soft" ionization technique minimizes in-source fragmentation, preserving the crucial molecular ion for accurate mass determination.

Protocol 1: HRMS Analysis via ESI-Quadrupole Time-of-Flight (Q-TOF)

- Sample Preparation: Dissolve the purified novel derivative in a suitable solvent (e.g., methanol or acetonitrile) to a concentration of approximately 1 mg/mL. Prepare a serial dilution to a final concentration of 1-10 $\mu\text{g/mL}$ in 50:50 acetonitrile:water with 0.1% formic acid. The acid ensures efficient protonation.
- Instrumentation Setup (ESI+):
 - Infusion: Directly infuse the sample solution at a flow rate of 5-10 $\mu\text{L/min}$.
 - Ion Source Parameters: Set the capillary voltage to ~ 4.5 kV and the heated capillary temperature to $\sim 200^\circ\text{C}$.^[3]
 - Mass Analyzer (TOF): Calibrate the instrument using a known standard immediately before the run to ensure high mass accuracy (< 5 ppm). Acquire data in a mass range appropriate for the expected molecular weight (e.g., m/z 100-1000).

- Data Analysis:
 - Identify the most abundant ion in the spectrum, which should correspond to $[M+H]^+$.
 - Utilize the instrument's software to calculate the elemental composition based on the exact mass measured. Compare this to the theoretical mass of the proposed structure.

Trustworthiness: Interpreting Tandem MS (MS/MS) Fragmentation

Beyond the molecular formula, MS/MS provides vital structural clues. By isolating the $[M+H]^+$ ion and subjecting it to collision-induced dissociation (CID), we can observe characteristic fragmentation patterns that act as a structural fingerprint.

A systematic study of 66 different isoquinoline alkaloids revealed key fragmentation behaviors. [2][4][5] For instance, the loss of substituents on the nitrogen atom is a common pathway. [2][4] Derivatives with vicinal methoxy and hydroxy groups often exhibit a characteristic neutral loss of methanol (CH_3OH). [2][5] Understanding these established patterns allows for a deeper level of structural confirmation. [4]

Part 2: Mapping the Atomic Framework with Nuclear Magnetic Resonance (NMR) Spectroscopy

NMR is the most powerful technique for the de novo structural elucidation of organic molecules. For isoquinoline derivatives, a combination of 1D (1H , ^{13}C) and 2D NMR experiments is essential for unambiguous assignment of all protons and carbons. [6]

Workflow for Complete NMR Structural Elucidation

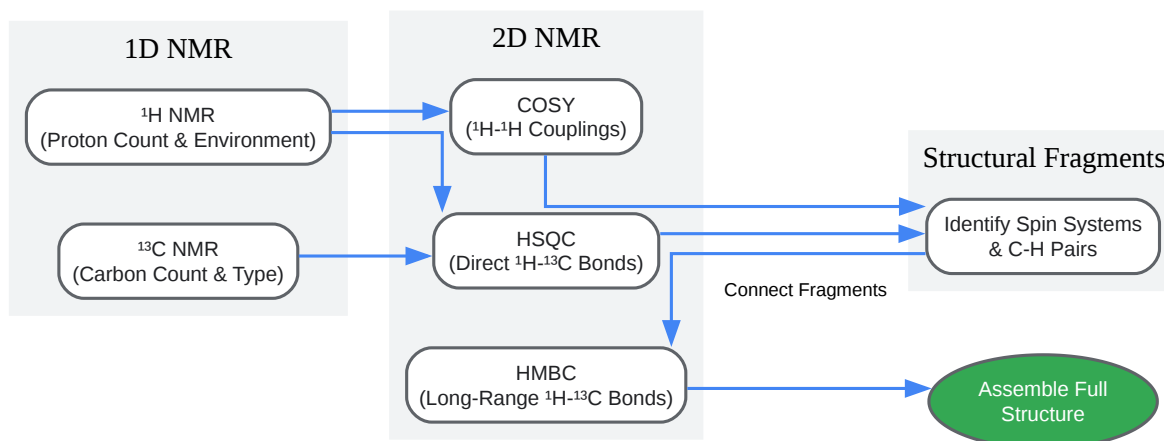

[Click to download full resolution via product page](#)

Caption: Integrated NMR workflow for structural elucidation.

Protocol 2: Comprehensive NMR Analysis

- **Sample Preparation:** Dissolve 5-10 mg of the purified compound in ~0.6 mL of a deuterated solvent (e.g., CDCl_3 , DMSO-d_6). Causality Note: Solvent choice is critical. Some 3,4-dihydroisoquinolines have shown anomalous ^1H NMR spectra with extreme line broadening in CDCl_3 , which can be resolved by adding a small amount of acid or changing the solvent. [7]
- **1D NMR Acquisition:**
 - ^1H NMR: Acquire a standard proton spectrum. Integrate all signals to determine relative proton counts.
 - ^{13}C NMR: Acquire a proton-decoupled carbon spectrum to identify the number of unique carbon environments. A DEPT-135 experiment can be run to differentiate between CH/CH_3 (positive) and CH_2 (negative) signals.
- **2D NMR Acquisition:**

- COSY (Correlation Spectroscopy): This experiment identifies protons that are spin-spin coupled (typically through 2-3 bonds), revealing neighboring protons and helping to trace out aliphatic chains or aromatic spin systems.[\[6\]](#)[\[8\]](#)
- HSQC (Heteronuclear Single Quantum Coherence): This spectrum correlates each proton with the carbon it is directly attached to, definitively linking the ^1H and ^{13}C assignments.[\[8\]](#)[\[9\]](#)
- HMBC (Heteronuclear Multiple Bond Correlation): This is arguably the most crucial experiment for connecting disparate structural fragments. It shows correlations between protons and carbons over 2-4 bonds, allowing for the connection of substituents to the isoquinoline core and the unambiguous placement of groups on the fused ring system.[\[6\]](#)[\[8\]](#)[\[10\]](#)

Data Interpretation: Characteristic Isoquinoline Signals

While exact shifts depend on substitution, some general ranges for the unsubstituted isoquinoline core in CDCl_3 are instructive.[\[11\]](#)

Position	¹ H Chemical Shift (δ, ppm)	¹³ C Chemical Shift (δ, ppm)
C1	9.22	152.7
C3	7.58	143.2
C4	8.50	120.6
C5	7.80	128.8
C6	7.62	127.4
C7	7.70	130.4
C8	7.95	126.6
C4a	-	135.8
C8a	-	129.1

Data adapted from
reference[11] and
SpectraBase[12].

Expertise in Action: The proton at C1 (H-1) is typically the most downfield signal due to the deshielding effect of the adjacent nitrogen atom, often appearing as a sharp singlet.[11] In contrast, the H-3 and H-4 protons form a distinct AX system. HMBC correlations from substituents (e.g., methoxy protons) to the isoquinoline carbons are essential for confirming their exact location.[10][13] For example, a correlation from a methoxy singlet at ~3.9 ppm to a carbon signal at ~148 ppm would strongly suggest a methoxy group attached to an oxygen-bearing aromatic carbon like C6 or C7.

Part 3: Functional Group and Electronic System Confirmation

While MS and NMR build the molecular skeleton, IR and UV-Vis spectroscopy provide orthogonal confirmation of functional groups and the overall electronic nature of the molecule.

Infrared (IR) Spectroscopy: Vibrational Fingerprints

IR spectroscopy is a rapid and effective method for identifying key functional groups.[11] The C=N and C=C stretching vibrations within the aromatic system of isoquinoline give rise to a series of characteristic absorption bands.[11][14]

Protocol 3: FT-IR Analysis using Attenuated Total Reflectance (ATR)

- **Sample Preparation:** Place a small amount of the solid or liquid sample directly onto the ATR crystal. No further preparation is needed.
- **Background Collection:** Acquire a background spectrum of the clean, empty ATR crystal.
- **Sample Acquisition:** Acquire the sample spectrum over a range of 4000-400 cm^{-1} with a resolution of 4 cm^{-1} . [11] Co-add 16-32 scans to improve the signal-to-noise ratio. The instrument software automatically generates the final transmittance or absorbance spectrum. [11]

Characteristic IR Bands for Isoquinoline Derivatives:

Frequency Range (cm^{-1})	Vibration	Comment
3100-3000	Aromatic C-H Stretch	Confirms the presence of the aromatic rings.
1620-1575	C=N Stretch	Characteristic of the pyridine part of the ring.[15]
1590-1450	C=C Stretch	Multiple bands confirming the aromatic skeleton.
1200-1000	C-O Stretch	Strong band if ether (e.g., methoxy) groups are present.
850-750	C-H Out-of-Plane Bend	Pattern can give clues about the substitution on the benzene ring.

Data compiled from references[9][11][15][16].

UV-Visible (UV-Vis) Spectroscopy: Probing the π -System

UV-Vis spectroscopy provides information about the electronic transitions within the conjugated π -system of the isoquinoline core. The position (λ_{\max}) and intensity of absorption bands are sensitive to the nature and position of substituents as well as the solvent.[17]

Protocol 4: UV-Vis Spectral Analysis

- **Sample Preparation:** Prepare a dilute solution of the compound in a UV-grade solvent (e.g., ethanol or cyclohexane). The concentration should be adjusted to give a maximum absorbance between 0.1 and 1.0.[11]
- **Baseline Correction:** Use a cuvette filled with the pure solvent to record a baseline.
- **Spectrum Acquisition:** Record the absorption spectrum over a range of approximately 200-400 nm.[15]
- **Data Analysis:** Identify the wavelengths of maximum absorbance (λ_{\max}).

Isoquinoline itself typically shows three main absorption bands, and the spectra of derivatives are often similar, though shifts are expected.[18] For example, a study of 5-substituted isoquinolines in benzene showed three absorption maxima for each derivative.[18] The solvent can play a significant role; a study on indenoisoquinolines demonstrated a notable dependence of relative absorption intensities on solvent polarity.[17]

Conclusion: A Synergistic Approach to Certainty

The structural elucidation of a novel isoquinoline derivative is not a linear process but an iterative cycle of hypothesis and verification. HRMS provides the elemental formula. 1D and 2D NMR piece together the atomic connectivity. FT-IR confirms the expected functional groups, and UV-Vis spectroscopy validates the electronic nature of the conjugated system. Each piece of data, when interpreted with an understanding of the underlying chemical principles and supported by the vast body of literature, contributes to the final, unambiguous structural assignment. This integrated, multi-technique approach ensures the highest level of scientific integrity and trustworthiness in drug discovery and development.

Overall Characterization Workflow

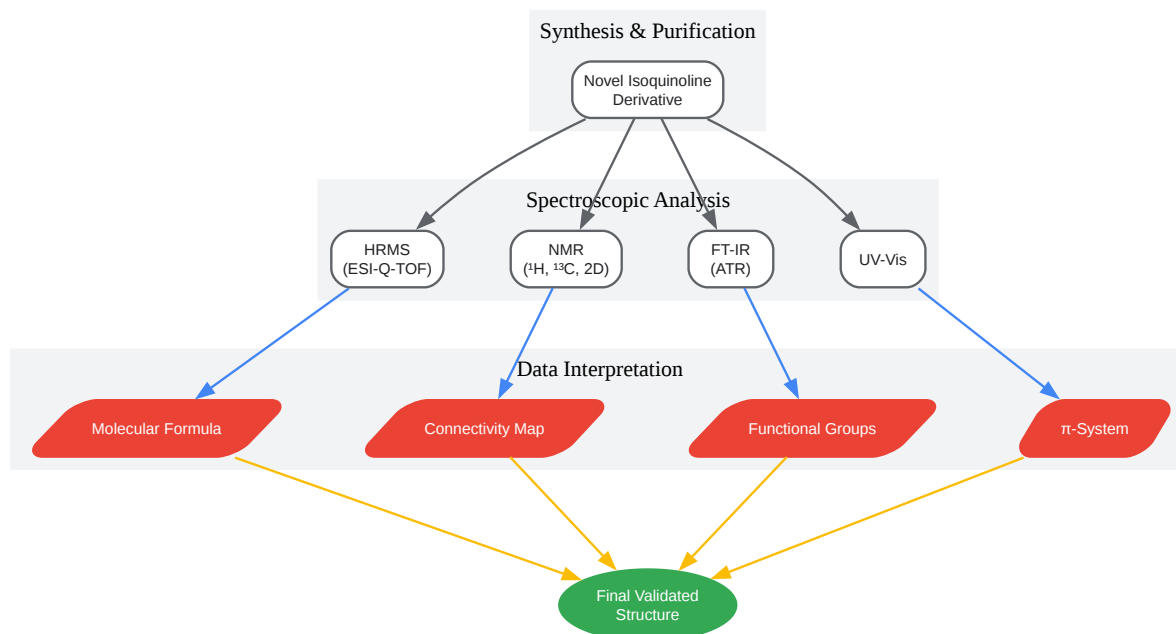

[Click to download full resolution via product page](#)

Caption: A synergistic workflow for spectroscopic characterization.

References

- Integrative Approach Based on Leaf Spray Mass Spectrometry, HPLC-DAD-MS/MS, and NMR for Comprehensive Characterization of Isoquinoline-Derived Alkaloids in Leaves of *Onychopetalum amazonicum* R. E. Fr. SciELO. Available from: [\[Link\]](#)
- Anomalous ¹H NMR spectra of 3,4-dihydroisoquinolines and related compounds. Proceedings of the Indian Academy of Sciences - Chemical Sciences. Available from: [\[Link\]](#)

- Investigation of fragmentation behaviours of isoquinoline alkaloids by mass spectrometry combined with computational chemistry. ResearchGate. Available from: [\[Link\]](#)
- Investigation of fragmentation behaviours of isoquinoline alkaloids by mass spectrometry combined with computational chemistry. PubMed. Available from: [\[Link\]](#)
- Analysis of isoquinoline alkaloids in medicinal plants by capillary electrophoresis-mass spectrometry. PubMed. Available from: [\[Link\]](#)
- Investigation of fragmentation behaviours of isoquinoline alkaloids by mass spectrometry combined with computational chemistry. NIH National Center for Biotechnology Information. Available from: [\[Link\]](#)
- Application of Mass Spectrometry in the Study of Some Isoquinoline Alkaloids. MacSphere. Available from: [\[Link\]](#)
- What are the ^1H NMR chemical shift values for 6,7-methoxyisoquinoline-1-carboxylic acid? Google AI Search.
- Recorded UV-Visible spectra of 5-substituted isoquinolines in benzene. ResearchGate. Available from: [\[Link\]](#)
- Dynamic NMR and Ab Initio Studies of Exchange Between Rotamers of Derivatives of octahydrofuro[3,4-f]isoquinoline-7(1H)-carboxylate and tetrahydro-2,5,6(1H)-isoquinolinetricarboxylate. PubMed. Available from: [\[Link\]](#)
- Synthesis and Fluorescent Properties of Novel Isoquinoline Derivatives. MDPI. Available from: [\[Link\]](#)
- Synthesis and Characterization of Novel Functionally Substituted Planar Pyrimidothienisoquinolines and Nonplanar (3aR, 4S, 9aS)-pyrazolo[3,4-g]isoquinolines. ACS Omega. Available from: [\[Link\]](#)
- Synthesis Of Novel 1,2,3,4-Tetrahydro- Isoquinoline Derivatives. International Journal of Scientific & Technology Research. Available from: [\[Link\]](#)
- Synthesis and Fluorescent Properties of Novel Isoquinoline Derivatives. Semantic Scholar. Available from: [\[Link\]](#)

- 1H and 13C NMR spectral assignments and X-ray crystallography of 4,5,8,12b-TETrahydro-isoindolo[1,2-a]isoquinoline and derivatives. ResearchGate. Available from: [\[Link\]](#)
- Absorption Spectra of Heterocyclic Compounds. I. Quinolinols and Isoquinolinols. ACS Publications. Available from: [\[Link\]](#)
- Isoquinoline alkaloids: A 15N NMR and x-ray study. Part 2. ResearchGate. Available from: [\[Link\]](#)
- DFT studies and vibrational spectra of isoquinoline and 8-hydroxyquinoline. ResearchGate. Available from: [\[Link\]](#)
- Synthesis and Fluorescent Properties of Novel Isoquinoline Derivatives. PubMed. Available from: [\[Link\]](#)
- Synthesis and Investigation of Tricyclic Isoquinoline Derivatives as Antibacterial Agents. MDPI. Available from: [\[Link\]](#)
- H,H-COSY (↔) and HMBC (→) correlations of 4-methoxy2H-isoquinolin-1-one (2). ResearchGate. Available from: [\[Link\]](#)
- DFT studies and vibrational spectra of isoquinoline and 8-hydroxyquinoline. PubMed. Available from: [\[Link\]](#)
- Synthesis, Reactions and Medicinal Uses of Isoquinoline. Pharmaguideline. Available from: [\[Link\]](#)
- Isoquinoline synthesis. Química Orgánica. Available from: [\[Link\]](#)
- Novel Quinazolinone–Isoxazoline Hybrids: Synthesis, Spectroscopic Characterization, and DFT Mechanistic Study. MDPI. Available from: [\[Link\]](#)
- Synthesis of isoquinolines. Organic Chemistry Portal. Available from: [\[Link\]](#)
- Isoquinoline-1-carboxylic acid - Optional[1H NMR] - Chemical Shifts. SpectraBase. Available from: [\[Link\]](#)

- Synthesis of isoquinolines. VII. 4-Hydroxy-1,2,3,4-tetrahydroisoquinolines. ACS Publications. Available from: [\[Link\]](#)
- Ultraviolet Absorption Spectra of Some Substituted Quinolines. Google Books.
- Isoquinoline - Optional[¹³C NMR] - Chemical Shifts. SpectraBase. Available from: [\[Link\]](#)
- ¹⁹F and ¹³C GIAO-NMR chemical shifts for the identification of perfluoro-quinoline and -isoquinoline derivatives. ResearchGate. Available from: [\[Link\]](#)
- Isoquinoline. NIST Chemistry WebBook. Available from: [\[Link\]](#)
- Solvent Dependency of the UV-Vis Spectrum of Indenoisoquinolines: Role of Keto-Oxygens as Polarity Interaction Probes. PMC - PubMed Central. Available from: [\[Link\]](#)
- Common 2D (COSY, HSQC, HMBC). SDSU NMR Facility – Department of Chemistry. Available from: [\[Link\]](#)
- Isoquinoline - Optional[FTIR] - Spectrum. SpectraBase. Available from: [\[Link\]](#)
- Isoquinoline gas-phase absorption spectrum in the vacuum ultraviolet between 3.7 and 10.7 eV. New valence and Rydberg electronic states. RSC Publishing. Available from: [\[Link\]](#)

Need Custom Synthesis?

BenchChem offers custom synthesis for rare earth carbides and specific isotopic labeling.

Email: info@benchchem.com or [Request Quote Online](#).

Sources

1. [mdpi.com \[mdpi.com\]](#)
2. Investigation of fragmentation behaviours of isoquinoline alkaloids by mass spectrometry combined with computational chemistry - PubMed [[pubmed.ncbi.nlm.nih.gov](#)]
3. Analysis of isoquinoline alkaloids in medicinal plants by capillary electrophoresis-mass spectrometry - PubMed [[pubmed.ncbi.nlm.nih.gov](#)]
4. [researchgate.net \[researchgate.net\]](#)

- 5. Investigation of fragmentation behaviours of isoquinoline alkaloids by mass spectrometry combined with computational chemistry - PMC [[pmc.ncbi.nlm.nih.gov](https://pubmed.ncbi.nlm.nih.gov)]
- 6. [researchgate.net](https://www.researchgate.net) [[researchgate.net](https://www.researchgate.net)]
- 7. ias.ac.in [ias.ac.in]
- 8. 7) Common 2D (COSY, HSQC, HMBC) | SDSU NMR Facility – Department of Chemistry [nmr.sdsu.edu]
- 9. Novel Quinazolinone–Isoxazoline Hybrids: Synthesis, Spectroscopic Characterization, and DFT Mechanistic Study | MDPI [[mdpi.com](https://www.mdpi.com)]
- 10. [researchgate.net](https://www.researchgate.net) [[researchgate.net](https://www.researchgate.net)]
- 11. pdf.benchchem.com [pdf.benchchem.com]
- 12. [spectrabase.com](https://www.spectrabase.com) [[spectrabase.com](https://www.spectrabase.com)]
- 13. What are the ¹H NMR chemical shift values for 6,7-methoxyisoquinoline-1-c.. [askfilo.com]
- 14. DFT studies and vibrational spectra of isoquinoline and 8-hydroxyquinoline - PubMed [pubmed.ncbi.nlm.nih.gov]
- 15. [researchgate.net](https://www.researchgate.net) [[researchgate.net](https://www.researchgate.net)]
- 16. pubs.acs.org [pubs.acs.org]
- 17. Solvent Dependency of the UV-Vis Spectrum of Indenoisoquinolines: Role of Keto-Oxygens as Polarity Interaction Probes - PMC [[pmc.ncbi.nlm.nih.gov](https://pubmed.ncbi.nlm.nih.gov)]
- 18. [researchgate.net](https://www.researchgate.net) [[researchgate.net](https://www.researchgate.net)]
- To cite this document: BenchChem. [Spectroscopic Characterization of Novel Isoquinoline Derivatives: A Senior Application Scientist's Guide]. BenchChem, [2026]. [Online PDF]. Available at: [<https://www.benchchem.com/product/b1321890/docs#spectroscopic-characterization-of-novel-isoquinoline-derivatives-a-senior-application-scientist-s-guide>]

Disclaimer & Data Validity:

The information provided in this document is for Research Use Only (RUO) and is strictly not intended for diagnostic or therapeutic procedures. While BenchChem strives to provide accurate protocols, we make no warranties, express or implied, regarding the fitness of this product for every specific experimental setup.

Technical Support: The protocols provided are for reference purposes. Unsure if this reagent suits your experiment?

Need Industrial/Bulk Grade? [Request Custom Synthesis Quote](#)

BenchChem

Our mission is to be the trusted global source of essential and advanced chemicals, empowering scientists and researchers to drive progress in science and industry.

Contact

Address: 3281 E Guasti Rd
Ontario, CA 91761, United States
Phone: (601) 213-4426
Email: info@benchchem.com

[Contact our Ph.D. Support Team for a compatibility check](#)