

# "2-(2,4-Dibromophenoxy)acetonitrile" synthesis and characterization

**Author:** BenchChem Technical Support Team. **Date:** May 2026

## Compound of Interest

Compound Name:	2-(2,4-Dibromophenoxy)acetonitrile
CAS No.:	60758-90-9
Cat. No.:	B1321457

[Get Quote](#)

An In-depth Technical Guide to the Synthesis and Characterization of **2-(2,4-Dibromophenoxy)acetonitrile**

## Abstract

This technical guide provides a comprehensive framework for the synthesis and detailed characterization of **2-(2,4-dibromophenoxy)acetonitrile**, a halogenated aromatic ether of interest in medicinal chemistry and materials science. The primary synthetic route detailed is the Williamson ether synthesis, a robust and widely applicable method for forming ether linkages.<sup>[1][2][3]</sup> This document offers a step-by-step protocol, an exploration of the underlying reaction mechanism, and key optimization strategies. Furthermore, it establishes a full analytical workflow for structural verification and purity assessment, employing Nuclear Magnetic Resonance (NMR) spectroscopy, Fourier-Transform Infrared (FT-IR) spectroscopy, and Mass Spectrometry (MS). This guide is intended for researchers, chemists, and drug development professionals requiring a practical and scientifically grounded approach to the preparation and validation of this compound.

## Introduction and Scientific Context

**2-(2,4-Dibromophenoxy)acetonitrile** belongs to the class of phenoxyacetonitrile derivatives. These scaffolds are significant in agrochemical and pharmaceutical research, with related structures exhibiting herbicidal and antifungal properties.[4] The introduction of bromine atoms onto the phenyl ring can significantly modulate a molecule's lipophilicity, metabolic stability, and binding affinity to biological targets, making **2-(2,4-dibromophenoxy)acetonitrile** a valuable intermediate for library synthesis and structure-activity relationship (SAR) studies.

The molecular structure consists of a 2,4-dibromophenol moiety linked via an ether oxygen to an acetonitrile group. The reliable synthesis and unambiguous characterization of this molecule are paramount for its application in further research endeavors.

Molecular Information:

- Chemical Formula: C<sub>8</sub>H<sub>5</sub>Br<sub>2</sub>NO
- Molecular Weight: 290.94 g/mol [5]
- CAS Number: 31254-63-6

## Synthesis via Williamson Ether Synthesis

The most direct and efficient method for preparing **2-(2,4-dibromophenoxy)acetonitrile** is the Williamson ether synthesis. This reaction proceeds via a bimolecular nucleophilic substitution (S<sub>N</sub>2) mechanism.[3] The core of the reaction involves the deprotonation of a weakly acidic phenol (2,4-dibromophenol) to form a potent nucleophile, the phenoxide ion. This phenoxide then attacks an alkyl halide, in this case, a haloacetonitrile, to form the desired ether product.[3] [6]

## Reaction Mechanism and Rationale

- Deprotonation: A base, such as potassium carbonate (K<sub>2</sub>CO<sub>3</sub>), deprotonates the hydroxyl group of 2,4-dibromophenol. Phenols are significantly more acidic than aliphatic alcohols, allowing for the use of moderately strong bases.
- Nucleophilic Attack: The resulting 2,4-dibromophenoxide anion acts as the nucleophile. It attacks the electrophilic methylene carbon of the haloacetonitrile (e.g., bromoacetonitrile).

This attack occurs from the backside relative to the leaving group (the halogen), which is characteristic of an S<sub>N</sub>2 reaction.[2]

- Product Formation: The carbon-halogen bond breaks, the leaving group is displaced, and the new carbon-oxygen bond is formed, yielding **2-(2,4-dibromophenoxy)acetonitrile**.

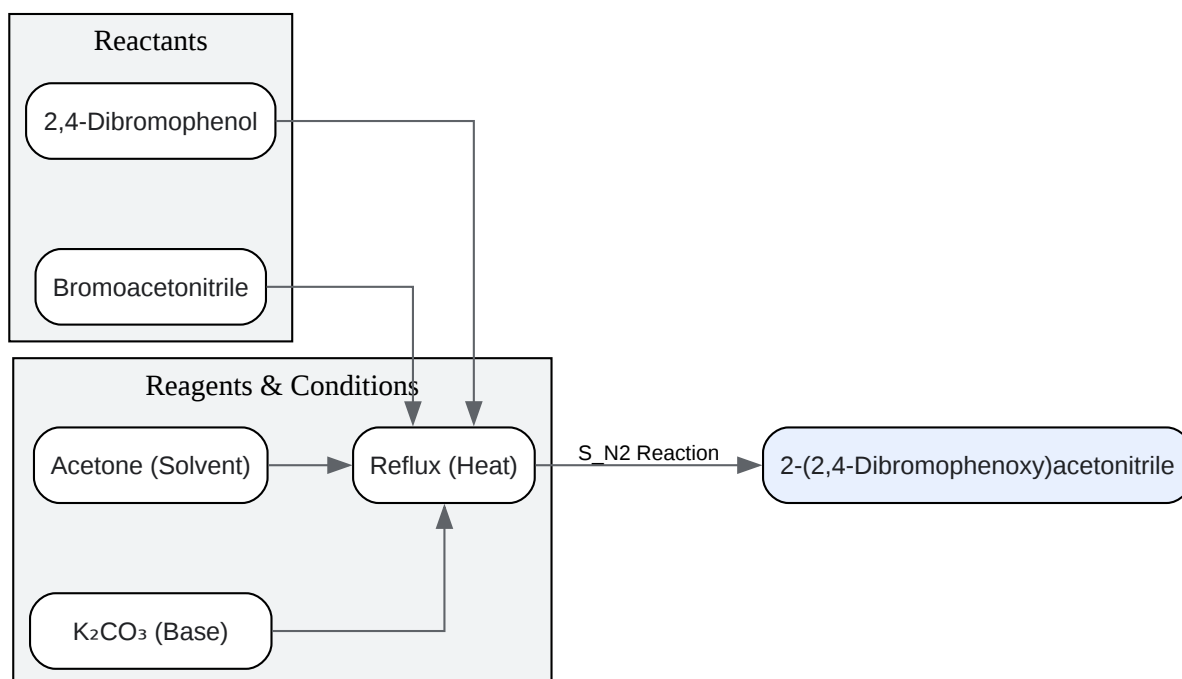

[Click to download full resolution via product page](#)

Caption: Williamson Ether Synthesis Workflow.

## Experimental Protocol

Safety Precautions: Haloacetonitriles are toxic and lachrymatory.[7] All operations must be conducted in a well-ventilated chemical fume hood with appropriate personal protective equipment (PPE), including safety goggles, lab coat, and chemical-resistant gloves.[8][9]

Reagents and Materials:

- 2,4-Dibromophenol (1.0 eq)
- Bromoacetonitrile (1.1 eq)
- Anhydrous Potassium Carbonate ( $K_2CO_3$ ) (1.5 eq)
- Anhydrous Acetone (solvent)
- Diethyl ether
- Saturated sodium bicarbonate solution
- Brine (saturated NaCl solution)
- Anhydrous magnesium sulfate ( $MgSO_4$ )

Procedure:

- To a round-bottom flask equipped with a magnetic stirrer and reflux condenser, add 2,4-dibromophenol (1.0 eq) and anhydrous acetone. Stir until the solid is fully dissolved.
- Add anhydrous potassium carbonate (1.5 eq) to the solution. Stir the resulting suspension at room temperature for 30 minutes to facilitate phenoxide formation.
- Add bromoacetonitrile (1.1 eq) dropwise to the reaction mixture.<sup>[10]</sup>
- Heat the reaction mixture to reflux (approx. 56°C for acetone) and maintain for 4-6 hours.
- Monitor the reaction progress by Thin Layer Chromatography (TLC) until the starting phenol spot is consumed.
- Upon completion, cool the mixture to room temperature.
- Filter the mixture through a pad of Celite to remove the inorganic salts (KBr and excess  $K_2CO_3$ ).<sup>[10]</sup> Wash the filter cake with a small amount of acetone.
- Combine the filtrates and concentrate under reduced pressure to yield the crude product.
- Dissolve the crude residue in diethyl ether and transfer to a separatory funnel.

- Wash the organic layer sequentially with saturated sodium bicarbonate solution (1x), water (1x), and brine (1x).[10]
- Dry the organic layer over anhydrous magnesium sulfate, filter, and concentrate under reduced pressure to afford the crude **2-(2,4-dibromophenoxy)acetonitrile**.
- Purify the product via column chromatography on silica gel (e.g., using a hexane/ethyl acetate gradient) or recrystallization to obtain the pure compound.[11]

## Causality and Optimization Insights

- **Choice of Halide:** Bromoacetonitrile is generally more reactive than chloroacetonitrile due to bromide being a better leaving group. Using bromoacetonitrile can lead to higher yields and shorter reaction times.[10]
- **Solvent System:** Polar aprotic solvents like acetone or acetonitrile are ideal. They effectively solvate the potassium cation while leaving the phenoxide nucleophile relatively unsolvated, thereby increasing its reactivity and favoring the desired O-alkylation.[10][12]
- **Anhydrous Conditions:** The presence of water can protonate the phenoxide, reducing its nucleophilicity and potentially leading to lower yields. Therefore, using anhydrous reagents and solvents is critical.[10]

## Structural Characterization and Validation

Unambiguous characterization is essential to confirm the identity and purity of the synthesized product. A combination of spectroscopic techniques provides a complete structural profile.

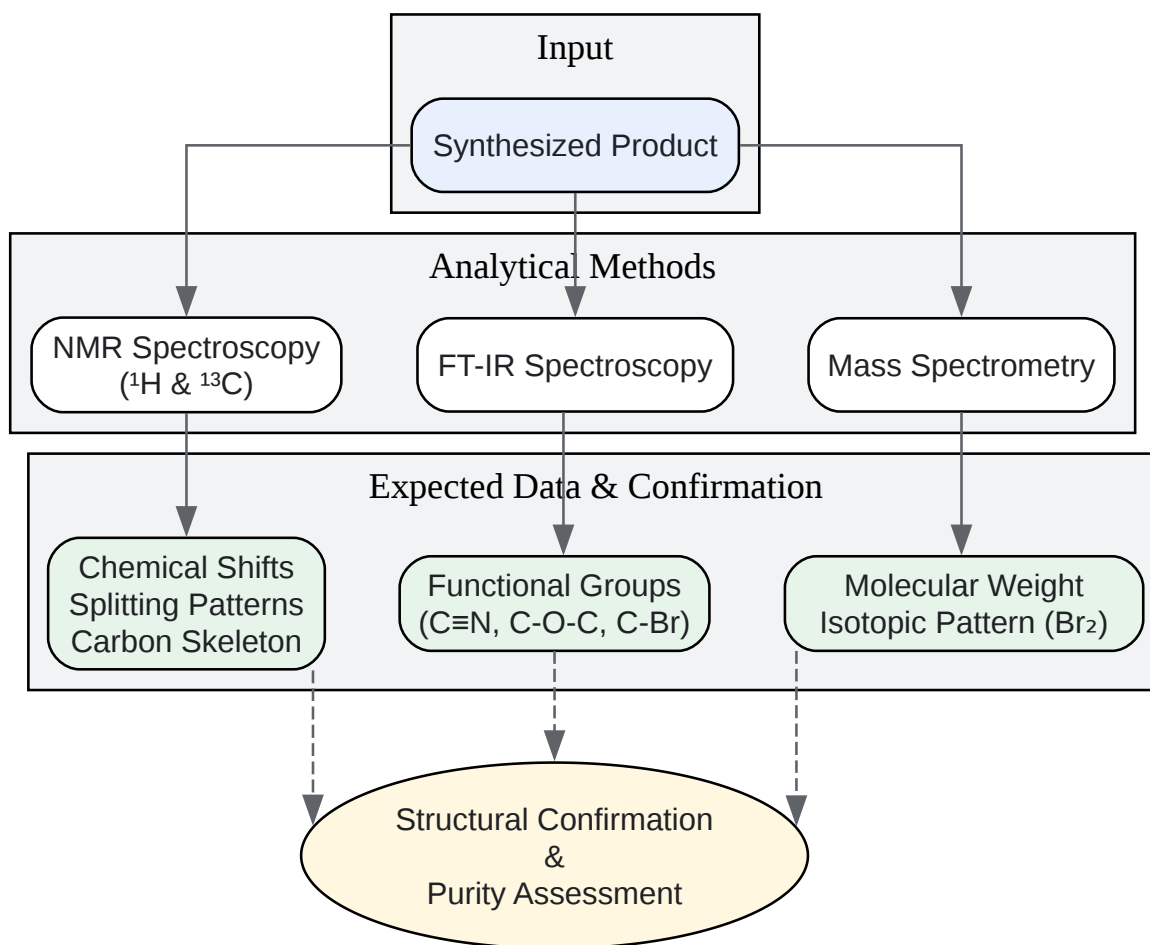

[Click to download full resolution via product page](#)

Caption: Analytical Workflow for Product Characterization.

## Nuclear Magnetic Resonance (NMR) Spectroscopy

NMR spectroscopy is the most powerful tool for elucidating the precise molecular structure. Spectra should be recorded in a deuterated solvent such as CDCl<sub>3</sub> or DMSO-d<sub>6</sub>.

**<sup>1</sup>H NMR - Predicted Data**

Chemical Shift (δ, ppm)

~7.8

~7.4

~7.0

~5.0

**<sup>13</sup>C NMR - Predicted Data**

Chemical Shift (δ, ppm)

~150-155

~135, ~132, ~125

~118, ~115

~115

~55-60

Note: Predicted chemical shifts are estimates and may vary based on solvent and experimental conditions.

## Fourier-Transform Infrared (FT-IR) Spectroscopy

FT-IR spectroscopy is used to identify the key functional groups present in the molecule.

## FT-IR - Predicted Data

Frequency (cm<sup>-1</sup>)

~2250 - 2260

~1250 - 1280

~1030 - 1050

~3050 - 3100

~2880 - 2950

~550 - 650

The presence of a sharp, distinct peak around 2255 cm<sup>-1</sup> is a strong indicator of the nitrile group and successful incorporation of the acetonitrile moiety.[\[13\]](#)[\[14\]](#)

## Mass Spectrometry (MS)

Mass spectrometry confirms the molecular weight of the compound. Due to the presence of two bromine atoms, which have two major isotopes (<sup>79</sup>Br and <sup>81</sup>Br) in approximately a 1:1 natural abundance, the molecular ion peak will exhibit a characteristic triplet pattern.

- Expected Molecular Ion (M<sup>+</sup>) Pattern:
  - m/z [M]<sup>+</sup>: Corresponding to (C<sub>8</sub>H<sub>5</sub><sup>79</sup>Br<sub>2</sub>NO)<sup>+</sup>
  - m/z [M+2]<sup>+</sup>: Corresponding to (C<sub>8</sub>H<sub>5</sub><sup>79</sup>Br<sup>81</sup>BrNO)<sup>+</sup>
  - m/z [M+4]<sup>+</sup>: Corresponding to (C<sub>8</sub>H<sub>5</sub><sup>81</sup>Br<sub>2</sub>NO)<sup>+</sup>
- Relative Intensity: The expected intensity ratio for this triplet will be approximately 1:2:1. This distinctive isotopic signature is definitive proof of a dibrominated compound.[\[15\]](#)[\[16\]](#)

## Conclusion

This guide outlines a reliable and field-proven methodology for the synthesis and characterization of **2-(2,4-dibromophenoxy)acetonitrile**. Adherence to the detailed Williamson

ether synthesis protocol, coupled with a rigorous analytical workflow employing NMR, FT-IR, and MS, will ensure the production of a high-purity compound suitable for advanced research applications. The principles and troubleshooting insights provided herein are designed to empower researchers to confidently prepare and validate this and structurally related molecules.

## References

- The Williamson Ether Synthesis. University of Colorado Boulder.
- SAFETY DATA SHEET - TCI Chemicals. TCI Chemicals.
- SAFETY DATA SHEET - Fisher Scientific. Fisher Scientific.
- Williamson Ether Synthesis - Chemistry Steps. Chemistry Steps.
- The Williamson Ether Synthesis - Master Organic Chemistry. Master Organic Chemistry.
- Williamson ether synthesis: simple mechanism, 3 examples - Chemistry Notes. Chemistry Notes.
- Williamson ether synthesis - Wikipedia. Wikipedia.
- **2-(2,4-Dibromophenoxy)acetonitrile** | SCBT - Santa Cruz Biotechnology. Santa Cruz Biotechnology.
- Semisynthesis and Cytotoxic Evaluation of an Ether Analogue Library Based on a Polyhalogenated Diphenyl Ether Scaffold Isolated from a Lamellodysidea Sponge - PMC.
- Dibromoacetonitrile SDS, 3252-43-5 Safety D
- A Comparative Analysis of the Biological Activities of 2-(4-Chlorophenoxy)acetonitrile and its Bromo Analog - Benchchem. BenchChem.
- Technical Support Center: Synthesis of 2-(4-Bromo-3-methoxyphenyl)acetonitrile - Benchchem. BenchChem.
- Technical Support Center: Optimizing Reaction Conditions for 2-(4-Chlorophenoxy)
- Quantitative <sup>1</sup>H-NMR analysis reveals steric and electronic effects on the substrate specificity of benzoate dioxygenase in *Ralstonia eutropha* B9 - PMC.
- Synthesis of D. 2-(4-Bromophenethyl)-phenylacetonitrile - PrepChem.com. PrepChem.com.
- (PDF) Overview of acetonitrile: Physicochemical properties, applications and clinical aspects.
- Far IR-spectra of acetonitrile[17] (spectral resolution: 0.25 cm<sup>-1</sup>)... - ResearchGate. ResearchGate.
- Anomalous Infrared Intensity Behavior of Acetonitrile Diffused into UiO-67 - Temple University. Temple University ScholarShare.
- Advanced NMR techniques for structural characterization of heterocyclic structures - ESA-IPB. Polytechnic Institute of Bragança.

- Analysis of Polybrominated Diphenyl Ethers and Novel Brominated Flame Retardants in Soil Using the Agilent 7000 Triple Quadrupole GC/MS. Agilent.
- Acetonitrile, dibromo- - the NIST WebBook - National Institute of Standards and Technology. NIST.
- Pentabromodiphenyl ethers | C<sub>12</sub>H<sub>5</sub>Br<sub>5</sub>O | CID 36159 - PubChem. PubChem.

### Need Custom Synthesis?

BenchChem offers custom synthesis for rare earth carbides and specific isotopic labeling.

Email: [info@benchchem.com](mailto:info@benchchem.com) or [Request Quote Online](#).

## Sources

- [1. Williamson Ether Synthesis - Chemistry Steps \[chemistrysteps.com\]](#)
- [2. masterorganicchemistry.com \[masterorganicchemistry.com\]](#)
- [3. Williamson ether synthesis - Wikipedia \[en.wikipedia.org\]](#)
- [4. pdf.benchchem.com \[pdf.benchchem.com\]](#)
- [5. scbt.com \[scbt.com\]](#)
- [6. chemistnotes.com \[chemistnotes.com\]](#)
- [7. fishersci.com \[fishersci.com\]](#)
- [8. tcichemicals.com \[tcichemicals.com\]](#)
- [9. echemi.com \[echemi.com\]](#)
- [10. pdf.benchchem.com \[pdf.benchchem.com\]](#)
- [11. pdf.benchchem.com \[pdf.benchchem.com\]](#)
- [12. researchgate.net \[researchgate.net\]](#)
- [13. researchgate.net \[researchgate.net\]](#)
- [14. sites.temple.edu \[sites.temple.edu\]](#)
- [15. agilent.com \[agilent.com\]](#)
- [16. Pentabromodiphenyl ethers | C<sub>12</sub>H<sub>5</sub>Br<sub>5</sub>O | CID 36159 - PubChem \[pubchem.ncbi.nlm.nih.gov\]](#)
- [17. The Williamson Ether Synthesis \[cs.gordon.edu\]](#)

- To cite this document: BenchChem. ["2-(2,4-Dibromophenoxy)acetonitrile" synthesis and characterization]. BenchChem, [2026]. [Online PDF]. Available at: [<https://www.benchchem.com/product/b1321457/docs#2-2-4-dibromophenoxy-acetonitrile-synthesis-and-characterization>]

---

### Disclaimer & Data Validity:

The information provided in this document is for Research Use Only (RUO) and is strictly not intended for diagnostic or therapeutic procedures. While BenchChem strives to provide accurate protocols, we make no warranties, express or implied, regarding the fitness of this product for every specific experimental setup.

**Technical Support:** The protocols provided are for reference purposes. Unsure if this reagent suits your experiment?

**Need Industrial/Bulk Grade?** [Request Custom Synthesis Quote](#)

## BenchChem

Our mission is to be the trusted global source of essential and advanced chemicals, empowering scientists and researchers to drive progress in science and industry.

### Contact

Address: 3281 E Guasti Rd  
Ontario, CA 91761, United States  
Phone: (601) 213-4426  
Email: [info@benchchem.com](mailto:info@benchchem.com)

[Contact our Ph.D. Support Team for a compatibility check](#)