

# Introduction: Situating 2-(Chloromethyl)-1,4-difluorobenzene in Modern Synthesis

**Author:** BenchChem Technical Support Team. **Date:** May 2026

## Compound of Interest

Compound Name: 2-(Chloromethoxy)-1,4-difluorobenzene

Cat. No.: B13204985

[Get Quote](#)

In the landscape of medicinal chemistry and materials science, the strategic incorporation of fluorine atoms into molecular scaffolds is a cornerstone of modern design. Fluorine's unique properties—high electronegativity, small atomic radius, and the ability to form strong carbon-fluorine bonds—can profoundly influence a molecule's pharmacokinetic and pharmacodynamic profile, including metabolic stability, binding affinity, and lipophilicity.<sup>[1][2]</sup> 2-(Chloromethyl)-1,4-difluorobenzene (CAS 495-07-8) emerges as a pivotal building block in this context.<sup>[3][4]</sup> It offers a difluorinated aromatic core, a feature prevalent in numerous pharmaceuticals and agrochemicals, combined with a reactive chloromethyl handle.<sup>[5]</sup> This guide provides an in-depth analysis of its chemical properties, reactivity, and safe handling protocols, designed for researchers and drug development professionals seeking to leverage this versatile intermediate.

A note on nomenclature: This guide focuses on 2-(Chloromethyl)-1,4-difluorobenzene, which features a -CH<sub>2</sub>Cl group. This is distinct from the isomeric "chloromethoxy" functionality (-OCH<sub>2</sub>Cl) and is the compound predominantly available and characterized under CAS number 495-07-8.

## Part 1: Core Physicochemical and Spectroscopic Profile

Understanding the fundamental properties of a reagent is the bedrock of successful experimental design. The data presented below has been consolidated from supplier technical specifications and chemical databases.

### Quantitative Data Summary

Property	Value	Source
CAS Number	495-07-8	[3][4]
Molecular Formula	C <sub>7</sub> H <sub>5</sub> ClF <sub>2</sub>	[3]
Molecular Weight	162.57 g/mol	[4][6]
Physical Form	Liquid	[3]
Purity (Typical)	≥98%	[3]
InChI Key	INXKTZMJFPRVAY-UHFFFAOYSA-N	[3]
Boiling Point	88 - 89 °C (for parent 1,4-difluorobenzene)	
Melting Point	-13 °C (for parent 1,4-difluorobenzene)	

Note: Specific boiling and melting point data for the title compound are not readily available in the provided search results; data for the parent 1,4-difluorobenzene are provided for context.

## Part 2: Synthesis and Chemical Reactivity

The synthetic utility of 2-(Chloromethyl)-1,4-difluorobenzene stems from the distinct reactivity of its two key structural components: the difluorinated aromatic ring and the benzylic chloride.

### Synthesis Pathway: Electrophilic Chloromethylation

The primary route to this compound is the electrophilic chloromethylation of 1,4-difluorobenzene. This class of reaction, known for introducing a chloromethyl group onto an aromatic ring, is crucial for creating versatile synthetic intermediates.[7] While specific conditions for this exact transformation are proprietary, the general mechanism involves reacting the aromatic substrate with a source of formaldehyde and hydrogen chloride, often in the presence of a Lewis acid catalyst. A common reagent for this purpose is bis(chloromethyl) ether in the presence of a strong acid.[7]

The presence of two fluorine atoms on the benzene ring significantly deactivates it towards electrophilic attack due to fluorine's strong inductive electron-withdrawing effect (-I).[8] This deactivation means that forcing conditions may be necessary for the chloromethylation to proceed efficiently.[7]

## Core Reactivity: The Benzylic Chloride Handle

The major locus of reactivity in 2-(Chloromethyl)-1,4-difluorobenzene is the benzylic chloride. The C-Cl bond is activated by the adjacent benzene ring, making it an excellent electrophilic site for nucleophilic substitution ( $S_N2$ ) reactions. This allows for the facile introduction of the 2,5-difluorobenzyl moiety onto a wide range of nucleophiles.

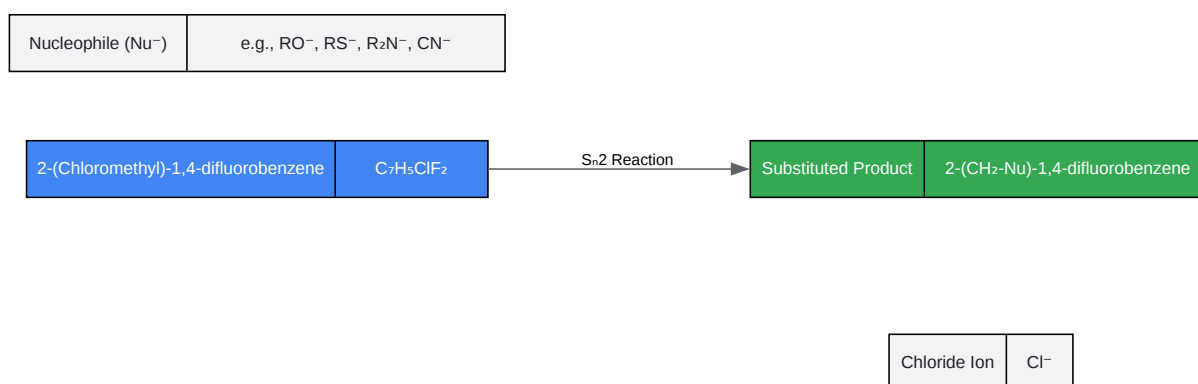

[Click to download full resolution via product page](#)

Caption: Nucleophilic substitution at the benzylic carbon.

This reactivity is the cornerstone of its utility, enabling chemists to construct more complex molecules for applications in drug discovery and materials science. For example, it can be reacted with phenols, thiols, amines, or carbanions to forge new carbon-oxygen, carbon-sulfur, carbon-nitrogen, or carbon-carbon bonds, respectively.

## Part 3: Safety, Handling, and Storage Protocols

Given its hazardous nature, strict adherence to safety protocols is non-negotiable. The information is synthesized from multiple safety data sheets (SDS).

### Hazard Identification and GHS Classification

2-(Chloromethyl)-1,4-difluorobenzene is classified as a hazardous substance.[3]

- Signal Word: Danger[3]
- Hazard Statements:
  - H227: Combustible liquid[3]
  - H290: May be corrosive to metals[3]
  - H314: Causes severe skin burns and eye damage[3]

### Experimental Workflow: Safe Handling Protocol

The following workflow must be implemented to ensure the safe handling of this reagent from procurement to disposal.

#### *Need Custom Synthesis?*

*BenchChem offers custom synthesis for rare earth carbides and specific isotopic labeling.*

*Email: [info@benchchem.com](mailto:info@benchchem.com) or [Request Quote Online](#).*

## Sources

- 1. CF<sub>2</sub>H: a fascinating group for application in drug development enabling modulation of many molecular properties - PMC [[pmc.ncbi.nlm.nih.gov](https://pubmed.ncbi.nlm.nih.gov)]
- 2. [mdpi.com](https://mdpi.com) [[mdpi.com](https://mdpi.com)]
- 3. 2-(Chloromethyl)-1,4-difluorobenzene | 495-07-8 [[sigmaaldrich.com](https://sigmaaldrich.com)]
- 4. 2-(Chloromethyl)-1,4-difluorobenzene - [[sigmaaldrich.cn](https://sigmaaldrich.cn)]
- 5. [commons.lib.jmu.edu](https://commons.lib.jmu.edu) [[commons.lib.jmu.edu](https://commons.lib.jmu.edu)]
- 6. 2-(CHLOROMETHYL)-1,3-DIFLUOROBENZENE | CAS 697-73-4 [[matrix-fine-chemicals.com](https://matrix-fine-chemicals.com)]
- 7. [notes.fluorine1.ru](https://notes.fluorine1.ru) [[notes.fluorine1.ru](https://notes.fluorine1.ru)]
- 8. [pdf.benchchem.com](https://pdf.benchchem.com) [[pdf.benchchem.com](https://pdf.benchchem.com)]
- To cite this document: BenchChem. [Introduction: Situating 2-(Chloromethyl)-1,4-difluorobenzene in Modern Synthesis]. BenchChem, [2026]. [Online PDF]. Available at: [<https://www.benchchem.com/product/b13204985/docs#introduction-situating-2-chloromethyl-1-4-difluorobenzene-in-modern-synthesis>]

---

### Disclaimer & Data Validity:

The information provided in this document is for Research Use Only (RUO) and is strictly not intended for diagnostic or therapeutic procedures. While BenchChem strives to provide accurate protocols, we make no warranties, express or implied, regarding the fitness of this product for every specific experimental setup.

**Technical Support:** The protocols provided are for reference purposes. Unsure if this reagent suits your experiment?

**Need Industrial/Bulk Grade?** [Request Custom Synthesis Quote](#)

## BenchChem

Our mission is to be the trusted global source of essential and advanced chemicals, empowering scientists and researchers to drive progress in science and industry.

### Contact

Address: 3281 E Guasti Rd  
Ontario, CA 91761, United States  
Phone: (601) 213-4426  
Email: [info@benchchem.com](mailto:info@benchchem.com)

Contact our Ph.D. Support Team for a compatibility check