

Application Note: Rapid Microwave-Assisted Synthesis of Pyridine-3-ylmethyl Propanamide

Author: BenchChem Technical Support Team. **Date:** May 2026

Compound of Interest

Compound Name: *3-amino-N-(pyridin-3-ylmethyl)propanamide*

Cat. No.: B13204966

[Get Quote](#)

For: Researchers, scientists, and drug development professionals.

Introduction: The Imperative for Accelerated Amide Bond Formation in Drug Discovery

The amide bond is a cornerstone of medicinal chemistry, present in over 25% of all pharmaceutical drugs.[1] Its remarkable stability and ability to participate in hydrogen bonding make it a privileged functional group in the design of bioactive molecules. Pyridine-containing compounds, in particular, are of significant interest due to their prevalence in numerous therapeutic agents. The synthesis of pyridine-3-ylmethyl propanamide serves as a model reaction for the rapid generation of such valuable scaffolds. Traditional methods for amide bond formation often require long reaction times, harsh conditions, and tedious purification procedures.[1] Microwave-assisted organic synthesis (MAOS) has emerged as a transformative technology, dramatically accelerating reaction rates, increasing yields, and promoting greener chemical processes.[2][3] This application note provides a detailed protocol for the efficient synthesis of pyridine-3-ylmethyl propanamide utilizing microwave irradiation, offering a significant improvement over conventional heating methods.

The primary advantages of employing microwave energy lie in its unique heating mechanism. Unlike conventional heating, which relies on thermal conductivity, microwaves directly couple with polar molecules in the reaction mixture, leading to rapid and uniform heating. This often results in cleaner reactions with fewer byproducts, simplifying purification and improving overall efficiency.[2]

Reaction Scheme & Mechanism

The microwave-assisted synthesis of pyridine-3-ylmethyl propanamide can be approached through two primary routes: the direct amidation of a carboxylic acid and an amine, or the reaction of an amine with a more reactive acyl chloride.

Scheme 1: Direct Amidation of Propanoic Acid and Pyridine-3-ylmethanamine

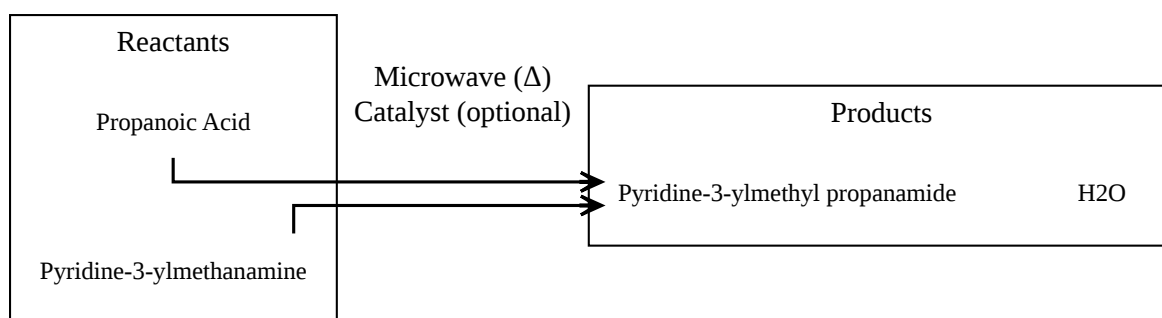

[Click to download full resolution via product page](#)

Caption: Direct amidation reaction.

Scheme 2: Acylation of Pyridine-3-ylmethanamine with Propanoyl Chloride

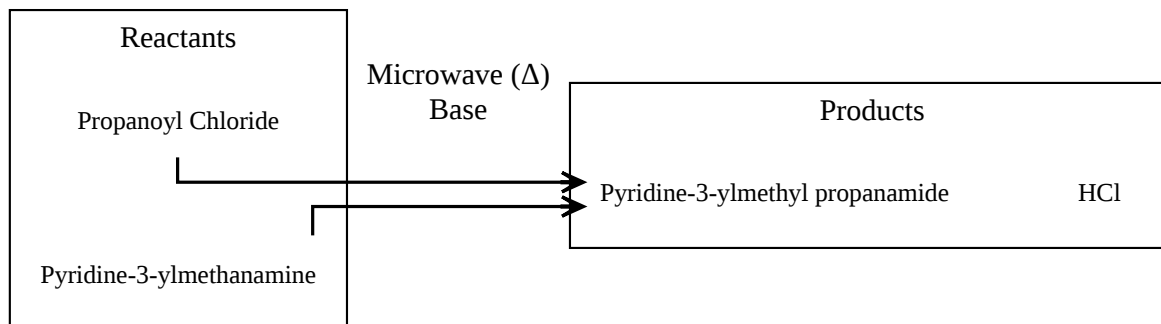

[Click to download full resolution via product page](#)

Caption: Acylation with propanoyl chloride.

The direct amidation route (Scheme 1) is often preferred for its atom economy and greener profile, avoiding the use of a halogenated reagent. However, it may require a catalyst and higher temperatures. The acylation with propanoyl chloride (Scheme 2) is typically faster and proceeds under milder conditions but generates HCl as a byproduct, necessitating the use of a base.

Detailed Protocols

Protocol 1: Microwave-Assisted Direct Amidation

This protocol is based on general procedures for microwave-assisted direct amidation of carboxylic acids and amines.[4][5]

Materials:

- Pyridine-3-ylmethanamine (1.0 eq)
- Propanoic acid (1.2 eq)
- Ceric Ammonium Nitrate (CAN) (0.02 eq) (optional, as catalyst)[4][5]
- Microwave vials (10 mL) with stir bars
- Microwave reactor

Procedure:

- To a 10 mL microwave vial equipped with a magnetic stir bar, add pyridine-3-ylmethanamine (1.0 mmol, 108.14 mg).
- Add propanoic acid (1.2 mmol, 88.9 mg, 0.09 mL).
- (Optional) Add ceric ammonium nitrate (0.02 mmol, 10.96 mg).
- Seal the vial and place it in the microwave reactor.
- Irradiate the mixture at 160°C for 30-60 minutes. The reaction progress can be monitored by TLC.
- After completion, cool the vial to room temperature.
- Dilute the reaction mixture with ethyl acetate (20 mL) and wash with saturated sodium bicarbonate solution (2 x 10 mL) and brine (10 mL).
- Dry the organic layer over anhydrous sodium sulfate, filter, and concentrate under reduced pressure to yield the crude product.
- Purify the crude product by column chromatography on silica gel (eluent: ethyl acetate/hexane gradient) to obtain pure pyridine-3-ylmethyl propanamide.

Experimental Workflow (Protocol 1):

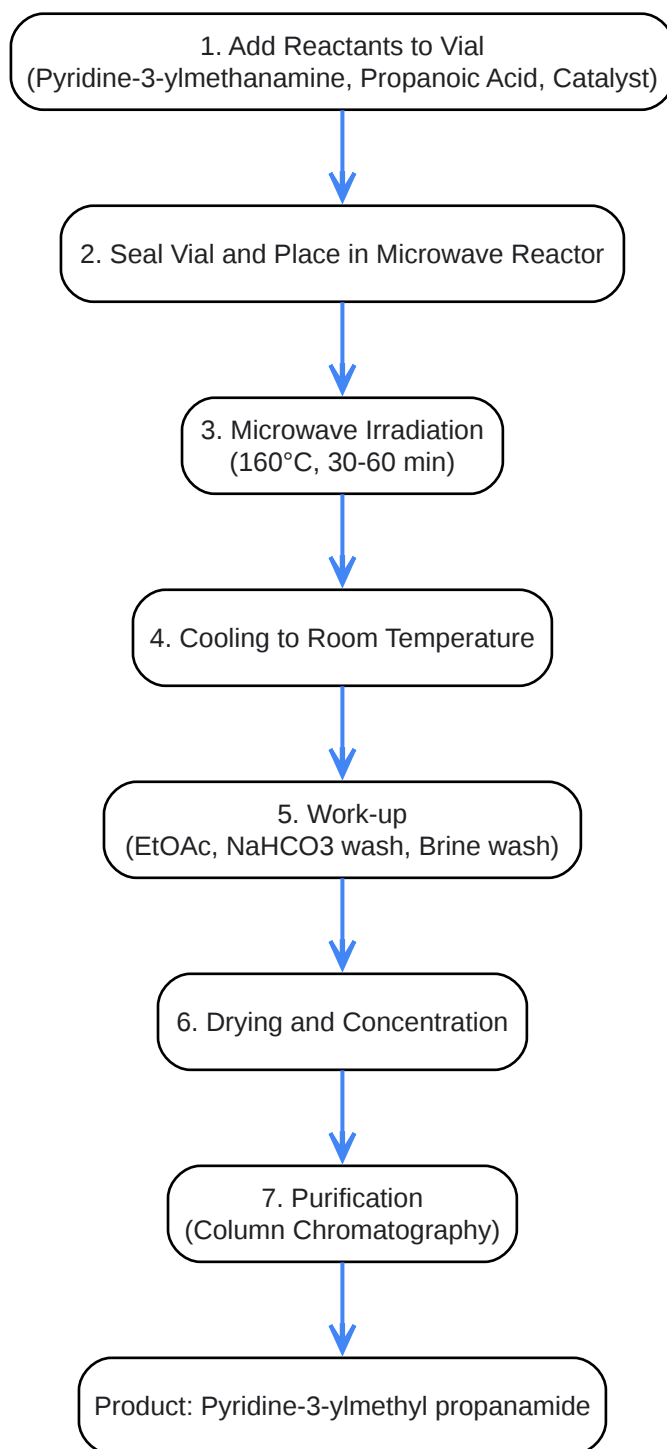

[Click to download full resolution via product page](#)

Caption: Workflow for direct amidation.

Protocol 2: Microwave-Assisted Acylation

This protocol is adapted from general procedures for the acylation of amines with acyl chlorides.[6][7]

Materials:

- Pyridine-3-ylmethanamine (1.0 eq)
- Propanoyl chloride (1.1 eq)
- Triethylamine (TEA) or Diisopropylethylamine (DIPEA) (1.5 eq)
- Dichloromethane (DCM) or Tetrahydrofuran (THF) (anhydrous)
- Microwave vials (10 mL) with stir bars
- Microwave reactor

Procedure:

- To a 10 mL microwave vial equipped with a magnetic stir bar, add pyridine-3-ylmethanamine (1.0 mmol, 108.14 mg) and anhydrous DCM (3 mL).
- Add triethylamine (1.5 mmol, 151.8 mg, 0.21 mL).
- Cool the mixture to 0°C in an ice bath.
- Slowly add propanoyl chloride (1.1 mmol, 102.0 mg, 0.09 mL).
- Seal the vial and place it in the microwave reactor.
- Irradiate the mixture at 80°C for 10-20 minutes. Monitor the reaction by TLC.
- After completion, cool the vial to room temperature.
- Quench the reaction with water (10 mL) and extract with DCM (2 x 15 mL).
- Wash the combined organic layers with saturated sodium bicarbonate solution (10 mL) and brine (10 mL).

- Dry the organic layer over anhydrous sodium sulfate, filter, and concentrate under reduced pressure.
- Purify the crude product by column chromatography on silica gel (eluent: ethyl acetate/hexane gradient) to obtain pure pyridine-3-ylmethyl propanamide.

Experimental Workflow (Protocol 2):

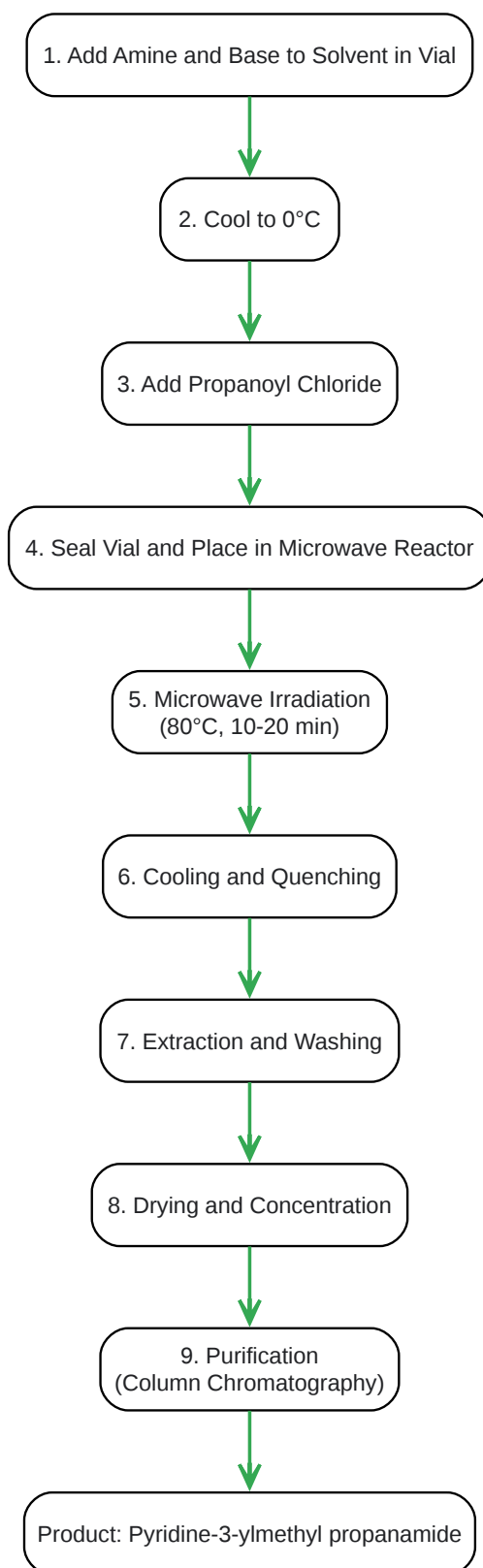

[Click to download full resolution via product page](#)

Need Custom Synthesis?

BenchChem offers custom synthesis for rare earth carbides and specific isotopic labeling.

Email: info@benchchem.com or [Request Quote Online](#).

Sources

- [1. sciforum.net \[sciforum.net\]](https://sciforum.net)
- [2. mdpi.com \[mdpi.com\]](https://mdpi.com)
- [3. Amide synthesis by acylation \[organic-chemistry.org\]](https://organic-chemistry.org)
- [4. Microwave-Assisted Catalytic Method for a Green Synthesis of Amides Directly from Amines and Carboxylic Acids - PMC \[pmc.ncbi.nlm.nih.gov\]](https://pubmed.ncbi.nlm.nih.gov/38888888/)
- [5. Microwave-Assisted Catalytic Method for a Green Synthesis of Amides Directly from Amines and Carboxylic Acids - PubMed \[pubmed.ncbi.nlm.nih.gov\]](https://pubmed.ncbi.nlm.nih.gov/38888888/)
- [6. Lab Reporter \[fishersci.it\]](https://fishersci.it)
- [7. Amine to Amide \(via Acid Chloride\) - Common Conditions \[commonorganicchemistry.com\]](https://commonorganicchemistry.com)
- To cite this document: BenchChem. [Application Note: Rapid Microwave-Assisted Synthesis of Pyridine-3-ylmethyl Propanamide]. BenchChem, [2026]. [Online PDF]. Available at: [\[https://www.benchchem.com/product/b13204966/docs#application-note-rapid-microwave-assisted-synthesis-of-pyridine-3-ylmethyl-propanamide\]](https://www.benchchem.com/product/b13204966/docs#application-note-rapid-microwave-assisted-synthesis-of-pyridine-3-ylmethyl-propanamide)

Disclaimer & Data Validity:

The information provided in this document is for Research Use Only (RUO) and is strictly not intended for diagnostic or therapeutic procedures. While BenchChem strives to provide accurate protocols, we make no warranties, express or implied, regarding the fitness of this product for every specific experimental setup.

Technical Support: The protocols provided are for reference purposes. Unsure if this reagent suits your experiment?

Need Industrial/Bulk Grade? [Request Custom Synthesis Quote](#)

BenchChem

Our mission is to be the trusted global source of essential and advanced chemicals, empowering scientists and researchers to drive progress in science and industry.

Contact

Address: 3281 E Guasti Rd

Ontario, CA 91761, United States

Phone: (601) 213-4426

Email: info@benchchem.com

[Contact our Ph.D. Support Team for a compatibility check](#)