

# Structure Elucidation of 2-Chloro-5-(pyrrolidin-3-yl)pyridine

**Author:** BenchChem Technical Support Team. **Date:** May 2026

## Compound of Interest

Compound Name: 2-Chloro-5-(pyrrolidin-3-yl)pyridine

Cat. No.: B13202631

[Get Quote](#)

## Executive Summary: The Scaffold and Its Significance

**2-Chloro-5-(pyrrolidin-3-yl)pyridine** (CAS: 174789-86-7) represents a critical pharmacophore in the development of neuronal nicotinic acetylcholine receptor (nAChR) agonists.<sup>[1]</sup> Structurally, it serves as a precursor to high-affinity ligands such as Tebanicline (ABT-594) and Varenicline analogs.

The elucidation of this molecule presents two distinct challenges:

- **Regioisomerism:** Confirming the substitution pattern on the pyridine ring (2,5-substitution vs. 2,4- or 2,3-isomers).
- **Stereochemistry:** The pyrrolidine ring contains a chiral center at C3.<sup>[1]</sup> As synthesized, the material is often a racemate requiring chiral resolution and absolute configuration assignment.<sup>[1]</sup>

This guide details a self-validating analytical workflow to unambiguously determine the structure and stereochemistry of this scaffold.

## Analytical Strategy: The Elucidation Workflow

To ensure scientific rigor, we employ a "Triangulated Verification" approach. No single method is trusted in isolation; mass spectrometry provides the formula, NMR establishes connectivity, and Chiral HPLC/X-ray confirms stereochemistry.[1]

### Diagram 1: Elucidation Logic Flow

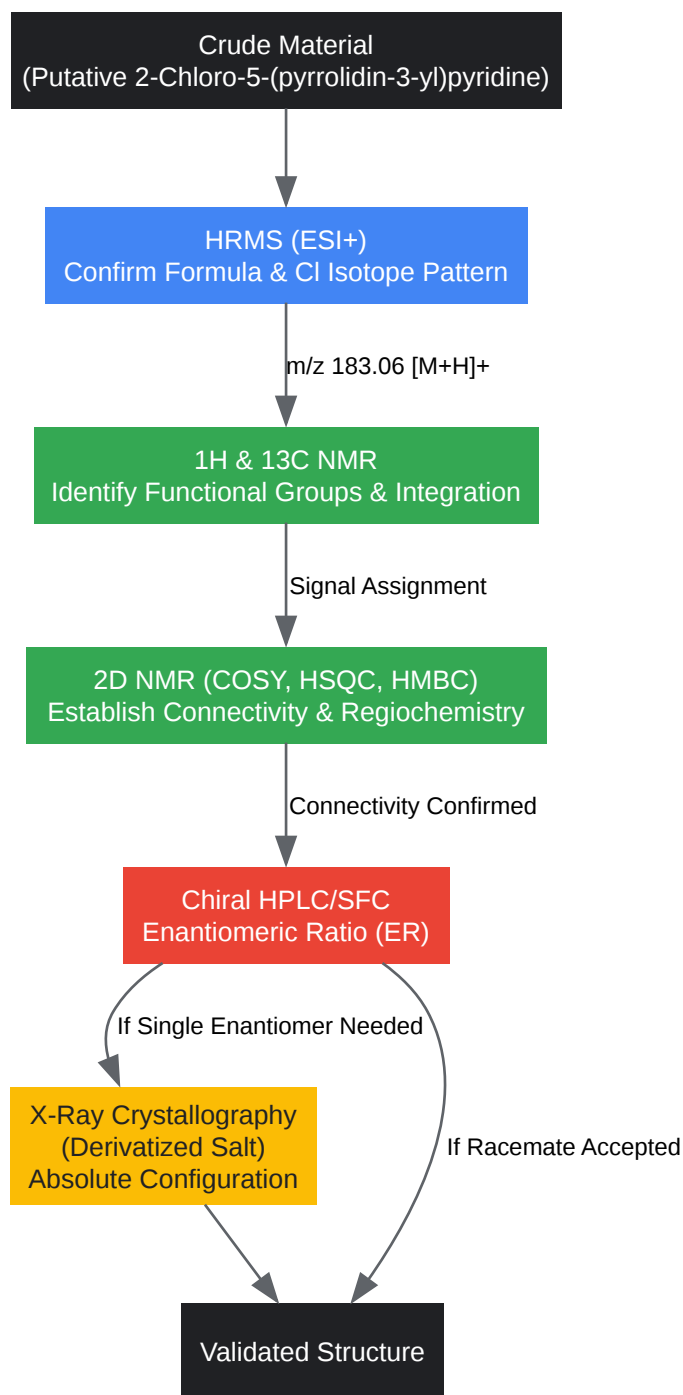

[Click to download full resolution via product page](#)

Caption: Step-by-step structural verification workflow ensuring rigorous exclusion of isomers.

## Molecular Formula & Mass Spectrometry

Objective: Confirm elemental composition and the presence of the chlorine atom.

- Method: High-Resolution Mass Spectrometry (HRMS), ESI+.[1]
- Expected Result:
  - Monoisotopic Mass: 182.06 Da (C  
H  
ClN  
).[1]
  - Observed Ion: [M+H]  
at m/z ~183.0690.[1]
  - Isotope Pattern: A distinct 3:1 intensity ratio between m/z 183.07 and 185.07 (Cl vs.  
Cl).[1]
- Validation Check: If the isotope pattern is 1:1, a bromine atom is present (incorrect starting material).[1] If no M+2 peak is observed, the chlorine has been lost (e.g., hydrodehalogenation side reaction).[1]

## NMR Spectroscopy: Connectivity & Regiochemistry

This is the most critical phase.[1] We must distinguish the 2,5-substituted isomer from potential 2,4- or 2,3-byproducts.

### **1H NMR Assignment (400 MHz, CDCl )**

Note: Chemical shifts are representative for the free base.<sup>[1]</sup> Salt formation (e.g., HCl) will downfield shift pyrrolidine protons significantly.<sup>[1]</sup>

Position	Type	(ppm)	Multiplicity	(Hz)	Structural Insight
Pyridine Ring					
Py-H6	Ar-CH	8.28	d	2.5	Diagnostic: Ortho to N, Meta to Cl. Small indicates meta-coupling to H4.
Py-H4	Ar-CH	7.65	dd	8.3, 2.5	Ortho to alkyl, Meta to Cl. Coupled to H3 (ortho) and H6 (meta).
Py-H3	Ar-CH	7.28	d	8.3	Ortho to Cl. Shielded relative to H6.
Pyrrolidine Ring					
Pyr-H3	CH	3.35	m	-	Chiral center. Benzylic-like position.
Pyr-H2	CH	3.15, 2.85	m	-	Diastereotopic protons adjacent to NH and chiral center.
Pyr-H5	CH	3.05	m	-	Adjacent to NH, distal to

					chiral center.
Pyr-H4	CH	2.25, 1.80	m	-	Bridge methylene.
NH	NH	2.10	br s	-	Exchangeable (disappears with D O shake).[1]

## Establishing Regiochemistry (2,5-Substitution)

The coupling pattern of the pyridine protons is the primary filter.[1]

- 2,5-Substitution: Requires a para-coupling (negligible) or meta-coupling ( Hz) between H4 and H6.[1] H3 and H4 should show a strong ortho-coupling ( Hz).[1]
- Rejection of 2,4-Isomer: A 2,4-substituted pyridine would show H6 (d, Hz) coupled to H5. The absence of a Hz coupling for the most deshielded proton (H6) rules out 2,4-substitution.[1]

## 2D NMR Connectivity (HMBC)

To irrefutably link the pyrrolidine ring to the C5 position of the pyridine, Heteronuclear Multiple Bond Correlation (HMBC) is required.[1]

## Diagram 2: HMBC Correlations

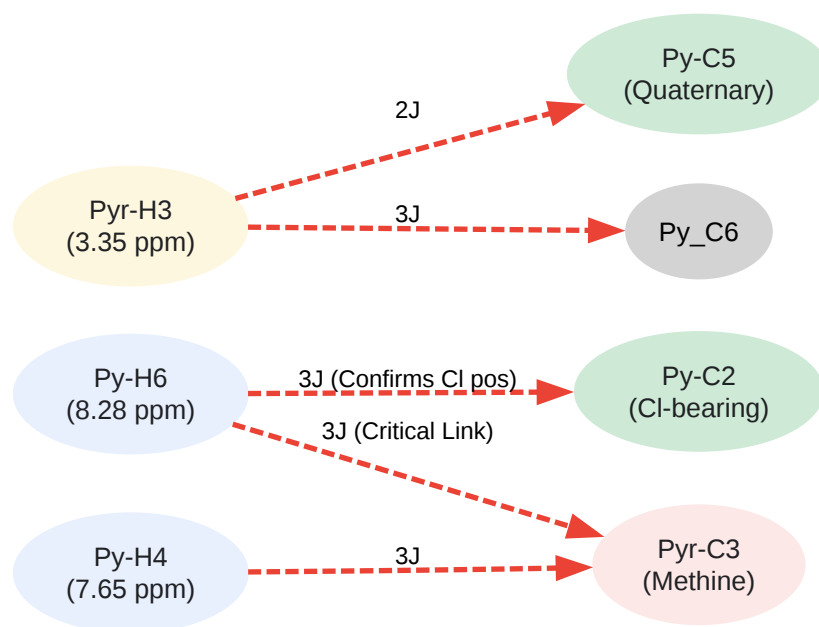

[Click to download full resolution via product page](#)

Caption: Key HMBC correlations linking the pyrrolidine methine (H3) to the pyridine core.

Interpretation:

- Py-H6 to Pyr-C3: This 3-bond correlation proves the pyrrolidine is attached at C5.
- Pyr-H3 to Py-C5 & Py-C6: Confirms the anchor point from the aliphatic side.

## Stereochemical Analysis

Since the molecule has one chiral center (C3 of pyrrolidine), it exists as a pair of enantiomers: (

) and (

).<sup>[1]</sup>

## Chiral HPLC Method Development

Standard reverse-phase C18 will not separate these enantiomers.

- Column: Immobilized Polysaccharide (e.g., Chiralpak IC or IA).<sup>[1]</sup>
- Mobile Phase: Hexane/IPA/Diethylamine (90:10:0.<sup>[1]</sup>1) or CO

/MeOH (SFC mode).[1]

- Detection: UV at 254 nm.[1]
- Protocol:
  - Inject racemate to establish retention times ( and ).[1]
  - Calculate Resolution ( ).[1] Target .[1][2]
  - Inject sample to determine Enantiomeric Excess ( ).[1][2]

## Absolute Configuration Assignment

To assign (

) vs (

) to peak 1 or peak 2:

- X-Ray Crystallography:
  - Synthesize a salt with a heavy atom (e.g., HBr salt) or a co-crystal with a chiral acid (e.g., Dibenzoyl-L-tartaric acid).[1]
  - Refine structure to determine the Flack parameter.[1] A value near 0 confirm absolute stereochemistry.[1]
- Optical Rotation:
  - Compare

with literature values for analogous 3-substituted pyrrolidines. Generally, (

)-isomers of 3-arylpyrrolidines exhibit negative rotation, but this must be experimentally verified via X-ray or circular dichroism (CD).[1]

## References

- Intermediate Synthesis: Process for the preparation of 2-chloro-5-chloromethyl-pyridine. US Patent 5329011A.[1] (Provides precursor data). [Link](#)
- Analogous Scaffolds: Holladay, M. W., et al. (1998).[1] Identification of Tebanicline (ABT-594), a novel, nonopioid analgesic.[1] Journal of Medicinal Chemistry. (Context for 3-substituted pyrrolidine pyridine ethers). [Link\[1\]](#)
- Chiral Separation: BenchChem. A Comparative Guide to the Chiral Separation of Pyrrolidine-3-Carboxylic Acid Enantiomers. (Methodology for pyrrolidine resolution). [Link\[1\]](#)
- NMR of Heterocycles: Elyashberg, M. (2015).[1] Identification and structure elucidation by NMR spectroscopy. TrAC Trends in Analytical Chemistry. [Link](#)

### Need Custom Synthesis?

BenchChem offers custom synthesis for rare earth carbides and specific isotopic labeling.

Email: [info@benchchem.com](mailto:info@benchchem.com) or [Request Quote Online](#).

## Sources

- [1. researchgate.net \[researchgate.net\]](https://www.researchgate.net)
- [2. pdf.benchchem.com \[pdf.benchchem.com\]](https://pdf.benchchem.com)
- To cite this document: BenchChem. [Structure Elucidation of 2-Chloro-5-(pyrrolidin-3-yl)pyridine]. BenchChem, [2026]. [Online PDF]. Available at: [\[https://www.benchchem.com/product/b13202631/docs#structure-elucidation-of-2-chloro-5-pyrrolidin-3-yl-pyridine\]](https://www.benchchem.com/product/b13202631/docs#structure-elucidation-of-2-chloro-5-pyrrolidin-3-yl-pyridine)

---

### Disclaimer & Data Validity:

The information provided in this document is for Research Use Only (RUO) and is strictly not intended for diagnostic or therapeutic procedures. While BenchChem strives to provide accurate protocols, we make no warranties, express or implied, regarding the fitness of this product for every specific experimental setup.

**Technical Support:** The protocols provided are for reference purposes. Unsure if this reagent suits your experiment?

**Need Industrial/Bulk Grade?** [Request Custom Synthesis Quote](#)

## BenchChem

Our mission is to be the trusted global source of essential and advanced chemicals, empowering scientists and researchers to drive progress in science and industry.

### Contact

Address: 3281 E Guasti Rd  
Ontario, CA 91761, United States  
Phone: (601) 213-4426  
Email: [info@benchchem.com](mailto:info@benchchem.com)

[Contact our Ph.D. Support Team for a compatibility check](#)