

Technical Guide: Substituted Indene Ligands for Metallocene Catalysts

Author: BenchChem Technical Support Team. **Date:** April 2026

Compound of Interest

Compound Name:	2-Ethyl-7-phenyl-1H-indene
CAS No.:	154380-63-9
Cat. No.:	B1319497

[Get Quote](#)

Precision Engineering of Polyolefin Microstructure

Executive Summary

This technical guide details the design, synthesis, and application of substituted indene ligands in Group 4 metallocene catalysis. While the primary application of these organometallic complexes is the polymerization of

-olefins (polypropylene, polyethylene), the ligand design principles share significant overlap with medicinal chemistry: steric locking, electronic tuning, and chirality transfer.

For researchers in drug development and materials science, this guide bridges the gap between small-molecule synthesis and macromolecular architecture. It focuses on the Spaleck-type systems (bridged, rigid) for isotactic control and Coates-Waymouth systems (unbridged, oscillating) for elastomeric properties.

Part 1: Ligand Design Principles

The unsubstituted bis(indenyl)zirconium dichloride is a poor catalyst for stereoregular polymerization due to ring rotation. To achieve high tacticity (stereoregularity) and molecular weight, the indene scaffold must be modified to restrict rotation and shape the active site.

The Symmetry-Stereocontrol Nexus

The symmetry of the ligand environment dictates the polymer microstructure. This is the "genetic code" of the catalyst.

- -Symmetric (Bridged): Forces the growing polymer chain to orient the same way for every insertion. Produces Isotactic Polypropylene (iPP).
 - Key Modification: Ansa-bridge (dimethylsilyl or ethylene) + 2,4-substitution.
- -Symmetric (Bridged): Mirrors the active site, causing alternating insertion orientations. Produces Syndiotactic Polypropylene (sPP).
 - Key Modification: Fluorenyl-Cp bridge.
- Oscillating

(Unbridged): The ligand rotates faster than the polymer chain grows, but slower than monomer insertion. Produces Stereoblock (Elastomeric) Polypropylene.[1]
 - Key Modification: 2-phenylindene (unbridged).[1][2]

The "Spaleck" Rules for Substitution

The evolution of the

system by W. Spaleck and colleagues established the standard for ligand substitution effects:

Position	Substituent	Effect	Mechanism
Bridge	>	Increased Rigidity	Opens the "bite angle," increasing activity and allowing larger monomers.
2-Position	Methyl / Ethyl	MW Increase	Sterically blocks the -hydride elimination pathway, preventing chain termination.
4-Position	Phenyl / Naphthyl	Tacticity Boost	Creates a "pocket" that forces the incoming propylene monomer into a specific enantioface.

Logic Flow: From Ligand to Polymer

The following diagram illustrates how ligand modifications translate to polymer properties.

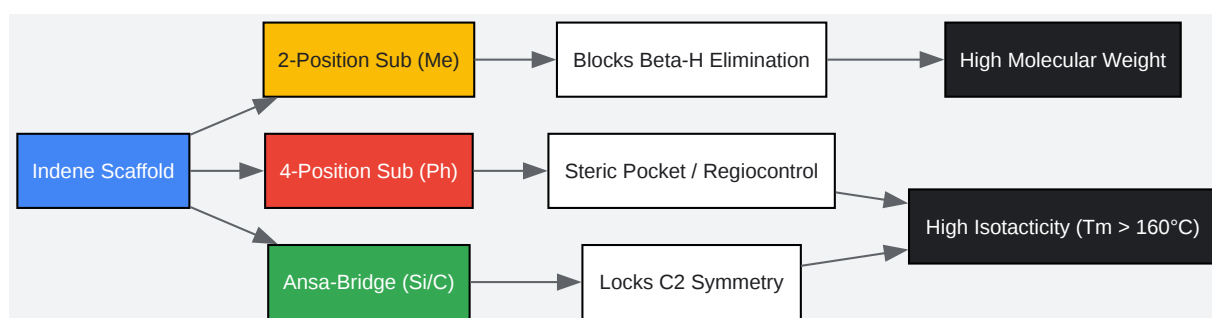

[Click to download full resolution via product page](#)

Caption: Causal relationship between specific indene substitutions and final polymer architecture.

Part 2: Synthetic Pathways

The synthesis of substituted indenenes typically follows a modular approach, allowing researchers to "plug and play" different steric groups.

The Indanone Route (General Protocol)

This is the most robust method for generating 2- and 4-substituted indenenes.

- Friedel-Crafts Acylation: Synthesis of the substituted indanone core.
- Grignard Addition: Introduction of the 2-position substituent (or 4-position via aryl-Grignard on a precursor).
- Dehydration: Acid-catalyzed elimination of water to form the double bond.

Workflow Visualization

The synthesis requires strict air-free techniques (Schlenk line or Glovebox) once the ligand is deprotonated.

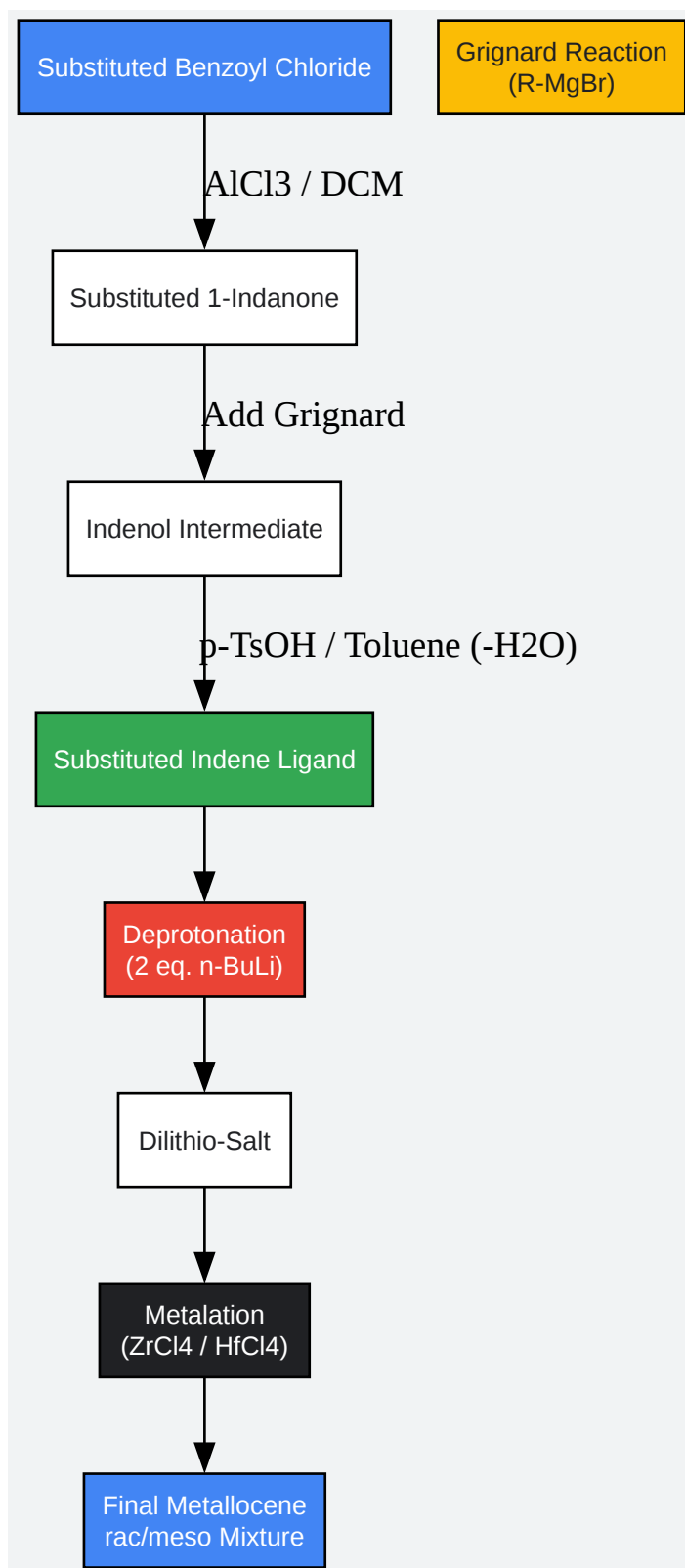

[Click to download full resolution via product page](#)

Caption: Step-by-step synthetic pathway from commercial precursors to active catalyst.

Part 3: Experimental Protocols

Safety Warning: Organolithium reagents are pyrophoric. Zirconium (IV) chloride is moisture-sensitive. All reactions must be performed under Argon or Nitrogen.

Protocol A: Synthesis of 2-methyl-4-phenylindene

This ligand is the precursor for high-performance iPP catalysts.

Reagents:

- 4-phenyl-1-indanone (Commercial or synthesized via Suzuki coupling)
- Methylmagnesium bromide (3.0 M in ether)
- p-Toluenesulfonic acid (p-TsOH)
- Toluene, Diethyl ether

Step-by-Step:

- Grignard Addition: Dissolve 4-phenyl-1-indanone (10 mmol) in anhydrous ether (50 mL). Cool to 0°C. Add MeMgBr (12 mmol) dropwise.
- Reflux: Allow to warm to RT, then reflux for 2 hours. The solution usually turns from yellow to orange/brown.
- Quench: Pour mixture into ice/dilute HCl. Extract with ether, wash with brine, dry over
. Evaporate solvent to yield the crude indenol.
- Dehydration: Dissolve crude indenol in Toluene (100 mL). Add catalytic p-TsOH (100 mg). Reflux with a Dean-Stark trap to remove water.
- Purification: Flash chromatography (Hexane/DCM) yields 2-methyl-4-phenylindene as a white/off-white solid.

Protocol B: Metallation (Formation of the Zirconocene)

Reagents:

- Ligand from Protocol A (2 eq.)
- n-Butyllithium (2.5 M in hexanes)[3]
- (Sublimed grade)
- THF (Anhydrous, distilled from Na/Benzophenone)

Step-by-Step:

- Deprotonation: Dissolve ligand (20 mmol) in THF (100 mL) in a Schlenk flask. Cool to -78°C (Dry ice/Acetone).
- Lithiation: Add n-BuLi (20 mmol) dropwise. The solution will turn deep red or yellow. Stir at -78°C for 1 hour, then warm to RT and stir for 4 hours.
- Salt Metathesis: In a glovebox or under counter-flow Argon, suspend (10 mmol) in THF (50 mL) at -78°C .
- Transfer: Cannulate the lithium salt solution into the slurry slowly.
- Reaction: Allow to warm to RT and stir overnight.
- Workup: Remove THF under vacuum. Extract residue with dry Dichloromethane (DCM). Filter through Celite to remove LiCl.
- Crystallization: Concentrate DCM and layer with dry Pentane. Store at -30°C to crystallize the rac isomer (often less soluble than meso).

Part 4: Performance Data

The following table summarizes the impact of ligand substitution on propylene polymerization performance (activated with Methylaluminoxane, MAO).

Catalyst System	Symmetry	Activity (kg/mol ·h)	Isotacticity ()	Melting Point ()	Molecular Weight ()
		Low	0% (Atactic)	N/A (Oil)	Low
		High	~85%	135°C	~50k
		Very High	~95%	145°C	~200k
		Ultra High	>98%	160°C	>700k
	Oscillating	Moderate	20-60% (Block)	130-150°C	Variable

Note: Data represents generalized values from Spaleck [2] and Coates [3] under standard conditions (Liquid propylene, 70°C).

References

- Brintzinger, H. H., et al. (1982). "Stereospecific Olefin Polymerization with Chiral Metallocene Catalysts." *Angewandte Chemie International Edition*, 21(2), 145-173.
- Spaleck, W., et al. (1994). "The Influence of Aromatic Substituents on the Polymerization Properties of Bridged Bis(indenyl)zirconocenes." *Organometallics*, 13(3), 954-963.
- Coates, G. W., & Waymouth, R. M. (1995).[4] "Oscillating Stereocontrol: A Strategy for the Synthesis of Thermoplastic Elastomeric Polypropylene." *Science*, 267(5195), 217-219. [1]
- Resconi, L., et al. (2000).[5] "Selectivity in Propene Polymerization with Metallocene Catalysts." *Chemical Reviews*, 100(4), 1253–1346.[5]
- Kaminsky, W. (1986). "Stereoselective Polymerization of Olefins with Homogeneous Chiral Ziegler-Natta Catalysts." *Angewandte Chemie*, 25, 509.

Need Custom Synthesis?

BenchChem offers custom synthesis for rare earth carbides and specific isotopic labeling.

Email: info@benchchem.com or [Request Quote Online](#).

Sources

- [1. Oscillating stereocontrol: a strategy for the synthesis of thermoplastic elastomeric polypropylene - PubMed \[pubmed.ncbi.nlm.nih.gov\]](#)
- [2. emich.edu \[emich.edu\]](#)
- [3. pdf.benchchem.com \[pdf.benchchem.com\]](#)
- [4. Coates, G.W. and Waymouth, R.M. \(1995\) Oscillating Stereocontrol A Strategy for the Synthesis of Thermoplastic Elastomeric Polypropylene. Science, 267, 217-219. - References - Scientific Research Publishing \[scirp.org\]](#)
- [5. Selectivity in propene polymerization with metallocene catalysts - PubMed \[pubmed.ncbi.nlm.nih.gov\]](#)
- [To cite this document: BenchChem. \[Technical Guide: Substituted Indene Ligands for Metallocene Catalysts\]. BenchChem, \[2026\]. \[Online PDF\]. Available at: \[https://www.benchchem.com/product/b1319497/docs#technical-guide-substituted-indene-ligands-for-metallocene-catalysts\]](#)

Disclaimer & Data Validity:

The information provided in this document is for Research Use Only (RUO) and is strictly not intended for diagnostic or therapeutic procedures. While BenchChem strives to provide accurate protocols, we make no warranties, express or implied, regarding the fitness of this product for every specific experimental setup.

Technical Support: The protocols provided are for reference purposes. Unsure if this reagent suits your experiment?

Need Industrial/Bulk Grade? [Request Custom Synthesis Quote](#)

BenchChem

Our mission is to be the trusted global source of essential and advanced chemicals, empowering scientists and researchers to drive progress in science and industry.

Contact

Address: 3281 E Guasti Rd

Ontario, CA 91761, United States

Phone: (601) 213-4426

Email: info@benchchem.com

[Contact our Ph.D. Support Team for a compatibility check](#)