

# Technical Monograph: 7-Chlorothieno[2,3-c]pyridine-4-carbothioamide

**Author:** BenchChem Technical Support Team. **Date:** May 2026

## Compound of Interest

**Compound Name:** 7-Chlorothieno[2,3-c]pyridine-4-carbothioamide

**Cat. No.:** B13186009

[Get Quote](#)

Scaffold Class: Thienopyridine | Functional Group: Thioamide | Application: Kinase Inhibition & Heterocyclic Synthesis

## Executive Summary

The **7-chlorothieno[2,3-c]pyridine-4-carbothioamide** is a bifunctional heteroaromatic scaffold. It combines the electron-deficient thieno[2,3-c]pyridine core with two distinct reactive handles: an electrophilic chlorine at position C7 and a nucleophilic/electrophilic thioamide moiety at position C4.

This molecule is not merely a static intermediate; it is a "linchpin" scaffold. The C7-chloro group is activated for palladium-catalyzed cross-couplings (Suzuki-Miyaura, Buchwald-Hartwig), while the C4-thioamide serves as a critical precursor for Hantzsch thiazole synthesis, allowing the rapid construction of tricyclic systems (e.g., thiazolo[5,4-c]thieno[2,3-e]pyridines) often found in potent PI3K, mTOR, and c-Src inhibitors.

## Chemical Identity & Structural Analysis[1][2][3][4]

### Core Properties

Property	Data
Chemical Name	7-Chlorothieno[2,3-c]pyridine-4-carbothioamide
Molecular Formula	C <sub>8</sub> H <sub>5</sub> ClN <sub>2</sub> S <sub>2</sub>
Molecular Weight	228.72 g/mol
Core Scaffold	Thieno[2,3-c]pyridine
Key Substituents	7-Chloro (Halogen), 4-Carbothioamide (Thioamide)
Precursor CAS	28948-58-5 (7-chlorothieno[2,3-c]pyridine parent)
Solubility	DMSO, DMF (High); Ethanol (Moderate); Water (Low)

## Structural Numbering & Electronic Profile

Understanding the IUPAC numbering is critical for regio-control during functionalization.

- **Position 7 (Alpha to Nitrogen):** The carbon adjacent to the pyridine nitrogen is highly electron-deficient. The chlorine atom here is activated for nucleophilic aromatic substitution (S<sub>N</sub>Ar) or oxidative addition by transition metals.
- **Position 4 (Gamma to Nitrogen):** Located on the pyridine ring adjacent to the thiophene fusion. The thioamide group here acts as a 1,3-binucleophile (S and N) for heterocyclization.

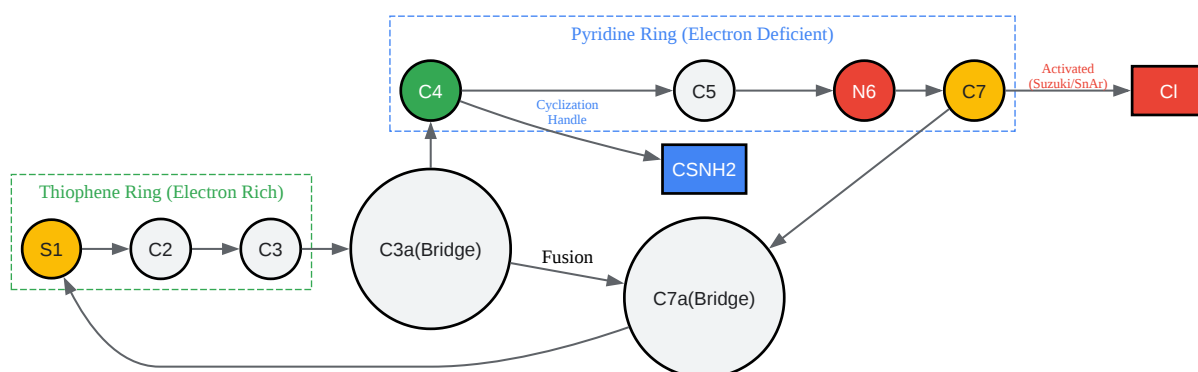

[Click to download full resolution via product page](#)

Figure 1: Structural connectivity and reactivity map of the 7-chlorothieno[2,3-c]pyridine scaffold.

## Synthetic Methodology

The synthesis of the 4-carbothioamide derivative typically proceeds from the corresponding nitrile or carboxamide. The most robust protocol utilizes Lawesson's Reagent to convert the carbonyl/cyano group to a thiocarbonyl.

Prerequisite: Start with 7-chlorothieno[2,3-c]pyridine-4-carboxamide (CAS 2059954-95-7) or the 4-cyano analog.

## Protocol: Thionation via Lawesson's Reagent

This protocol describes the conversion of the amide to the thioamide.<sup>[1][2][3]</sup> This method is preferred over P<sub>4</sub>S<sub>10</sub> due to milder conditions and cleaner workup.

### Reagents & Materials:

- Substrate: 7-Chlorothieno[2,3-c]pyridine-4-carboxamide (1.0 eq)

- Reagent: Lawesson's Reagent (0.6 eq)
- Solvent: Anhydrous Toluene (0.1 M concentration)
- Atmosphere: Nitrogen or Argon

## Step-by-Step Procedure:

- Setup: Flame-dry a round-bottom flask equipped with a magnetic stir bar and a reflux condenser. Purge with nitrogen.
- Dissolution: Charge the flask with the carboxamide substrate and anhydrous toluene. Stir until a suspension or solution is formed.
- Addition: Add Lawesson's Reagent in a single portion. Note: Lawesson's reagent is moisture-sensitive; handle quickly.
- Reaction: Heat the mixture to reflux (110°C) for 2–4 hours.
  - Monitoring: Monitor via TLC (Mobile phase: 50% EtOAc/Hexanes). The product will be less polar (higher R<sub>f</sub>) than the starting amide.
- Workup (Critical Step):
  - Cool the reaction to room temperature.
  - Option A (Filtration): If the product precipitates upon cooling, filter the solid, wash with cold toluene, and dry.
  - Option B (Chromatography): If soluble, concentrate the toluene in vacuo. Adsorb the residue onto silica gel.
- Purification: Flash column chromatography using a gradient of 0–40% EtOAc in Hexanes. The thioamide is typically a bright yellow solid.

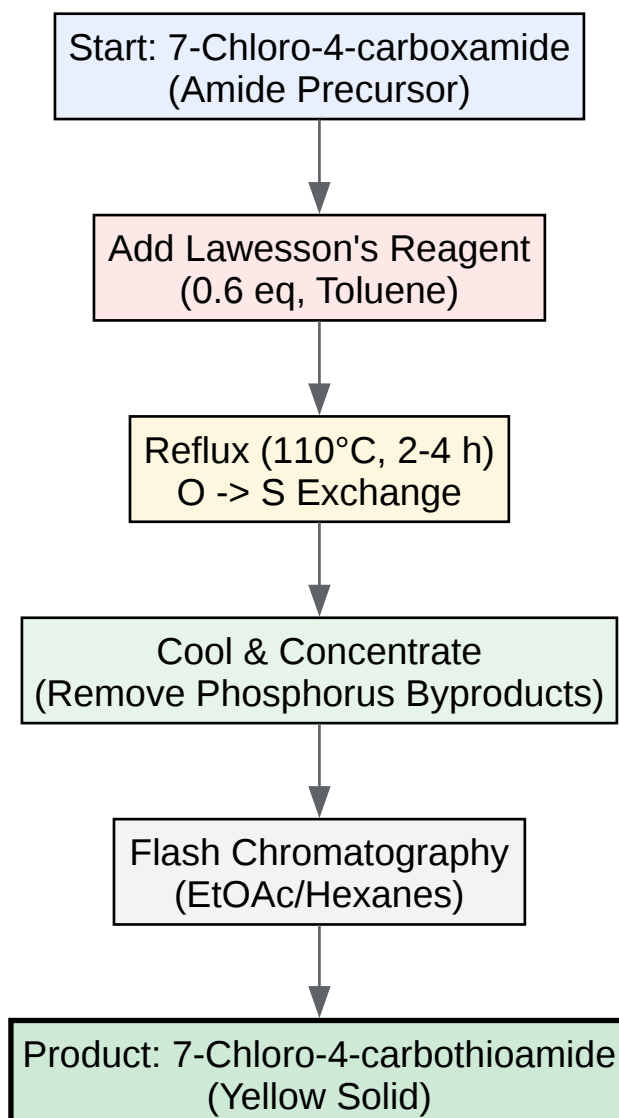

[Click to download full resolution via product page](#)

Figure 2: Synthetic workflow for the thionation of the carboxamide precursor.

## Reactivity & Application Logic

### The Hantzsch Cyclization (Thiazole Formation)

The primary utility of the 4-carbothioamide is its ability to react with

-haloketones to form thiazoles. This creates a tricyclic thiazolo[4',5':4,5]thieno[2,3-c]pyridine system.

- Mechanism: The sulfur atom of the thioamide attacks the

-carbon of the haloketone (S\_N2), followed by cyclodehydration involving the amide nitrogen.

- Why it matters: This fusion locks the conformation of the molecule, often improving binding affinity in kinase ATP pockets (e.g., c-Met, VEGFR).

## C7-Chloro Diversification

The C7-chloro group should ideally be derivatized after thioamide manipulation to avoid catalyst poisoning by sulfur.

- Suzuki-Miyaura: Coupling with aryl-boronic acids introduces hydrophobic bulk, essential for occupying the hydrophobic back-pocket of kinase enzymes.
- Buchwald-Hartwig: Amination at C7 can introduce solubility-enhancing groups (e.g., morpholine, piperazine).

## Safety & Handling (E-E-A-T)

- H<sub>2</sub>S Evolution: Thioamides can hydrolyze or decompose to release Hydrogen Sulfide (H<sub>2</sub>S) under acidic conditions. H<sub>2</sub>S is a potent neurotoxin. Always open reaction vessels in a well-ventilated fume hood.
- Lawesson's Reagent: Releases foul-smelling phosphorus byproducts. Quench glassware in a bleach bath to oxidize sulfur residues before washing.
- Skin Contact: Thienopyridines can be potent skin sensitizers. Double-gloving (Nitrile) is recommended.

## References

- Thieno[2,3-c]pyridine Scaffold Properties
  - PubChem Compound Summary for CID 9224, Thieno[2,3-c]pyridine. National Center for Biotechnology Information (2025). [Link](#)
- Lawesson's Reagent Methodology

- Ozturk, T., et al. "Use of Lawesson's Reagent in Organic Syntheses." *Chemical Reviews*, 2007. [Link](#)
- Synthesis of Thienopyridine Derivatives
  - Litvinov, V. P. "Thienopyridines: Synthesis, Properties, and Biological Activity." [4][5][6][7] *Russian Chemical Reviews*, 2004.
- Precursor Availability (7-chlorothieno[2,3-c]pyridine)
  - Cayman Chemical Product Data, CAS 28948-58-5.[8] [Link](#)

### Need Custom Synthesis?

BenchChem offers custom synthesis for rare earth carbides and specific isotopic labeling.

Email: [info@benchchem.com](mailto:info@benchchem.com) or [Request Quote Online](#).

## Sources

- [1. mdpi.com \[mdpi.com\]](#)
- [2. Thioamide synthesis by thionation \[organic-chemistry.org\]](#)
- [3. Lawesson's Reagent \[organic-chemistry.org\]](#)
- [4. researchgate.net \[researchgate.net\]](#)
- [5. 7-Chlorothieno\[2,3-c\]pyridine | C7H4ClNS | CID 15914129 - PubChem \[pubchem.ncbi.nlm.nih.gov\]](#)
- [6. mdpi.com \[mdpi.com\]](#)
- [7. Structure–Activity Relationship of N-Phenylthieno\[2,3-b\]pyridine-2-carboxamide Derivatives Designed as Forkhead Box M1 Inhibitors: The Effect of Electron-Withdrawing and Donating Substituents on the Phenyl Ring \[mdpi.com\]](#)
- [8. caymanchem.com \[caymanchem.com\]](#)
- To cite this document: BenchChem. [Technical Monograph: 7-Chlorothieno[2,3-c]pyridine-4-carbothioamide]. BenchChem, [2026]. [Online PDF]. Available at: [\[https://www.benchchem.com/product/b13186009/docs#technical-monograph-7-chlorothieno-2-3-c-pyridine-4-carbothioamide\]](https://www.benchchem.com/product/b13186009/docs#technical-monograph-7-chlorothieno-2-3-c-pyridine-4-carbothioamide)

**Disclaimer & Data Validity:**

The information provided in this document is for Research Use Only (RUO) and is strictly not intended for diagnostic or therapeutic procedures. While BenchChem strives to provide accurate protocols, we make no warranties, express or implied, regarding the fitness of this product for every specific experimental setup.

**Technical Support:** The protocols provided are for reference purposes. Unsure if this reagent suits your experiment?

**Need Industrial/Bulk Grade?** [Request Custom Synthesis Quote](#)

## BenchChem

Our mission is to be the trusted global source of essential and advanced chemicals, empowering scientists and researchers to drive progress in science and industry.

### Contact

Address: 3281 E Guasti Rd  
Ontario, CA 91761, United States  
Phone: (601) 213-4426  
Email: [info@benchchem.com](mailto:info@benchchem.com)

[Contact our Ph.D. Support Team for a compatibility check](#)