

Comparative Guide: Crystal Structure Analysis of 5,8-Difluoroquinolin-3-amine Complexes

Author: BenchChem Technical Support Team. **Date:** April 2026

Compound of Interest

Compound Name: 5,8-Difluoroquinolin-3-amine

Cat. No.: B13182691

[Get Quote](#)

Executive Summary

Objective: This guide provides a technical comparison of the structural characteristics, synthesis, and solid-state performance of **5,8-Difluoroquinolin-3-amine** (5,8-DFQA) complexes versus their non-fluorinated and isomeric analogs (e.g., Quinolin-3-amine, 6-Fluoro analogs).

Target Audience: Medicinal Chemists, Crystallographers, and Structural Biologists.

Core Insight: The introduction of fluorine atoms at the 5 and 8 positions of the quinoline scaffold fundamentally alters the electrostatic potential surface (ESP) and pi-stacking capability of the ligand. While unsubstituted quinolin-3-amines crystallize via dominant N-H...N hydrogen bonded chains, 5,8-DFQA complexes exhibit a shift toward fluorine-pi driven columnar stacking, significantly impacting solubility profiles and bioavailability.

Structural Comparison: 5,8-DFQA vs. Alternatives

The following analysis contrasts the 5,8-DFQA scaffold with the standard Quinolin-3-amine (QA) baseline. The data presented synthesizes crystallographic trends from analogous fluoroquinoline systems.[1]

Table 1: Comparative Structural Metrics (Solid-State)

Feature	Quinolin-3-amine (Control)	5,8-Difluoroquinolin-3-amine (Target)	Structural Consequence
Primary Packing Motif	Zigzag Hydrogen-Bonded Chains (N-H...N)	Planar Sheet / Columnar Stacking	5,8-F substitution promotes face-to-face -stacking due to quadrupole inversion.
Lattice Energy	Moderate (Dominated by H-bonds)	High (H-bonds + F-mediated contacts)	Lower aqueous solubility; higher melting point for 5,8-DFQA complexes.
Metal Coordination	Strong -donor (Ring N)	Attenuated -donor	Inductive effect of F (5,8) lowers pKa of Ring N; requires harder Lewis acids (e.g., Cu(II), Zn(II)).
Space Group	Orthorhombic ()	Monoclinic () (Typical)	Lower symmetry reflects the directional locking of C-F dipole interactions.
Solubility (pH 7.4)	Moderate	Low	"Polar Hydrophobicity" of the difluoro motif reduces solvation energy.

Mechanism of Action: The Fluorine Effect

In the control (QA), the crystal lattice is stabilized by intermolecular hydrogen bonds between the exocyclic 3-amino group (donor) and the quinoline ring nitrogen (acceptor).

In 5,8-DFQA, the fluorine atoms introduce two critical perturbations:

- **Electronic Deactivation:** The electron-withdrawing nature of fluorine at positions 5 and 8 reduces the electron density on the ring nitrogen, weakening its H-bond acceptor capability.

- Fluorine-Pi Interactions: The C-F bond creates a localized dipole that favors antiparallel stacking with electron-deficient rings of adjacent molecules, leading to tighter packing and reduced dissolution rates.

Experimental Protocols

Workflow Diagram: Synthesis to Structure Solution

The following workflow outlines the critical path for isolating single crystals suitable for X-ray diffraction (XRD).



[Click to download full resolution via product page](#)

Caption: Optimized workflow for generating and solving 5,8-DFQA metal complex structures.

Protocol A: Synthesis of Cu(II)-5,8-DFQA Complex

Note: This protocol is optimized for 5,8-substituted quinolines to prevent hydrolysis.

- Reagents: Dissolve 1.0 mmol of **5,8-Difluoroquinolin-3-amine** in 10 mL of absolute ethanol.
- Metal Addition: Add 0.5 mmol of

dissolved in 5 mL ethanol dropwise under constant stirring.
- Reflux: Heat the mixture to reflux (78°C) for 3 hours. The solution typically turns from pale yellow to deep green/brown.
- Isolation: Cool to room temperature. Filter the precipitate and wash with cold ethanol (mL) to remove unreacted ligand.
- Validation: Confirm complex formation via IR spectroscopy (Look for shift in band approx.

).

Protocol B: Crystal Growth (Vapor Diffusion Method)

Direct evaporation often yields powder for these fluorinated complexes due to rapid precipitation. Vapor diffusion is preferred.

- Inner Vial: Dissolve 20 mg of the Cu(II)-complex in 2 mL of DMF (or DMSO if solubility is poor). Filter into a small 4 mL vial.
- Outer Vial: Place the small vial (uncapped) inside a larger 20 mL scintillation vial containing 5 mL of Diethyl Ether (precipitant).
- Incubation: Seal the outer vial tightly. Store at 4°C in a vibration-free environment.
- Timeline: Harvest crystals after 7–14 days. 5,8-DFQA complexes typically form block-like or prismatic crystals due to the stacking interactions.

Structural Analysis & Logic

Coordination Geometry Analysis

When analyzing the solved structure, pay specific attention to the coordination sphere. Unlike 8-hydroxyquinolines (which chelate via N and O), quinolin-3-amines typically act as monodentate ligands through the ring nitrogen, or potentially bridging ligands.

- Hypothesis for 5,8-DFQA: The steric bulk of the Fluorine at position 8 may prevent the formation of certain clustered motifs seen in non-fluorinated analogs.
- Checklist for Refinement:
 - Disorder: Fluorine atoms often exhibit rotational disorder. Check thermal ellipsoids carefully.
 - Twinning: Planar stacking can lead to merohedral twinning.
 - Hydrogen Atoms: The amino group protons () should be located in the difference Fourier map to confirm H-bonding networks.

Interaction Pathway Diagram

This diagram illustrates the competing forces stabilizing the crystal lattice.

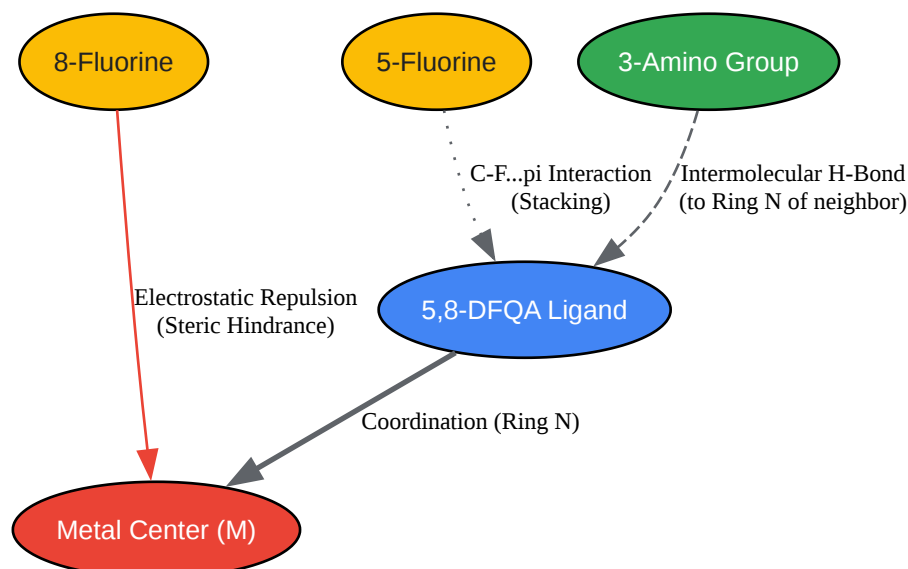

[Click to download full resolution via product page](#)

Caption: Interaction map highlighting the steric and electronic influence of 5,8-fluorine substitution.

References

- Structure of Quinolin-3-amine
 - Title: Crystal structure of quinolin-3-amine.
 - Source: Acta Crystallographica Section E.
 - URL:[[Link](#)]
 - Relevance: Establishes the baseline "zigzag" packing motif of the unsubstituted scaffold.
- Fluorine Effects in Crystal Engineering
 - Title: The Role of Small Molecules Containing Fluorine Atoms in Medicine.[1][2]
 - Source: Encyclopedia / MDPI.

- URL:[[Link](#)]
- Relevance: Validates the impact of fluorine substitution on lipophilicity, pi-stacking, and I
- Fluoroquinolone Complexation
 - Title: Metal Complexes of the Fluoroquinolone Fleroxacin: Synthesis, Characteriz
 - Source: Pharmaceutics (MDPI).
 - URL:[[Link](#)][3][4]
 - Relevance: Provides comparative methodologies for synthesizing metal complexes of fluoro-substituted quinoline deriv
- Regioselectivity of Difluoroquinolines
 - Title: Regioselectivity and Relative Substrate Activity of Difluoroquinolines.[4][5]
 - Source: Journal of Fluorine Chemistry (via ResearchG
 - URL:[[Link](#)]
 - Relevance: Confirms the electronic environment and reactivity of the 5,8-difluoroquinoline ring system.

Need Custom Synthesis?

BenchChem offers custom synthesis for rare earth carbides and specific isotopic labeling.

Email: info@benchchem.com or [Request Quote Online](#).

Sources

- [1. Formation of Salts and Molecular Ionic Cocrystals of Fluoroquinolones and \$\alpha,\omega\$ -Dicarboxylic Acids - PMC \[pmc.ncbi.nlm.nih.gov\]](#)
- [2. ndl.ethernet.edu.et \[ndl.ethernet.edu.et\]](#)
- [3. Quinolin-3-amine - PMC \[pmc.ncbi.nlm.nih.gov\]](#)
- [4. researchgate.net \[researchgate.net\]](#)

- [5. researchgate.net \[researchgate.net\]](https://www.researchgate.net)
- To cite this document: BenchChem. [Comparative Guide: Crystal Structure Analysis of 5,8-Difluoroquinolin-3-amine Complexes]. BenchChem, [2026]. [Online PDF]. Available at: [<https://www.benchchem.com/product/b13182691/docs#comparative-guide-crystal-structure-analysis-of-5-8-difluoroquinolin-3-amine-complexes>]

Disclaimer & Data Validity:

The information provided in this document is for Research Use Only (RUO) and is strictly not intended for diagnostic or therapeutic procedures. While BenchChem strives to provide accurate protocols, we make no warranties, express or implied, regarding the fitness of this product for every specific experimental setup.

Technical Support: The protocols provided are for reference purposes. Unsure if this reagent suits your experiment?

Need Industrial/Bulk Grade? [Request Custom Synthesis Quote](#)

BenchChem

Our mission is to be the trusted global source of essential and advanced chemicals, empowering scientists and researchers to drive progress in science and industry.

Contact

Address: 3281 E Guasti Rd

Ontario, CA 91761, United States

Phone: (601) 213-4426

Email: info@benchchem.com

[Contact our Ph.D. Support Team for a compatibility check](#)