

Technical Support Center: Troubleshooting Sulfinate Radical Reactions

Author: BenchChem Technical Support Team. **Date:** April 2026

Compound of Interest

Compound Name: Sodium (4-cyanophenyl)methanesulfinate
Cat. No.: B13181980

[Get Quote](#)

Welcome to the Application Scientist Support Hub

As researchers and drug development professionals, you know that sulfinate radical chemistry—whether utilizing Langlois reagent (sodium trifluoromethanesulfinate), Baran reagents (zinc sulfinate), or photoredox-catalyzed desulfinate couplings—is a transformative tool for late-stage C–H functionalization and cross-coupling. However, low conversion rates, poor radical generation, and competing side reactions can frequently halt experimental progress.

As a Senior Application Scientist, I have designed this guide to move beyond basic troubleshooting. Here, we will dissect the mechanistic causality behind reaction failures and implement self-validating protocols to ensure your radical chemistry is robust, reproducible, and scalable.

Diagnostic Workflow for Low Conversion

Before adjusting equivalents or changing catalysts, use the following logical workflow to isolate the root cause of your stalled reaction.

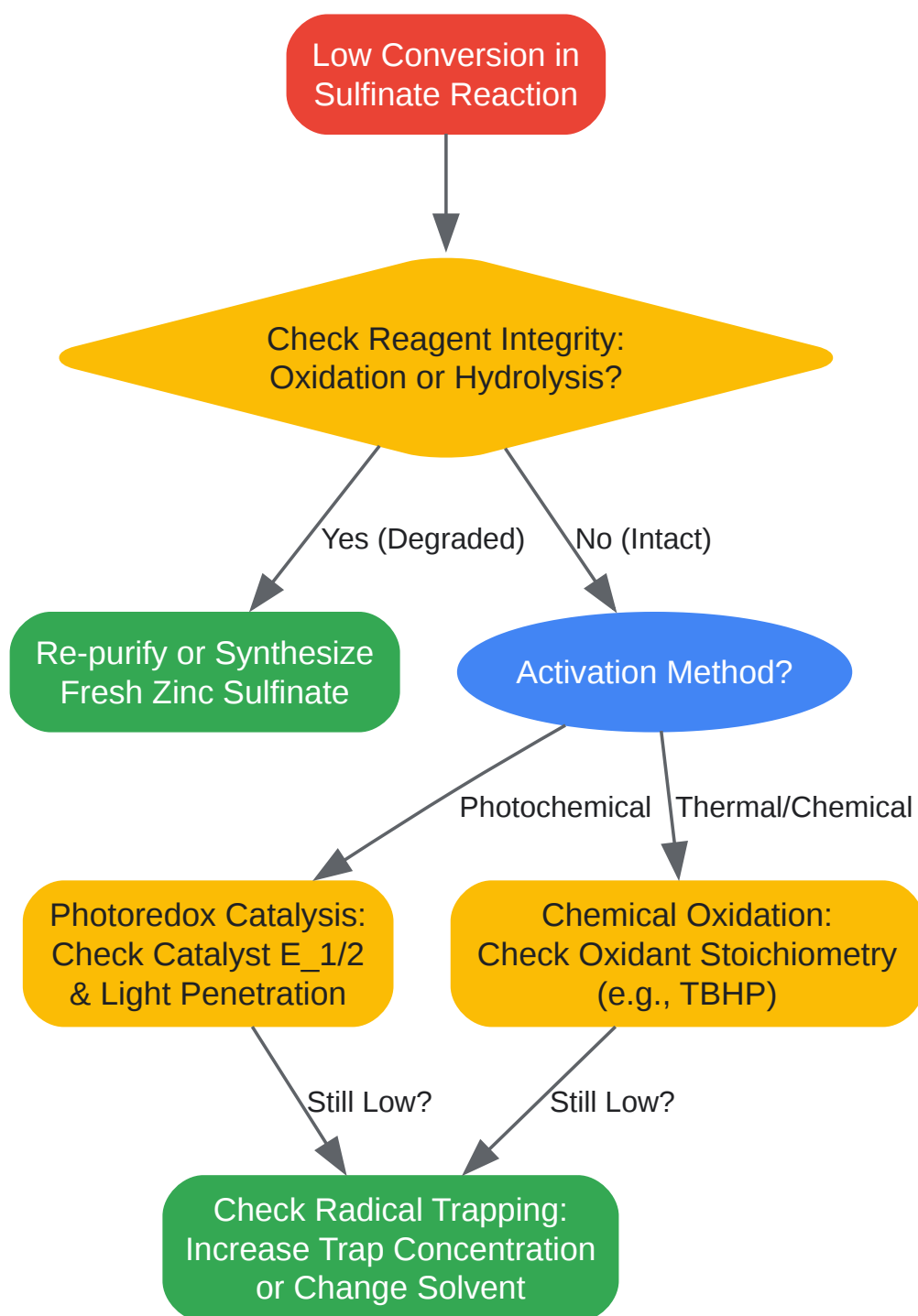

[Click to download full resolution via product page](#)

Diagnostic workflow for troubleshooting low conversion in sulfinate radical reactions.

Core Troubleshooting Guides (Q&A)

Q1: My Baran reagent reactions are stalling at <20% conversion despite using excess reagent. What is the mechanistic cause? A1: Reagent Degradation and Oxidant Quenching. Sulfinate salts are highly prone to oxidation to sulfonates or hydrolysis, especially in the presence of adventitious moisture. As detailed in , zinc bis(alkanesulfinate) salts can incorporate water and zinc chloride during synthesis, which drastically dampens their reactivity[1]. If your reagent is degraded, the necessary single-electron transfer (SET) to generate the sulfonyl radical (R-SO₂·) will fail. Furthermore, degraded sulfonates can non-productively consume chemical oxidants like tert-butyl hydroperoxide (TBHP). Actionable Fix: Perform a simple purification (see Protocol A below) to remove ZnCl₂ and water. Validate reagent integrity via LCMS; a successful difluoromethylation should yield a clean M+50 peak[2].

Q2: In my photoredox desulfinate coupling, the sulfinate salt is not generating the alkyl radical. How do I fix this? A2: Redox Potential Mismatch or Inefficient Excitation. The rate-determining step in photoredox sulfinate activation is the SET from the sulfinate anion to the excited state of the photocatalyst. Alkyl sulfinate salts typically possess low oxidative half-potentials ($E_{1/2ox} < 1.00$ V vs Ag/AgCl)[3]. If your photocatalyst's excited-state reduction potential is not sufficiently positive, the SET will not occur. Additionally, high substrate concentrations can cause the inner filter effect, preventing light penetration. Actionable Fix: Switch to a more strongly oxidizing photocatalyst such as Ir[dF(CF₃)ppy]₂(dtbbpy)PF₆ ($E_{1/2red}[*Ir^{III}/Ir^{II}] = +1.21$ V vs SCE)[4]. Validate excitation using a Stern-Volmer quenching study to confirm the sulfinate is actively quenching the catalyst's excited state.

Q3: I am generating the sulfonyl radical successfully, but I observe massive amounts of dimerization (e.g., disulfone formation) rather than cross-coupling. Why? A3: Competing Pathways and Radical Lifetime. Sulfonyl radicals face a kinetic bifurcation: they can either extrude SO₂ to form alkyl radicals (desulfinate pathway) or add directly to electron-deficient olefins (sulfonylative pathway)[5]. If the desired trapping is slow, dimerization or hydrogen atom abstraction (HAT) from the solvent dominates. Actionable Fix: If aiming for sulfonylation, increase the concentration of the radical trap (e.g., acrylate) to outcompete dimerization[6]. If aiming for desulfination, increase the reaction temperature slightly to overcome the activation barrier for SO₂ extrusion, or switch to a less H-atom donating solvent (e.g., from THF to MeCN).

Quantitative Data: Sulfinate Reagent Comparison

To ensure optimal reaction design, compare the physicochemical properties of your chosen radical precursor against the table below.

| Reagent Type | Example Structure | Typical Oxidation Potential (E _{1/2ox}) | Optimal Solvents | Common Pitfalls |
|------------------------------------|-------------------------------------|---|------------------------------|---|
| Sodium Sulfonates (Langlois) | CF ₃ SO ₂ Na | ~ +1.05 V vs SCE | DMSO, MeCN, H ₂ O | Highly hygroscopic; prone to background oxidation to sulfonate. |
| Zinc Bis(alkanesulfonates) (Baran) | (RSO ₂) ₂ Zn | ~ +0.70 to +0.90 V vs SCE | DCM/ H ₂ O , DMSO | Incorporation of ZnCl ₂ and water during crude synthesis[7]. |
| Alkyl Sodium Sulfonates | RSO ₂ Na | < +1.00 V vs Ag/AgCl[3] | MeCN, DMF | Slow SO ₂ extrusion leading to premature dimerization[5]. |

Self-Validating Experimental Protocols

Protocol A: Preparation and Purification of Zinc Sulfinate Reagents

Mechanistic Goal: Remove adventitious water and zinc chloride to restore the effective molarity of the radical precursor[1].

- Suspension: Suspend the crude zinc bis(alkanesulfinate) salt in a minimal volume of deionized water (approx. 2 mL per gram of crude material).
- Filtration: Filter the suspension through a pad of Celite to remove unreacted zinc dust and insoluble zinc oxide byproducts.
- Lyophilization (Critical Step): Flash-freeze the filtrate and lyophilize to dryness. Causality: Rotary evaporation applies thermal stress that can prematurely cleave the sensitive S–Zn

bond; lyophilization removes water safely.

- Trituration: Triturate the resulting fluffy white solid with cold dichloromethane (DCM) to remove organic impurities, then filter and dry under high vacuum.
- Validation: Perform a simple ^1H NMR in D_2O or $\text{DMSO}-d_6$. The absence of broad water peaks and sharp integration of the alkyl/aryl protons confirms reagent integrity.

Protocol B: Standardized Photoredox Generation of Sulfonyl Radicals

Mechanistic Goal: Ensure efficient SET and trap the sulfonyl radical before dimerization occurs, as established by Ley and colleagues in [5].

- Reaction Assembly: In an oven-dried vial, combine the sulfonyl tetrazole or sulfinate precursor (1.0 equiv), the electron-deficient olefin (e.g., ethyl acrylate, 5.0 equiv), and the photocatalyst ($\text{Ir}[\text{dF}(\text{CF}_3)\text{ppy}]_2(\text{dtbpy})\text{PF}_6$, 2 mol%) in anhydrous MeCN.
- Additive Inclusion: Add DMAP (1.0 equiv) and $\text{Cu}(\text{OAc})_2$ (20 mol%). Causality: DMAP acts as an essential electron-transfer mediator to facilitate catalyst turnover[8].
- Degassing (Critical Step): Degas the mixture via three freeze-pump-thaw cycles. Causality: Molecular oxygen is a potent triplet quencher that will rapidly deactivate the $\text{Ir}(\text{III})^*$ excited state.
- Irradiation: Irradiate with a 14 W 420 nm blue LED for 16 hours at ambient temperature.
- Validation: Spike a small aliquot with TEMPO. Complete inhibition of the product formation confirms the reaction is proceeding via the intended open-shell radical pathway[9].

Mechanistic Pathway: Photoredox Sulfonylation

Understanding the catalytic cycle is essential for troubleshooting. The diagram below maps the electron flow and radical trapping sequence.

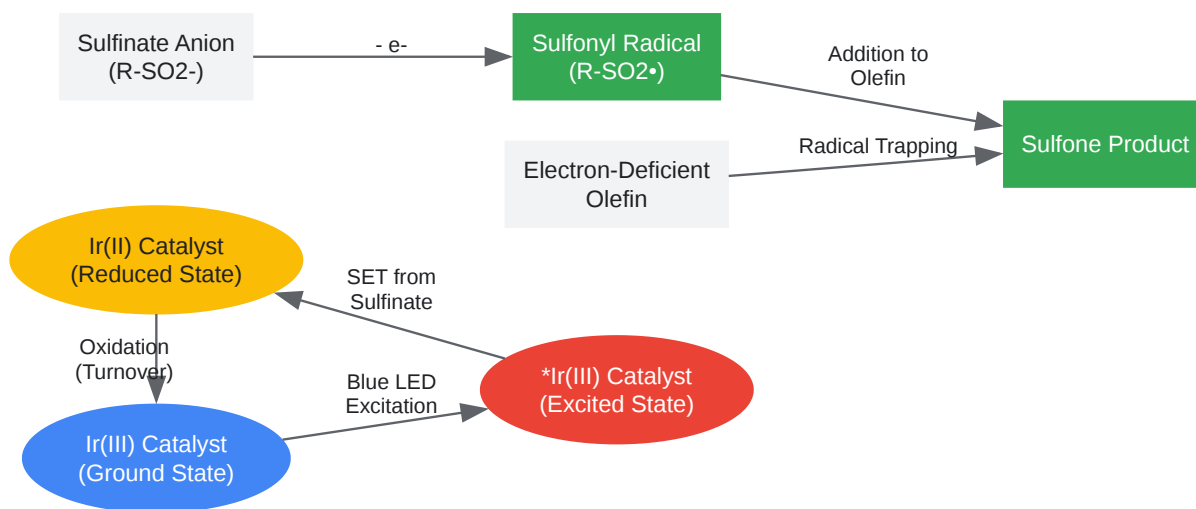

[Click to download full resolution via product page](#)

Photoredox catalytic cycle for sulfonyl radical generation and olefin trapping.

Frequently Asked Questions (FAQs)

Q: Can I run these photoredox sulfinate reactions in continuous flow? A: Yes. In fact, scaling up photoredox reactions in batch often leads to low conversion due to the Beer-Lambert law (poor light penetration). Continuous-flow microreactors significantly increase the surface-area-to-volume ratio, ensuring uniform irradiation and reducing overoxidation[10].

Q: Why does my desulfonative cross-coupling fail when I use primary alkyl sulfonates? A: Primary alkyl radicals are highly unstable and their generation via SO₂ extrusion is thermodynamically uphill compared to secondary or tertiary radicals. To force the extrusion, you may need to utilize dual metallaphotoredox catalysis (e.g., Ru/Ni systems) where the transition metal stabilizes the intermediate[3].

Q: Is it absolutely necessary to degas the solvent for Baran reagent chemistry? A: If you are using chemical oxidants (like TBHP) in open air, degassing is less critical. However, if you are

utilizing photoredox generation, degassing is non-negotiable. Oxygen will quench the excited photocatalyst and can also intercept the generated carbon-centered radicals to form peroxides.

References

- Photoredox Generation of Sulfonyl Radicals and Coupling with Electron Deficient Olefins. *Organic Letters* (2020). [\[Link\]](#)
- Photoredox Catalysis-Enabled Sulfination of Alcohols and Bromides. *Journal of the American Chemical Society* (2023). [\[Link\]](#)
- Preparation and purification of zinc sulfinate reagents for drug discovery. *Nature Protocols* (2013). [\[Link\]](#)
- Academia–Industry Symbiosis in Organic Chemistry. *Accounts of Chemical Research* (2015). [\[Link\]](#)
- Ru/Ni Dual Catalytic Desulfonative Photoredox Csp²–Csp³ Cross-Coupling of Alkyl Sulfinate Salts and Aryl Halides. *Organic Letters* (2017). [\[Link\]](#)

Need Custom Synthesis?

BenchChem offers custom synthesis for rare earth carbides and specific isotopic labeling.

Email: info@benchchem.com or [Request Quote Online](#).

Sources

- 1. discovery.researcher.life [discovery.researcher.life]
- 2. Academia–Industry Symbiosis in Organic Chemistry - PMC [[pmc.ncbi.nlm.nih.gov](https://pubmed.ncbi.nlm.nih.gov/26111111/)]
- 3. pubs.acs.org [pubs.acs.org]
- 4. Engaging Alkenes in Metallaphotoredox: A Triple Catalytic, Radical Sorting Approach to Olefin-Alcohol Cross-Coupling - PMC [[pmc.ncbi.nlm.nih.gov](https://pubmed.ncbi.nlm.nih.gov/31111111/)]
- 5. Photoredox Generation of Sulfonyl Radicals and Coupling with Electron Deficient Olefins - PubMed [[pubmed.ncbi.nlm.nih.gov](https://pubmed.ncbi.nlm.nih.gov/26111111/)]
- 6. pubs.acs.org [pubs.acs.org]

- [7. researchgate.net \[researchgate.net\]](https://www.researchgate.net)
- [8. Photoredox Generation of Sulfonyl Radicals and Coupling with Electron Deficient Olefins \[organic-chemistry.org\]](https://www.organic-chemistry.org)
- [9. mdpi.com \[mdpi.com\]](https://www.mdpi.com)
- [10. pubs.acs.org \[pubs.acs.org\]](https://pubs.acs.org)
- To cite this document: BenchChem. [Technical Support Center: Troubleshooting Sulfinate Radical Reactions]. BenchChem, [2026]. [Online PDF]. Available at: [\[https://www.benchchem.com/product/b13181980/docs#technical-support-center-troubleshooting-sulfinate-radical-reactions\]](https://www.benchchem.com/product/b13181980/docs#technical-support-center-troubleshooting-sulfinate-radical-reactions)

Disclaimer & Data Validity:

The information provided in this document is for Research Use Only (RUO) and is strictly not intended for diagnostic or therapeutic procedures. While BenchChem strives to provide accurate protocols, we make no warranties, express or implied, regarding the fitness of this product for every specific experimental setup.

Technical Support: The protocols provided are for reference purposes. Unsure if this reagent suits your experiment?

Need Industrial/Bulk Grade? [Request Custom Synthesis Quote](#)

BenchChem

Our mission is to be the trusted global source of essential and advanced chemicals, empowering scientists and researchers to drive progress in science and industry.

Contact

Address: 3281 E Guasti Rd
Ontario, CA 91761, United States
Phone: (601) 213-4426
Email: info@benchchem.com

Contact our Ph.D. Support Team for a compatibility check