

# Optimizing Donor-Acceptor Distances with Dinitrophenylalanine: An Application & Protocol Guide

**Author:** BenchChem Technical Support Team. **Date:** May 2026

## Compound of Interest

Compound Name: *Boc-2,4-Dinitro-L-phenylalanine*

CAS No.: 1176509-56-0

Cat. No.: B1318699

[Get Quote](#)

For Researchers, Scientists, and Drug Development Professionals

## Authored by: Your Senior Application Scientist

### Abstract

This guide provides a comprehensive framework for utilizing Nε-2,4-dinitrophenyl-L-alanine (DNP-Ala), a non-fluorescent acceptor, to precisely measure and optimize intramolecular distances in peptides and proteins through Förster Resonance Energy Transfer (FRET). We delve into the core principles of FRET, the rationale behind employing DNP-Ala as a quencher, and provide detailed, field-proven protocols for the synthesis of DNP-labeled peptides, their purification, and subsequent spectroscopic analysis. This document is designed to equip researchers with the necessary knowledge to confidently design and execute FRET-based assays for applications ranging from enzymatic activity monitoring to the study of protein conformational changes, crucial for advancing drug discovery and development.

## Introduction: The Power of a Molecular Ruler

Förster Resonance Energy Transfer (FRET) is a powerful biophysical technique that functions as a "molecular ruler," enabling the measurement of distances between 1-10 nanometers[1]. This phenomenon involves the non-radiative transfer of energy from an excited donor fluorophore to a suitable acceptor molecule[2][3]. The efficiency of this energy transfer is exquisitely sensitive to the distance between the donor and acceptor, following an inverse sixth-power relationship[1][2]. This sensitivity makes FRET an invaluable tool for studying dynamic biological processes, including protein-protein interactions, protein folding, and enzymatic cleavage events[2][4].

Dinitrophenylalanine (DNP-Ala) serves as an excellent "dark" quencher or acceptor in FRET pairs. Its broad absorption spectrum effectively overlaps with the emission spectra of a variety of common donor fluorophores, while it does not emit fluorescence itself[5][6]. This eliminates the complication of acceptor emission crosstalk, simplifying data analysis and enhancing the sensitivity of the assay. This guide will focus on the practical application of DNP-Ala in optimizing donor-acceptor distances for robust and reliable FRET-based assays.

Diagram 1: The FRET Mechanism

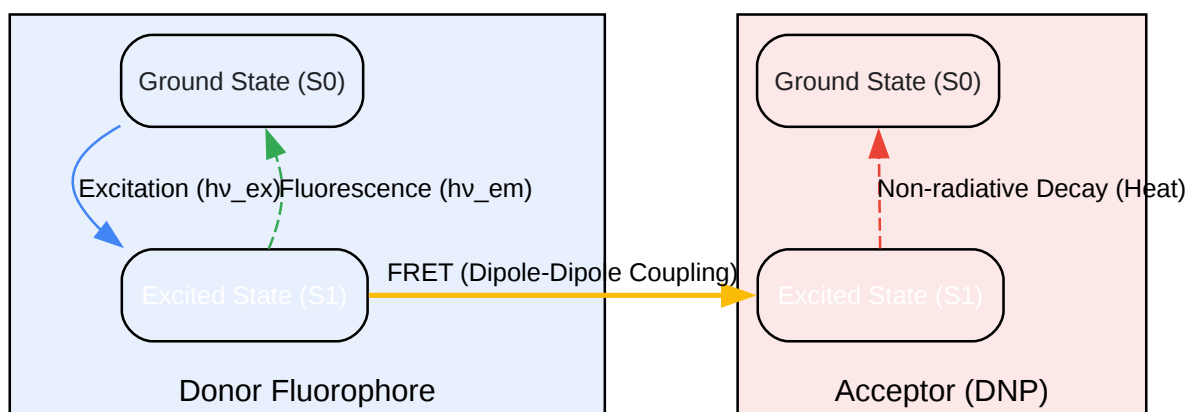

Diagram 1: The FRET Mechanism.

[Click to download full resolution via product page](#)

Caption: Energy transfer from an excited donor to the DNP acceptor.

## Experimental Design: Strategic Placement of Donor and Acceptor

The success of a FRET experiment hinges on the careful selection and placement of the donor and acceptor moieties within the peptide or protein of interest.

### Choosing the Right FRET Pair

The selection of a donor fluorophore to pair with DNP-Ala is critical and depends on several factors:

- **Spectral Overlap:** The emission spectrum of the donor must significantly overlap with the absorption spectrum of the DNP group for efficient energy transfer to occur[5][7].
- **Quantum Yield:** A donor with a high fluorescence quantum yield is desirable to maximize the dynamic range of the assay[8].
- **Solubility and Stability:** The chosen donor should be soluble in the assay buffer and stable under the experimental conditions.

Two commonly used and effective donors for pairing with DNP-Ala are Tryptophan (Trp), an intrinsic amino acid fluorophore, and 7-amino-4-carbamoylmethylcoumarin (ACC), a synthetic fluorophore.

### Data Presentation: Spectral Properties of Common DNP-Ala FRET Pairs

Donor	Excitation Max ( $\lambda_{ex}$ )	Emission Max ( $\lambda_{em}$ )	DNP Absorption Max ( $\lambda_{abs}$ )	Förster Distance ( $R_0$ )
Tryptophan (Trp)	~280 nm	~350 nm	~360 nm	~24.6 Å[9]
ACC	~360 nm	~440 nm	~360 nm	Variable

Note: The Förster distance ( $R_0$ ) is the distance at which FRET efficiency is 50% and is dependent on the specific donor-acceptor pair and their environment.

## Designing the Peptide/Protein Construct

The placement of the donor and DNP-Ala within the peptide sequence is paramount for probing the desired conformational change or cleavage event. For instance, in a protease activity assay, the donor and DNP-Ala are typically positioned on opposite sides of the cleavage site. In the intact peptide, they are in close proximity, leading to efficient quenching of the donor's fluorescence. Upon enzymatic cleavage, the donor and acceptor are separated, resulting in an increase in fluorescence.

Diagram 2: Protease Assay Workflow

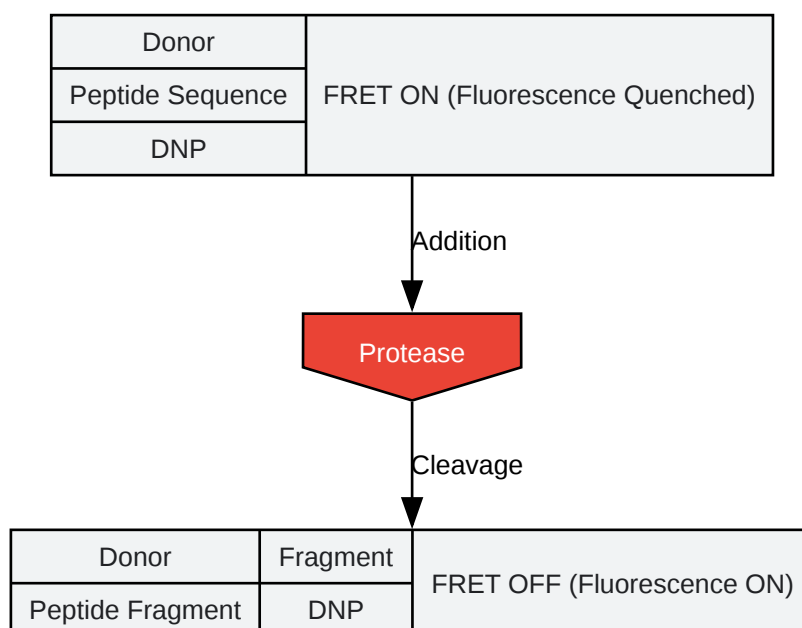

Diagram 2: Protease Assay Workflow.

[Click to download full resolution via product page](#)

Caption: Enzymatic cleavage separates the donor and DNP, restoring fluorescence.

## Experimental Protocols

The following protocols provide a detailed, step-by-step guide for the synthesis, purification, and analysis of DNP-labeled peptides for FRET applications.

## Protocol 1: Solid-Phase Peptide Synthesis (SPPS) of a DNP-Ala Containing Peptide

This protocol is based on the widely used Fmoc/tBu strategy[10][11].

### Materials:

- Fmoc-Rink Amide resin
- Fmoc-protected amino acids (including Fmoc-DNP-Ala-OH)
- Coupling reagent: HBTU (2-(1H-benzotriazol-1-yl)-1,1,3,3-tetramethyluronium hexafluorophosphate)
- Base: DIPEA (N,N-Diisopropylethylamine)
- Solvent: DMF (N,N-Dimethylformamide)
- Deprotection solution: 20% piperidine in DMF
- Cleavage cocktail: 95% TFA (Trifluoroacetic acid), 2.5% TIS (Triisopropylsilane), 2.5% H<sub>2</sub>O
- SPPS reaction vessel

### Procedure:

- Resin Swelling: Swell the Fmoc-Rink Amide resin in DMF for at least 30 minutes in the SPPS reaction vessel.
- Fmoc Deprotection:
  - Drain the DMF.
  - Add the deprotection solution (20% piperidine in DMF) to the resin and agitate for 5 minutes.
  - Drain the solution.

- Repeat the deprotection step with fresh solution for 15 minutes.
- Wash the resin thoroughly with DMF (5-7 times).
- Amino Acid Coupling:
  - In a separate vial, pre-activate the Fmoc-amino acid (3-5 equivalents relative to resin substitution) with HBTU (3-5 equivalents) and DIPEA (6-10 equivalents) in DMF for 5-10 minutes.
  - Add the activated amino acid solution to the deprotected resin.
  - Agitate the reaction mixture for 1-2 hours. For incorporating the bulky Fmoc-DNP-Ala-OH, a double coupling may be beneficial to ensure complete reaction[2].
  - Wash the resin thoroughly with DMF (5-7 times).
- Monitoring Coupling Efficiency: Perform a Kaiser test to confirm the absence of free primary amines, indicating a complete coupling reaction.
- Chain Elongation: Repeat steps 2-4 for each amino acid in the peptide sequence.
- Final Deprotection: After the final coupling step, perform a final Fmoc deprotection as described in step 2.
- Cleavage and Deprotection of Side Chains:
  - Wash the resin with DCM (Dichloromethane) and dry it under vacuum.
  - Add the cleavage cocktail to the resin and agitate for 2-3 hours at room temperature.
  - Filter the resin and collect the filtrate containing the cleaved peptide.
  - Precipitate the crude peptide by adding cold diethyl ether.
  - Centrifuge to pellet the peptide, decant the ether, and dry the peptide pellet under vacuum.

## Protocol 2: HPLC Purification of the DNP-Labeled Peptide

Reverse-phase high-performance liquid chromatography (RP-HPLC) is the standard method for purifying synthetic peptides[9][12].

Materials:

- RP-HPLC system with a C18 column
- Solvent A: 0.1% TFA in HPLC-grade water
- Solvent B: 0.1% TFA in HPLC-grade acetonitrile
- Crude DNP-labeled peptide

Procedure:

- **Sample Preparation:** Dissolve the crude peptide in a minimal amount of a suitable solvent (e.g., a mixture of Solvent A and Solvent B, or a small amount of DMSO followed by dilution with Solvent A). Filter the sample through a 0.22  $\mu\text{m}$  syringe filter.
- **Column Equilibration:** Equilibrate the C18 column with a low percentage of Solvent B (e.g., 5-10%) at a constant flow rate.
- **Gradient Elution:**
  - Inject the prepared peptide sample onto the column.
  - Apply a linear gradient of increasing Solvent B concentration over a set period (e.g., 5% to 65% B over 30 minutes). The optimal gradient will depend on the hydrophobicity of the peptide.
  - Monitor the elution of the peptide by absorbance at 220 nm (for the peptide backbone) and at the absorbance maximum of the DNP group (~360 nm).
- **Fraction Collection:** Collect fractions corresponding to the major peaks observed in the chromatogram.

- Purity Analysis: Analyze the purity of the collected fractions using analytical RP-HPLC and mass spectrometry to confirm the identity of the desired peptide.
- Lyophilization: Pool the pure fractions and lyophilize to obtain the purified peptide as a powder.

## Protocol 3: Spectroscopic Measurement of FRET Efficiency

### Materials:

- Fluorometer with excitation and emission monochromators
- Quartz cuvettes
- Purified DNP-labeled peptide (Donor-Acceptor construct)
- A control peptide lacking the DNP acceptor (Donor-only construct)
- Assay buffer

### Procedure:

- Instrument Setup:
  - Set the excitation wavelength to the absorbance maximum of the donor fluorophore.
  - Set the emission wavelength scan range to cover the entire emission spectrum of the donor.
- Measurement of Donor-Only Fluorescence:
  - Prepare a solution of the donor-only peptide in the assay buffer at a known concentration.
  - Record the fluorescence emission spectrum. The integrated fluorescence intensity of this spectrum represents  $F(D)$ .
- Measurement of Donor-Acceptor Fluorescence:

- Prepare a solution of the DNP-labeled peptide (donor-acceptor) at the same concentration as the donor-only peptide in the same assay buffer.
- Record the fluorescence emission spectrum under the same instrument settings. The integrated fluorescence intensity of this spectrum represents  $F(DA)$ .
- Calculation of FRET Efficiency (E):
  - The FRET efficiency can be calculated from the degree of donor fluorescence quenching using the following equation<sup>[13]</sup>:  $E = 1 - (F(DA) / F(D))$  Where:
    - E is the FRET efficiency
    - $F(DA)$  is the fluorescence intensity of the donor in the presence of the acceptor
    - $F(D)$  is the fluorescence intensity of the donor in the absence of the acceptor
- Calculation of Donor-Acceptor Distance (r):
  - The distance between the donor and acceptor can be calculated using the Förster equation:  $E = R_0^6 / (R_0^6 + r^6)$  Rearranging for r:  $r = R_0 * [(1/E) - 1]^{(1/6)}$  Where:
    - r is the donor-acceptor distance
    - $R_0$  is the Förster distance for the specific FRET pair

Diagram 3: FRET Data Analysis Workflow

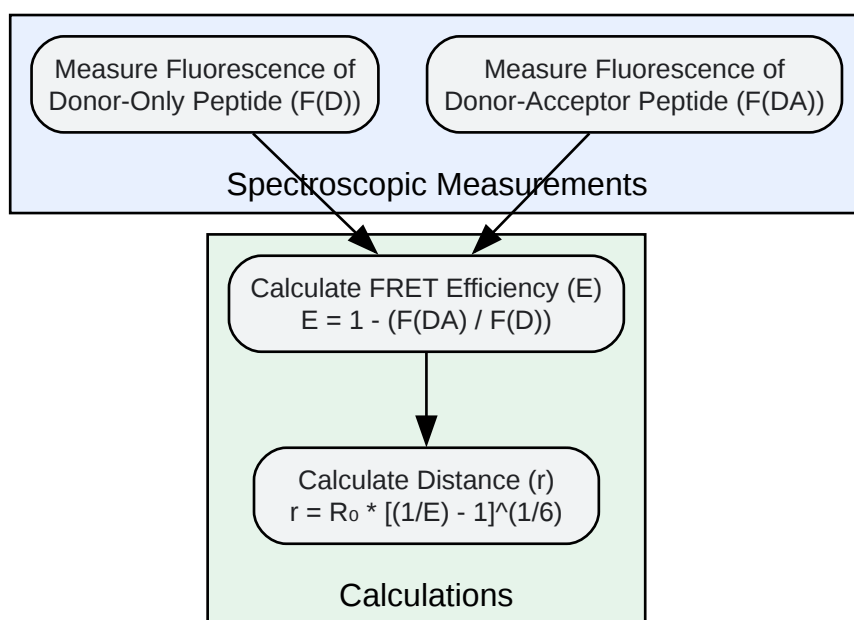

Diagram 3: FRET Data Analysis Workflow.

[Click to download full resolution via product page](#)

Caption: A streamlined workflow for FRET data analysis.

## Troubleshooting

Problem	Potential Cause(s)	Suggested Solution(s)
Low peptide yield in SPPS	Incomplete coupling, especially of bulky residues like DNP-Ala. Aggregation of the growing peptide chain.	Use a higher excess of amino acid and coupling reagents. Perform a double coupling for difficult residues[2]. Use a more polar solvent like NMP instead of DMF to improve solvation[14].
Multiple peaks in HPLC	Incomplete synthesis (truncated or deletion sequences). Side reactions during cleavage. Oxidation of sensitive residues (e.g., Met, Cys).	Optimize coupling and deprotection times during SPPS. Ensure the use of appropriate scavengers in the cleavage cocktail. Use fresh solvents and degas them before use.
Poor peak shape in HPLC for hydrophobic peptides	Peptide aggregation on the column. Poor solubility in the mobile phase.	Increase the column temperature to improve solubility and peak shape[15]. Dissolve the peptide in a small amount of DMSO or DMF before injection. Use a less hydrophobic column (e.g., C8 or C4).
Inconsistent FRET readings	Inaccurate concentration of peptide solutions. Photobleaching of the donor fluorophore. Cuvette contamination or improper handling.	Use a reliable method (e.g., UV-Vis absorbance) to accurately determine peptide concentrations. Minimize exposure of the sample to the excitation light. Thoroughly clean cuvettes and handle them only by the frosted sides.
Unexpectedly low or high FRET efficiency	Incorrect Förster distance ( $R_0$ ) used in calculations. Environmental effects on the	Ensure the $R_0$ value is appropriate for the specific donor-acceptor pair and experimental conditions.

fluorophore (pH, solvent polarity). Spectral crosstalk.

Maintain consistent buffer conditions. Perform control experiments to correct for any direct excitation of the acceptor or bleed-through of donor emission into the acceptor channel[1].

---

## Conclusion

The use of dinitrophenylalanine as a FRET acceptor provides a robust and reliable method for measuring intramolecular distances in peptides and proteins. By following the detailed protocols and troubleshooting guidance provided in this application note, researchers can confidently design and execute experiments to probe dynamic biological processes with high precision. The insights gained from these studies are invaluable for advancing our understanding of protein function and for the development of novel therapeutics.

## References

- Five Tips and Tricks for Success in Solid Phase Peptide Synthesis. Biotage. (2023-01-30). [\[Link\]](#)
- Förster resonance energy transfer - Wikipedia. [\[Link\]](#)
- Research Techniques Made Simple: Methodology and Applications of Förster Resonance Energy Transfer (FRET) Microscopy. PMC. [\[Link\]](#)
- Basics of FRET Microscopy. Nikon's MicroscopyU. [\[Link\]](#)
- Fluorescence Resonance Energy Transfer. [\[Link\]](#)
- Assessing Protein Interactions in Live-Cells with FRET-Sensitized Emission. JoVE. (2021-03-15). [\[Link\]](#)
- Solid-phase peptide synthesis: from standard procedures to the synthesis of difficult sequences. Springer Nature Experiments. [\[Link\]](#)

- Key Steps to Follow in a FRET Experiment. Spectroscopy Online. (2022-08-01). [\[Link\]](#)
- Tryptophan-based Fluorophores for Studying Protein Conformational Changes. PMC. [\[Link\]](#)
- What to do when your peptide synthesis fails? Biotage. (2023-02-07). [\[Link\]](#)
- A Guide to the Analysis and Purification of Proteins and Peptides by Reversed-Phase HPLC. [\[Link\]](#)
- Fmoc Solid-Phase Peptide Synthesis. PubMed. [\[Link\]](#)
- Peptide Isolation – Method Development Considerations. Waters Corporation. [\[Link\]](#)
- How can I get a proper HPLC for hydrophobic peptide? ResearchGate. (2014-02-09). [\[Link\]](#)
- FRET procedure. [\[Link\]](#)
- Highly sensitive and adaptable fluorescence-quenched pair discloses the substrate specificity profiles in diverse protease families. PMC. (2017-02-23). [\[Link\]](#)
- Intrinsic Tryptophan Fluorescence in the Detection and Analysis of Proteins: A Focus on Förster Resonance Energy Transfer Techniques. MDPI. [\[Link\]](#)
- PET and FRET Utility of an Amino Acid Pair: Tryptophan and 4-Cyanotryptophan. PMC. [\[Link\]](#)
- Multicolor Protein FRET with Tryptophan, Selective Coumarin-Cysteine Labeling, and Genetic Acridonylalanine Encoding. PMC. [\[Link\]](#)
- Technical note - Accurate FRET correction. Exciting Instruments. (2026-01-27). [\[Link\]](#)
- Spectrophotometer Troubleshooting: 15 Common Problems & Solutions. Hinotek. [\[Link\]](#)
- Overcoming Limitations of FRET Measurements. PMC. [\[Link\]](#)
- New FRET Pairs of Fluorescent Proteins for In Vitro Caspase Activity Determination. [\[Link\]](#)

- Schematic representation of the FRET peptide mechanism with the Abz/Dnp... | Download Scientific Diagram. ResearchGate. [[Link](#)]
- Enhancement of high-density lipoprotein-associated protease inhibitor activity prevents atherosclerosis progression. PMC. [[Link](#)]
- Tips for Using FRET in Your Experiments. Addgene Blog. (2014-11-05). [[Link](#)]

### Need Custom Synthesis?

BenchChem offers custom synthesis for rare earth carbides and specific isotopic labeling.

Email: [info@benchchem.com](mailto:info@benchchem.com) or [Request Quote Online](#).

## Sources

- 1. A Practical Guide to Single Molecule FRET - PMC [[pmc.ncbi.nlm.nih.gov](https://pubmed.ncbi.nlm.nih.gov)]
- 2. [biotage.com](https://biotage.com) [[biotage.com](https://biotage.com)]
- 3. The fluorescence laboratory. - Calculate Resonance Energy Transfer (FRET) Efficiencies [[fluortools.com](https://fluortools.com)]
- 4. [blog.mblintl.com](https://blog.mblintl.com) [[blog.mblintl.com](https://blog.mblintl.com)]
- 5. HPLC Analysis and Purification of Peptides - PMC [[pmc.ncbi.nlm.nih.gov](https://pubmed.ncbi.nlm.nih.gov)]
- 6. [bachem.com](https://bachem.com) [[bachem.com](https://bachem.com)]
- 7. PET and FRET Utility of an Amino Acid Pair: Tryptophan and 4-Cyanotryptophan - PMC [[pmc.ncbi.nlm.nih.gov](https://pubmed.ncbi.nlm.nih.gov)]
- 8. [pdf.benchchem.com](https://pdf.benchchem.com) [[pdf.benchchem.com](https://pdf.benchchem.com)]
- 9. [nestgrp.com](https://nestgrp.com) [[nestgrp.com](https://nestgrp.com)]
- 10. [laser.ceb.cam.ac.uk](https://laser.ceb.cam.ac.uk) [[laser.ceb.cam.ac.uk](https://laser.ceb.cam.ac.uk)]
- 11. [researchgate.net](https://researchgate.net) [[researchgate.net](https://researchgate.net)]
- 12. [biotage.com](https://biotage.com) [[biotage.com](https://biotage.com)]
- 13. [waters.com](https://waters.com) [[waters.com](https://waters.com)]
- 14. [researchgate.net](https://researchgate.net) [[researchgate.net](https://researchgate.net)]
- 15. [hinotek.com](https://hinotek.com) [[hinotek.com](https://hinotek.com)]

- To cite this document: BenchChem. [Optimizing Donor-Acceptor Distances with Dinitrophenylalanine: An Application & Protocol Guide]. BenchChem, [2026]. [Online PDF]. Available at: [<https://www.benchchem.com/product/b1318699/docs#optimizing-donor-acceptor-distances-with-dinitrophenylalanine-an-application-protocol-guide>]

---

### Disclaimer & Data Validity:

The information provided in this document is for Research Use Only (RUO) and is strictly not intended for diagnostic or therapeutic procedures. While BenchChem strives to provide accurate protocols, we make no warranties, express or implied, regarding the fitness of this product for every specific experimental setup.

**Technical Support:** The protocols provided are for reference purposes. Unsure if this reagent suits your experiment?

**Need Industrial/Bulk Grade?** [Request Custom Synthesis Quote](#)

## BenchChem

Our mission is to be the trusted global source of essential and advanced chemicals, empowering scientists and researchers to drive progress in science and industry.

### Contact

Address: 3281 E Guasti Rd  
Ontario, CA 91761, United States  
Phone: (601) 213-4426  
Email: [info@benchchem.com](mailto:info@benchchem.com)

[Contact our Ph.D. Support Team for a compatibility check](#)