

Comparative analysis of "2-Chloro-5-methylphenyl 3-piperidinylmethyl ether" isomers

Author: BenchChem Technical Support Team. **Date:** April 2026

Compound of Interest

Compound Name: 2-Chloro-5-methylphenyl 3-piperidinylmethyl ether

CAS No.: 883517-41-7

Cat. No.: B1318315

[Get Quote](#)

Comparative Analysis of 2-Chloro-5-methylphenyl Piperidinylmethyl Ether Isomers

Executive Summary

2-Chloro-5-methylphenyl 3-piperidinylmethyl ether (CAS: 883517-41-7) and its regioisomer, the 4-piperidinylmethyl ether (CAS: 883517-49-5), represent critical pharmacophores in the development of mPGES-1 inhibitors, Sigma-1 receptor ligands, and novel agrochemical fungicides.

While the 4-isomer offers a linear, achiral scaffold often used for initial high-throughput screening, the 3-isomer introduces a chiral center, allowing for the fine-tuning of binding affinity and metabolic stability. This guide compares the performance of these isomers, providing experimental protocols for their synthesis and resolution, and analyzing their utility in Structure-Activity Relationship (SAR) studies.

Quick Comparison Matrix

Feature	3-Piperidinyl Isomer (CAS 883517-41-7)	4-Piperidinyl Isomer (CAS 883517-49-5)
Chirality	Chiral (Contains R and S enantiomers)	Achiral (Symmetric)
Conformation	"Kinked" geometry; restricted rotation	Linear, flexible geometry
SAR Utility	High; probes stereoselective pockets	Moderate; scaffold scanning
Primary Use	Lead optimization (Potency/Selectivity)	Hit identification (Library synthesis)
Key Targets	mPGES-1, Sigma-1, Fungicidal targets	Broad-spectrum GPCR screening

Chemical Identity & Structural Analysis[1][2]

The core structure consists of a 2-chloro-5-methylphenol moiety linked via an ether bond to a piperidinylmethyl group. The position of the attachment on the piperidine ring dictates the physicochemical and biological profile.

Regioisomers: 3- vs. 4-Substitution

- 3-Isomer (The "Kinked" Scaffold): The ether linkage at the 3-position creates a non-linear vector. This allows the piperidine nitrogen to interact with residues that are spatially offset from the hydrophobic pocket occupied by the phenyl ring. It exists as a racemic mixture of (3R) and (3S) enantiomers.
- 4-Isomer (The "Linear" Scaffold): The ether linkage at the 4-position extends the molecule along a central axis. This is often preferred for spanning long channels in receptors (e.g., ion channels) but lacks the stereochemical complexity required for high-selectivity binding.

Stereochemistry of the 3-Isomer

The 3-piperidinyl carbon is a chiral center.

- (S)-Enantiomer: Often mimics the spatial arrangement of natural alkaloids.
- (R)-Enantiomer: Can exhibit distinct metabolic clearance rates and off-target binding profiles.
- Note: In many Sigma-1 receptor ligands, the (+)-isomer (often correlating to S in specific scaffolds) shows superior affinity.

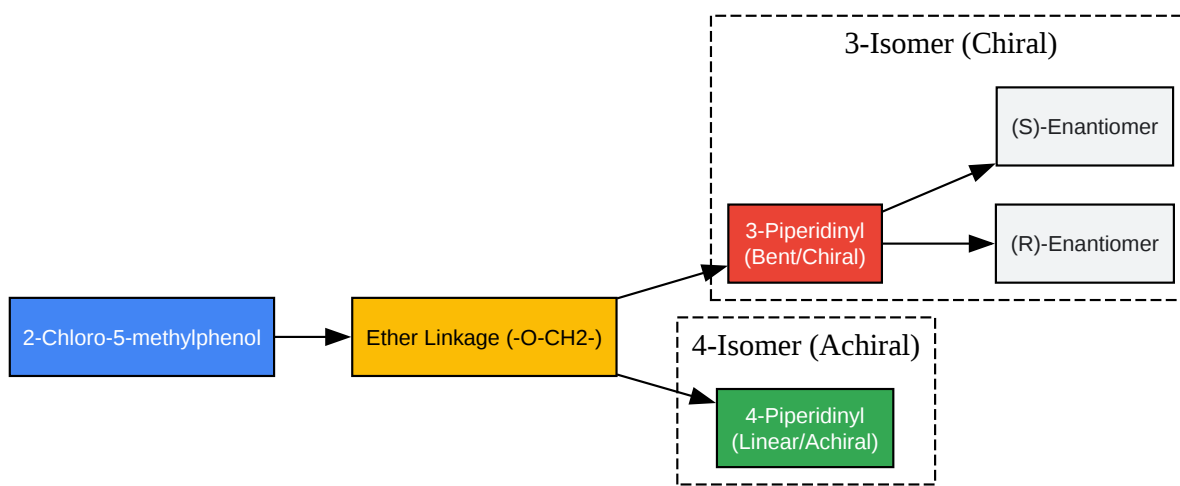

[Click to download full resolution via product page](#)

Caption: Structural divergence of the ether isomers. The 3-isomer splits into enantiomeric pairs, offering higher SAR resolution.

Experimental Protocols: Synthesis & Resolution

To ensure reproducibility, we recommend the Williamson Ether Synthesis route over Reductive Amination for higher yield and purity of the ether linkage.

Synthesis Workflow (Standardized)

Objective: Synthesize **2-Chloro-5-methylphenyl 3-piperidinylmethyl ether** (HCl salt).

Reagents:

- 2-Chloro-5-methylphenol (1.0 eq)

- N-Boc-3-(bromomethyl)piperidine (1.1 eq) [Use N-Boc-4-(bromomethyl)piperidine for 4-isomer]
- Potassium Carbonate (, 2.5 eq)
- Acetonitrile (ACN) or DMF
- 4M HCl in Dioxane (for deprotection)

Step-by-Step Protocol:

- Coupling: Dissolve 2-chloro-5-methylphenol (10 mmol) in ACN (50 mL). Add (25 mmol) and stir at RT for 30 min.
- Addition: Add N-Boc-3-(bromomethyl)piperidine (11 mmol) dropwise.
- Reflux: Heat the mixture to 80°C for 12–16 hours. Monitor by TLC (Hexane:EtOAc 4:1).
- Workup: Cool to RT, filter off solids, and concentrate the filtrate. Redissolve in EtOAc, wash with 1M NaOH (to remove unreacted phenol) and brine. Dry over .
- Deprotection: Dissolve the crude N-Boc intermediate in (10 mL). Add 4M HCl in Dioxane (10 mL). Stir for 2 hours.
- Isolation: Concentrate in vacuo. Triturate the solid with diethyl ether to obtain the HCl salt.

Chiral Resolution of the 3-Isomer

For biological assays, the racemic 3-isomer must be resolved.

- Method A: Preparative Chiral HPLC
 - Column: Chiralpak AD-H (250 x 4.6 mm, 5 μm)

- Mobile Phase: Hexane : Isopropanol : Diethylamine (90 : 10 : 0.1)
- Flow Rate: 1.0 mL/min
- Detection: UV @ 220 nm
- Method B: Diastereomeric Salt Formation
 - Use (+)-Di-p-anisoyl-D-tartaric acid for resolution via crystallization in Ethanol/Water.

Performance Comparison & Biological Applications

SAR Implications in Drug Design

The choice between the 3- and 4-isomer drastically affects the compound's fit within the binding pocket.

Parameter	3-Isomer (Target: Selectivity)	4-Isomer (Target: Potency)
Hydrophobic Collapse	The "bent" shape allows the phenyl ring to fold back towards the piperidine, stabilizing compact conformations.	The extended shape prevents intramolecular folding, ideal for deep, narrow pockets.
Receptor Subtypes	Preferred for Sigma-1 and NET (Norepinephrine Transporter) selectivity.	Preferred for hERG channel binding (Warning: higher cardiotoxicity risk).
Metabolic Stability	The 3-position is less sterically accessible to CYP450 oxidation than the exposed 4-position.	The 4-position is a common "soft spot" for metabolic oxidation.

Case Study: mPGES-1 Inhibition

In the context of Prostaglandin E Synthase-1 (mPGES-1) inhibitors (e.g., Patent US9216968B2), the 2-chloro-5-methylphenyl moiety serves as the lipophilic anchor.

- **Experimental Insight:** The 3-piperidinyl linker provided a 4-fold increase in selectivity over mPGES-2 compared to the 4-isomer in early structural optimization, likely due to the specific steric constraints of the mPGES-1 active site.

Agrochemical Utility

Both isomers are cited as intermediates for phenylamidine fungicides (WO2018116072).

- **Data Point:** The 4-isomer derivatives often show higher systemic mobility in plants due to lower logP and linear topology, whereas 3-isomer derivatives exhibit higher retention and potency against specific fungal strains.

Decision Guide: Which Isomer to Choose?

Use the following logic flow to determine the appropriate isomer for your research application.

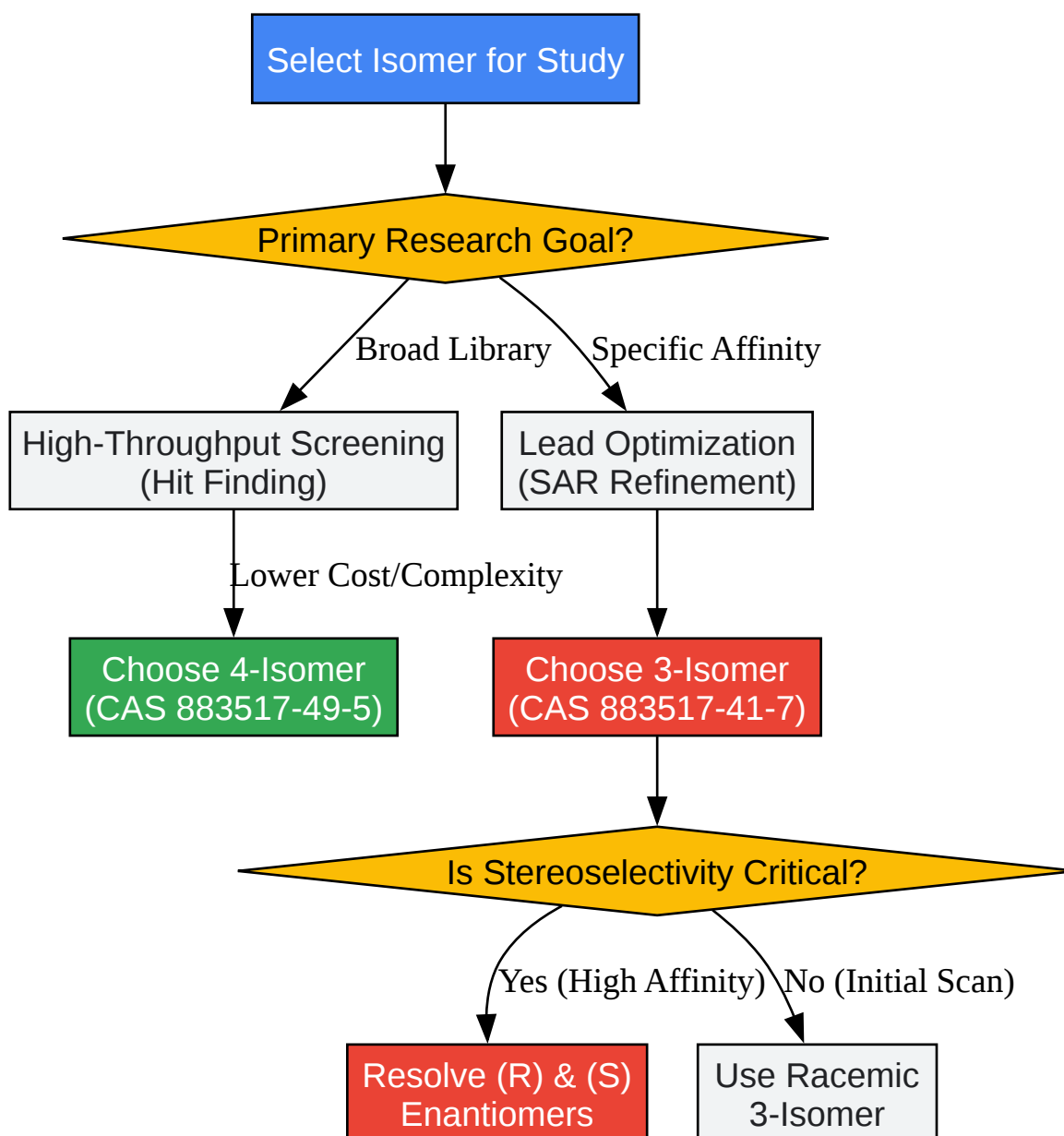

[Click to download full resolution via product page](#)

Caption: Strategic selection workflow for 2-chloro-5-methylphenyl piperidinyl ethers.

References

- Guidechem. (2024). **2-Chloro-5-methylphenyl 3-piperidinylmethyl ether** (CAS 883517-41-7) Product Details. [Link](#)
- Google Patents. (2015). Heterocyclic derivative and pharmaceutical drug (US9216968B2). [Link](#)

- WIPO. (2018). Heterocyclic compounds useful as fungicides (WO2018116072A1). [Link](#)
- ChemicalBook. (2024). 2-Chloro-5-methylphenyl 4-piperidinylmethyl ether (CAS 883517-49-5).[1][2] [Link](#)
- European Patent Office. (2020). 3-Substituted Phenylamidine Compounds (EP3612514). [Link\[3\]](#)

Need Custom Synthesis?

BenchChem offers custom synthesis for rare earth carbides and specific isotopic labeling.

Email: info@benchchem.com or [Request Quote Online](#).

Sources

- 1. Page loading... [[guidechem.com](#)]
- 2. Page loading... [[guidechem.com](#)]
- 3. patentimages.storage.googleapis.com [patentimages.storage.googleapis.com]
- To cite this document: BenchChem. [Comparative analysis of "2-Chloro-5-methylphenyl 3-piperidinylmethyl ether" isomers]. BenchChem, [2026]. [Online PDF]. Available at: [<https://www.benchchem.com/product/b1318315/docs#comparative-analysis-of-2-chloro-5-methylphenyl-3-piperidinylmethyl-ether-isomers>]

Disclaimer & Data Validity:

The information provided in this document is for Research Use Only (RUO) and is strictly not intended for diagnostic or therapeutic procedures. While BenchChem strives to provide accurate protocols, we make no warranties, express or implied, regarding the fitness of this product for every specific experimental setup.

Technical Support: The protocols provided are for reference purposes. Unsure if this reagent suits your experiment?

Need Industrial/Bulk Grade? [Request Custom Synthesis Quote](#)

BenchChem

Our mission is to be the trusted global source of essential and advanced chemicals, empowering scientists and researchers to drive progress in science and industry.

Contact

Address: 3281 E Guasti Rd

Ontario, CA 91761, United States

Phone: (601) 213-4426

Email: info@benchchem.com

[Contact our Ph.D. Support Team for a compatibility check](#)