

Navigating the Challenges of Regioisomer Formation in Pyrazole Synthesis: A Technical Guide

Author: BenchChem Technical Support Team. **Date:** April 2026

Compound of Interest

Compound Name: 1-Cyclobutyl-4-nitro-1H-pyrazole

Cat. No.: B13167481

[Get Quote](#)

For Researchers, Scientists, and Drug Development Professionals

Welcome to the Technical Support Center for Pyrazole Synthesis. This guide is designed to provide you with in-depth troubleshooting strategies and frequently asked questions regarding the control of regioisomer formation, a critical aspect of synthesizing substituted pyrazoles. As Senior Application Scientists, we understand that achieving high regioselectivity is paramount for the successful development of new chemical entities. This resource combines established chemical principles with practical, field-proven insights to help you navigate the complexities of pyrazole synthesis.

Frequently Asked Questions (FAQs)

Q1: What are regioisomers in the context of pyrazole synthesis, and why is their control so important?

A1: In pyrazole synthesis, particularly when using unsymmetrical 1,3-dicarbonyl compounds and substituted hydrazines, regioisomers are structural isomers that differ in the arrangement of substituents on the pyrazole ring.^[1] For instance, the reaction of 1-phenyl-1,3-butanedione

with methylhydrazine can produce two distinct products: 1,5-dimethyl-3-phenyl-1H-pyrazole and 1,3-dimethyl-5-phenyl-1H-pyrazole. The selective formation of one regioisomer is crucial because different regioisomers can possess vastly different biological activities, toxicological profiles, and physicochemical properties.[1] In drug discovery and materials science, the ability to produce a single, pure regioisomer is often a prerequisite for advancing a compound.

Q2: What are the fundamental factors that dictate regioselectivity in the Knorr pyrazole synthesis?

A2: The regiochemical outcome of the Knorr pyrazole synthesis, which involves the condensation of a 1,3-dicarbonyl compound with a hydrazine, is primarily governed by a delicate interplay of steric and electronic factors, as well as the reaction conditions.[1][2] Key influencers include:

- **Steric Hindrance:** Bulky substituents on the 1,3-dicarbonyl compound can physically obstruct the approach of the hydrazine, favoring its initial attack on the less sterically hindered carbonyl group.[1]
- **Electronic Effects:** The relative electrophilicity of the two carbonyl carbons is a major determinant. Electron-withdrawing groups can enhance the electrophilic character of a carbonyl carbon, making it a more likely target for the initial nucleophilic attack by the hydrazine.[1]
- **Reaction Conditions:** The choice of solvent, catalyst (acidic, basic, or neutral), and temperature can significantly influence the reaction pathway and, consequently, the ratio of regioisomers formed.[1][3]

Q3: How significantly can the choice of solvent affect the regioselectivity of my pyrazole synthesis?

A3: The choice of solvent can have a dramatic impact on regioselectivity. Solvents can influence the tautomeric equilibrium of the 1,3-dicarbonyl compound and the stability of reaction intermediates. For example, polar protic solvents can stabilize charged intermediates, potentially altering the reaction pathway. In some cases, switching to a more polar or a more coordinating solvent can invert the regioselectivity of the reaction.

Troubleshooting Guide: Addressing Regioisomer Formation

This section provides a structured approach to troubleshooting common issues related to regioisomer formation during pyrazole synthesis.

Issue 1: My reaction is producing a mixture of regioisomers with poor selectivity.

- Probable Cause: The electronic and steric differences between the two carbonyl groups of your 1,3-dicarbonyl substrate are not pronounced enough under the current reaction conditions to favor the formation of a single regioisomer. The reaction may be under thermodynamic control, leading to a mixture of products.
- Solutions:
 - Modify Reaction Temperature: Lowering the reaction temperature can favor kinetic control, potentially increasing the selectivity for one regioisomer. Conversely, increasing the temperature might favor the thermodynamically more stable product. A systematic temperature screen is recommended.
 - Solvent Screening: The polarity and coordinating ability of the solvent can influence the reaction pathway. Experiment with a range of solvents, from nonpolar (e.g., toluene, dioxane) to polar aprotic (e.g., DMF, DMSO) and polar protic (e.g., ethanol, isopropanol).
 - Catalyst Variation: The nature of the catalyst can significantly impact regioselectivity.
 - Acid Catalysis: Brønsted acids (e.g., acetic acid, p-toluenesulfonic acid) or Lewis acids can alter the electrophilicity of the carbonyl carbons.[\[4\]](#)
 - Base Catalysis: Bases can influence the nucleophilicity of the hydrazine and the enolate formation of the dicarbonyl compound.
 - Change the Order of Addition: In some cases, adding the hydrazine to the dicarbonyl compound slowly at a low temperature can improve selectivity.

Issue 2: The major product of my reaction is the undesired regioisomer.

- Probable Cause: The inherent electronic and steric properties of your starting materials favor the formation of the unwanted isomer under the current reaction conditions.
- Solutions:
 - Re-evaluate Starting Material Design: If possible, consider modifying the substituents on the 1,3-dicarbonyl compound to electronically or sterically favor the formation of the desired regioisomer. For example, introducing a bulky group can direct the initial attack to the less hindered carbonyl.
 - Alternative Synthetic Routes: Explore different synthetic strategies that offer better regiocontrol. For example, methods involving the cyclization of α,β -unsaturated ketones with hydrazines or 1,3-dipolar cycloadditions can sometimes provide complementary regioselectivity.^{[5][6]}
 - Stepwise Synthesis: In some cases, a stepwise approach where the hydrazone is first formed and isolated, followed by cyclization under different conditions, can provide better control over the regiochemical outcome.^[7]

Issue 3: I am observing inconsistent regioisomeric ratios between batches.

- Probable Cause: The reaction is highly sensitive to subtle variations in reaction conditions that are not being adequately controlled.
- Solutions:
 - Strict Control of Reaction Parameters: Ensure precise control over temperature, reaction time, and the rate of addition of reagents.
 - Purity of Reagents and Solvents: Use reagents and solvents of high purity. Impurities can sometimes act as catalysts or inhibitors, affecting the reaction outcome.
 - Atmosphere Control: If the reaction is sensitive to air or moisture, perform it under an inert atmosphere (e.g., nitrogen or argon).

Experimental Protocol: Regioselective Knorr Pyrazole Synthesis

This protocol provides a general method for the Knorr pyrazole synthesis, with specific considerations for controlling regioselectivity.

Materials:

- Unsymmetrical 1,3-dicarbonyl compound (1.0 eq)
- Substituted hydrazine (1.0-1.2 eq)
- Solvent (e.g., ethanol, acetic acid, or toluene)
- Catalyst (e.g., acetic acid, p-toluenesulfonic acid, or none)

Procedure:

- **Setup:** In a round-bottom flask equipped with a magnetic stirrer and a reflux condenser, dissolve the 1,3-dicarbonyl compound in the chosen solvent.
- **Reagent Addition:** Add the substituted hydrazine to the solution. If using a catalyst, add it at this stage.
- **Reaction:** Heat the reaction mixture to the desired temperature (e.g., reflux) and monitor the progress of the reaction by thin-layer chromatography (TLC) or liquid chromatography-mass spectrometry (LC-MS).
- **Work-up:** Once the reaction is complete, cool the mixture to room temperature. Remove the solvent under reduced pressure. The crude product can then be purified by recrystallization or column chromatography.
- **Characterization:** Characterize the product(s) by NMR spectroscopy (^1H , ^{13}C , and NOESY for determining regiochemistry), mass spectrometry, and other appropriate analytical techniques to determine the regioisomeric ratio.

Table 1: Influence of Reaction Conditions on Regioisomeric Ratio (Hypothetical Data)

| Entry | 1,3-Dicarbonyl | Hydrazine | Solvent | Catalyst | Temp (°C) | Ratio (A:B) |
|-------|-----------------------------------|-----------------|-------------|-------------|-----------|-------------|
| 1 | 1-Phenyl-1,3-butanedione | Methylhydrazine | Ethanol | None | 80 | 3:1 |
| 2 | 1-Phenyl-1,3-butanedione | Methylhydrazine | Acetic Acid | Acetic Acid | 100 | 1:5 |
| 3 | 1-Phenyl-1,3-butanedione | Methylhydrazine | Toluene | p-TSA | 110 | >95:5 |
| 4 | 1-(4-Nitrophenyl)-1,3-butanedione | Phenylhydrazine | Ethanol | None | 80 | 1:10 |

Visualizing the Reaction Pathway and Influencing Factors

The following diagram illustrates the general mechanism of the Knorr pyrazole synthesis and highlights the key factors that influence the formation of regioisomers.

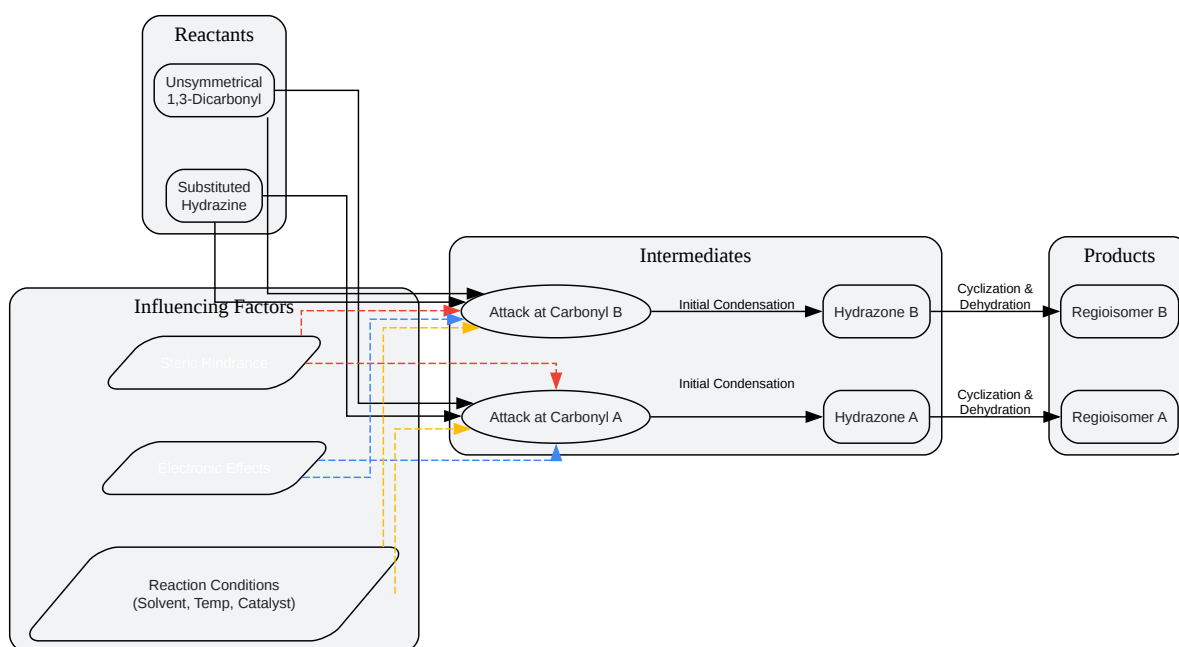

[Click to download full resolution via product page](#)

Caption: Factors influencing regioselectivity in Knorr pyrazole synthesis.

Troubleshooting Workflow

The following flowchart provides a systematic approach to troubleshooting poor regioselectivity in your pyrazole synthesis.

Caption: Troubleshooting workflow for poor regioselectivity in pyrazole synthesis.

References

- Pharmaguideline. Synthesis, Reactions and Medicinal Uses of Pyrazole. Available from: [\[Link\]](#)
- Organic Chemistry Portal. Pyrazole synthesis. Available from: [\[Link\]](#)
- PMC. Regioselective Synthesis, Structural Characterization, and Antiproliferative Activity of Novel Tetra-Substituted Phenylaminopyrazole Derivatives. Available from: [\[Link\]](#)
- PMC. Substituted Pyrazoles and Their Heteroannulated Analogs—Recent Syntheses and Biological Activities. Available from: [\[Link\]](#)
- PMC. Synthesis of Chromone-Related Pyrazole Compounds. Available from: [\[Link\]](#)
- Who we serve. An Efficient Synthesis of Substituted Pyrazoles from One-Pot Reaction of Ketones, Aldehydes, and Hydrazine Monohydrochloride. Available from: [\[Link\]](#)
- ResearchGate. Regiocontrol in the synthesis of 1,5- or 1,4-substituted pyrazoles 12–14 from enones 4. Available from: [\[Link\]](#)
- Synfacts. Aerobic Oxidative Cycloaddition Reactions for Pyrazole Synthesis. Available from: [\[Link\]](#)
- Encyclopedia.pub. Synthesis and Properties of Pyrazoles. Available from: [\[Link\]](#)
- ACS Publications. Regioselective Synthesis, NMR, and Crystallographic Analysis of N1-Substituted Pyrazoles. Available from: [\[Link\]](#)
- Taylor & Francis Online. Synthesis of polysubstituted pyrazoles and their biological applications. Available from: [\[Link\]](#)
- MDPI. Recent Advances in the Synthesis of Pyrazole Derivatives: A Review. Available from: [\[Link\]](#)
- RSC Publishing. Discovery of unexpectedly complex reaction pathways for the Knorr pyrazole synthesis via transient flow. Available from: [\[Link\]](#)

- ACS Publications. Synthesis of Pyrazoles via Electrophilic Cyclization. Available from: [\[Link\]](#)
- PMC. Multicomponent syntheses of pyrazoles via (3 + 2)-cyclocondensation and (3 + 2)-cycloaddition key steps. Available from: [\[Link\]](#)
- ACS Publications. Controlled Pyrazole-Hydrazone Annulation: Regiodivergent Synthesis of 1H- and 2H-Pyrazolo[3,4-d]pyridazinones. Available from: [\[Link\]](#)
- MDPI. Novel Regioselective Synthesis of 1,3,4,5-Tetrasubstituted Pyrazoles and Biochemical Valuation on F1FO-ATPase and Mitochondrial Permeability Transition Pore Formation. Available from: [\[Link\]](#)
- Knorr Pyrazole Synthesis. Knorr Pyrazole Synthesis. Available from: [\[Link\]](#)
- ResearchGate. Synthesis of polysubstituted pyrazoles from 1,3-dicarbonyl compounds. Available from: [\[Link\]](#)
- IntechOpen. Pyrazole Scaffold: Strategies toward the Synthesis and Their Applications. Available from: [\[Link\]](#)
- RSC Publishing. Iodine-promoted synthesis of pyrazoles from 1,3-dicarbonyl compounds and oxamic acid thiohydrazides. Available from: [\[Link\]](#)
- PMC. Leveraging the Knorr Pyrazole Synthesis for the Facile Generation of Thioester Surrogates for use in NCL. Available from: [\[Link\]](#)
- ResearchGate. Knorr pyrazole synthesis. Available from: [\[Link\]](#)

Need Custom Synthesis?

BenchChem offers custom synthesis for rare earth carbides and specific isotopic labeling.

Email: info@benchchem.com or [Request Quote Online](#).

Sources

- [1. pdf.benchchem.com](https://pdf.benchchem.com) [[pdf.benchchem.com](#)]

- [2. pdf.benchchem.com \[pdf.benchchem.com\]](https://pdf.benchchem.com)
- [3. Discovery of unexpectedly complex reaction pathways for the Knorr pyrazole synthesis via transient flow - Reaction Chemistry & Engineering \(RSC Publishing\)](#)
[DOI:10.1039/D2RE00271J \[pubs.rsc.org\]](https://doi.org/10.1039/D2RE00271J)
- [4. Recent Advances in the Synthesis of Pyrazole Derivatives: A Review | MDPI \[mdpi.com\]](#)
- [5. Synthesis of Chromone-Related Pyrazole Compounds - PMC \[pmc.ncbi.nlm.nih.gov\]](#)
- [6. Multicomponent syntheses of pyrazoles via \(3 + 2\)-cyclocondensation and \(3 + 2\)-cycloaddition key steps - PMC \[pmc.ncbi.nlm.nih.gov\]](#)
- [7. Regioselective Synthesis, Structural Characterization, and Antiproliferative Activity of Novel Tetra-Substituted Phenylaminopyrazole Derivatives - PMC \[pmc.ncbi.nlm.nih.gov\]](#)
- To cite this document: BenchChem. [Navigating the Challenges of Regioisomer Formation in Pyrazole Synthesis: A Technical Guide]. BenchChem, [2026]. [Online PDF]. Available at: [\[https://www.benchchem.com/product/b13167481/docs#navigating-the-challenges-of-regioisomer-formation-in-pyrazole-synthesis-a-technical-guide\]](https://www.benchchem.com/product/b13167481/docs#navigating-the-challenges-of-regioisomer-formation-in-pyrazole-synthesis-a-technical-guide)

Disclaimer & Data Validity:

The information provided in this document is for Research Use Only (RUO) and is strictly not intended for diagnostic or therapeutic procedures. While BenchChem strives to provide accurate protocols, we make no warranties, express or implied, regarding the fitness of this product for every specific experimental setup.

Technical Support: The protocols provided are for reference purposes. Unsure if this reagent suits your experiment?

Need Industrial/Bulk Grade? [Request Custom Synthesis Quote](#)

BenchChem

Our mission is to be the trusted global source of essential and advanced chemicals, empowering scientists and researchers to drive progress in science and industry.

Contact

Address: 3281 E Guasti Rd

Ontario, CA 91761, United States

Phone: (601) 213-4426

Email: info@benchchem.com

Contact our Ph.D. Support Team for a compatibility check