

Application Note: Precision Synthesis of Regioregular Substituted Polythiophenes

Author: BenchChem Technical Support Team. **Date:** April 2026

Compound of Interest

Compound Name: 2-Bromo-3-(2-butyloctyl)thiophene

Cat. No.: B13166053

[Get Quote](#)

Abstract

This guide provides a rigorous technical framework for the polymerization of substituted thiophenes, focusing on Poly(3-hexylthiophene) (P3HT) as the model system. We delineate three distinct methodologies: Grignard Metathesis (GRIM) for high-regioregularity (>98% Head-to-Tail) electronic-grade materials, Oxidative Polymerization (FeCl_3) for cost-effective bulk synthesis, and Electrochemical Polymerization for direct thin-film deposition. Emphasis is placed on the mechanistic control of regioregularity, molecular weight distribution (PDI), and post-synthesis purification to remove catalyst residues that act as charge traps.

Part 1: Strategic Method Selection

The choice of polymerization method dictates the electronic landscape of the final material.

Feature	GRIM (Kumada Catalyst Transfer)	Oxidative (FeCl ₃)	Electrochemical
Mechanism	Chain-Growth (Living)	Step-Growth	Radical Cation Coupling
Regioregularity (RR)	High (>98% HT)	Moderate (70–80% HT)	Variable (Solvent dependent)
Molecular Weight	Tunable (controlled by [M]/[Cat])	High, but uncontrolled	Insoluble films (Cross-linked)
PDI	Narrow (1.1 – 1.4)	Broad (> 2.0)	N/A (Film)
Primary Use Case	OFETs, OPVs (High Mobility)	Conductive Coatings, Antistatics	Sensors, Electrochromic Windows

Part 2: Protocol 1 - Regioregular GRIM Polymerization

Objective: Synthesis of electronic-grade P3HT with >98% Head-to-Tail (HT) coupling.

Mechanism: Nickel-catalyzed Kumada Catalyst Transfer Polycondensation (KCTP). The catalyst remains associated with the growing chain end ("ring-walking"), preventing chain transfer and ensuring a living polymerization.

Reagents & Equipment[1][2][3][4][5][6][7]

- Monomer: 2,5-dibromo-3-hexylthiophene (Purified by column chromatography; colorless oil).
- Catalyst: Ni(dppp)Cl₂ [1,3-Bis(diphenylphosphino)propane]dichloronickel(II).
- Grignard: tert-Butylmagnesium chloride (2.0 M in THF) or Methylmagnesium bromide.
- Solvent: Anhydrous THF (Distilled over Na/Benzophenone or from SPS).
- Setup: Schlenk line (Argon/Vacuum manifold), flame-dried glassware.

Step-by-Step Methodology

1. Monomer Activation (Grignard Metathesis)

- Context: This step determines the "Head" of the polymer. Kinetic control favors the 5-position magnesiation due to steric hindrance at the 2-position (adjacent to the hexyl chain).
- Protocol:
 - Load 2,5-dibromo-3-hexylthiophene (1.0 eq, e.g., 5.0 mmol) into a flame-dried Schlenk flask under Argon.
 - Add anhydrous THF (Concentration ~0.2 M).
 - Add t-BuMgCl (0.98 eq) dropwise at room temperature. Critical: Do not use excess Grignard; remaining R-MgX will react with the Ni catalyst, terminating chains or forming defects.
 - Stir for 1 hour. The solution typically turns yellow-green.

2. Polymerization (Catalysis)[\[1\]](#)[\[2\]](#)[\[3\]](#)[\[4\]](#)

- Protocol:
 - Dissolve Ni(dppp)Cl₂ in minimal anhydrous THF. Molar ratio determines MW:
.
 - Cannulate the catalyst solution into the activated monomer solution rapidly.
 - Observation: Color changes immediately to dark orange/red, then fluorescent purple/black as conjugation length increases.
 - Stir for 2–12 hours depending on target MW.

3. Quenching & Purification (The "Trap" Removal)

- Protocol:

- Quench with 5M HCl (aq) mixed with Methanol (1:5 ratio) to protonate the chain ends and solubilize Mg salts.
- Precipitate into excess cold Methanol. Filter the solid.[5][6][7]
- Soxhlet Extraction (Mandatory):
 - Thimble: Cellulose.
 - Solvent 1 (Methanol): Removes Mg salts and residual monomer (24h).
 - Solvent 2 (Hexanes): Removes low MW oligomers (regiorandom fractions).
 - Solvent 3 (Chloroform): Collects the high MW, high RR polymer.
- Concentrate the Chloroform fraction and re-precipitate in Methanol. Dry under high vacuum.

Visualization: GRIM Catalytic Cycle

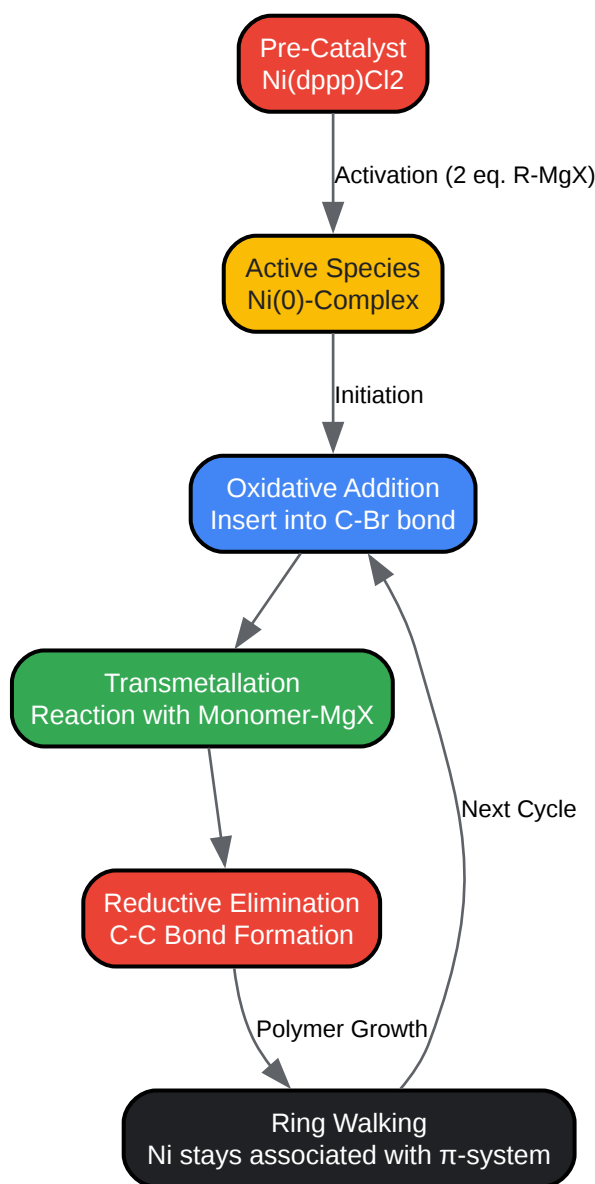

[Click to download full resolution via product page](#)

Caption: The "Ring Walking" mechanism (bottom) is critical for living polymerization, preventing the catalyst from diffusing away and initiating new chains.

Part 3: Protocol 2 - Oxidative Polymerization (FeCl_3)

Objective: Rapid synthesis of P3HT for applications where ultra-high mobility is secondary to cost (e.g., antistatic coatings).

Reagents

- Monomer: 3-hexylthiophene.[\[1\]](#)[\[2\]](#)[\[7\]](#)[\[8\]](#)[\[9\]](#)
- Oxidant: Anhydrous FeCl_3 (Must be handled in a glovebox or dry box; hygroscopic FeCl_3 kills the reaction).
- Solvent: Dry Chloroform or Chlorobenzene.

Protocol

- Slurry Preparation: Suspend anhydrous FeCl_3 (4.0 eq) in dry Chloroform in a Schlenk flask under Argon.
- Addition: Add 3-hexylthiophene (1.0 eq) dropwise. The reaction is exothermic; slow addition prevents cross-linking.
- Reaction: Stir for 2–24 hours. Bubbling Argon helps remove generated HCl gas (which can induce side reactions).
- Reduction: The polymer forms in its oxidized (doped) state (insoluble black solid). Add Methanol/Hydrazine or Methanol/Ammonia to reduce it to the neutral, soluble (orange/red) state.
- Purification: Extensive washing with Methanol is required to remove trapped Iron ions, which quench fluorescence and reduce device stability.

Part 4: Protocol 3 - Electrochemical Polymerization

Objective: Direct deposition of insoluble, cross-linked films onto conductive substrates (ITO, Au).

Setup

- Working Electrode (WE): Indium Tin Oxide (ITO) coated glass or Gold slide.
- Counter Electrode (CE): Platinum wire/mesh.
- Reference Electrode (RE): Ag/Ag^+ (0.01 M AgNO_3 in ACN).

- Electrolyte: 0.1 M Tetrabutylammonium hexafluorophosphate (TBAPF₆) in Acetonitrile/DCM (1:1).

Protocol

- Solution: Dissolve monomer (10–50 mM) in the electrolyte solution.
- Technique: Cyclic Voltammetry (CV) or Potentiostatic mode.
 - CV: Scan from -0.2 V to +1.5 V vs Ag/Ag⁺ at 50 mV/s.
 - Observation: "Nucleation loop" on first scan; current increases with each cycle as the conductive film grows.
- Control: Film thickness is directly proportional to the total charge passed (Coulometry).
- Post-Process: Rinse electrode with monomer-free Acetonitrile to remove oligomers.

Visualization: Electrochemical Cell Setup

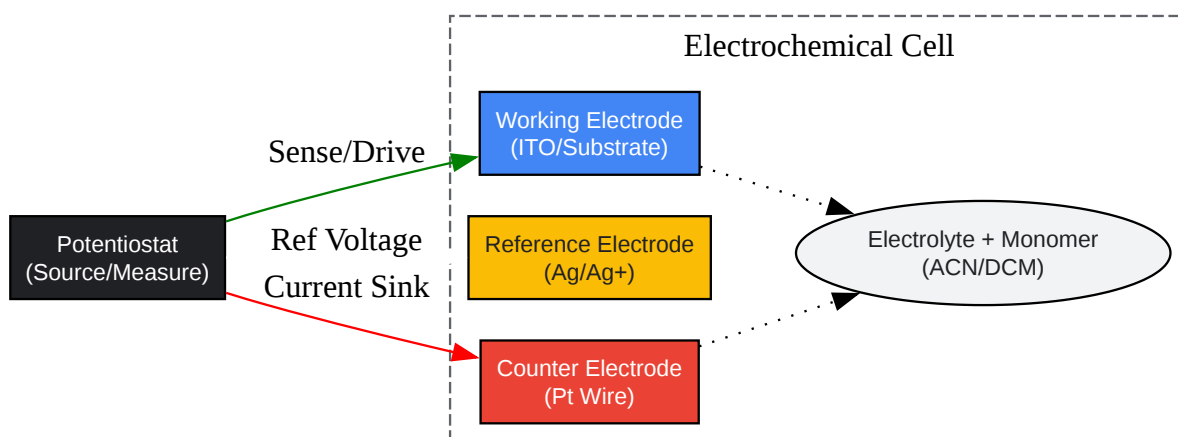

[Click to download full resolution via product page](#)

Caption: Standard 3-electrode configuration. The potential is controlled between WE and RE, while current flows between WE and CE.

Part 5: Quality Control & Characterization

Regioregularity (NMR)

The most critical metric for GRIM-synthesized P3HT.

- Method: ^1H NMR (500 MHz, CDCl_3).
- Signals: Focus on the
 - methylene protons (the first CH_2 of the hexyl chain).
 - Head-to-Tail (HT):
ppm (Desired).
 - Head-to-Head (HH):
ppm (Defect).
- Calculation:
Target: >98% for electronic applications.

Molecular Weight (GPC)

- Standard: Polystyrene standards are commonly used, but they overestimate P3HT molecular weight by factor of ~1.5–2 due to the rigid rod nature of P3HT.
- Correction: Use Malvern or Universal Calibration if possible.

Troubleshooting Table

Issue	Probable Cause	Corrective Action
Low Molecular Weight	Catalyst "death" or excess Grignard	Ensure [Monomer]/[Ni] ratio is correct. Do not add >1.0 eq Grignard during activation.
Broad PDI (>1.5)	Slow initiation	Use an external initiator or ensure rapid injection of catalyst.
Low Regioregularity	"Scrambling" during activation	Keep activation temp < 25°C. Reaction time < 2h for activation.
Insoluble Polymer	Cross-linking (FeCl ₃ method)	Reduce concentration, lower temperature, or switch to GRIM.

References

- McCullough, R. D., et al. "Self-orienting head-to-tail poly(3-alkylthiophenes): new insights on structure-property relationships in conducting polymers." *Journal of the American Chemical Society*, 115(11), 4910–4911. [Link](#)
- Loewe, R. S., & McCullough, R. D. "A Simple Method to Prepare Head-to-Tail Coupled, Regioregular Poly(3-alkylthiophenes) Using Grignard Metathesis." *Advanced Materials*, 11(3), 250–253. [Link](#)
- Yokozawa, T., & Ohta, Y. "Transformation of Step-Growth Polymerization into Living Chain-Growth Polymerization." *Chemical Reviews*, 116(4), 1950–1968. [Link](#)
- Sugimoto, R., et al. "Preparation of soluble polythiophene derivatives utilizing transition metal halides as catalysts and their property." *Chemistry Express*, 1(11), 635-638. (Seminal work on FeCl₃ method).
- Roncali, J. "Conjugated poly(thiophenes): synthesis, functionalization, and applications." *Chemical Reviews*, 92(4), 711–738. [Link](#)

Need Custom Synthesis?

BenchChem offers custom synthesis for rare earth carbides and specific isotopic labeling.

Email: info@benchchem.com or [Request Quote Online](#).

Sources

- [1. chem.cmu.edu](http://chem.cmu.edu) [chem.cmu.edu]
- [2. Controlled synthesis of poly\(3-hexylthiophene\) in continuous flow - PMC](#) [pmc.ncbi.nlm.nih.gov]
- [3. Enabling Conducting Polymer Applications: Methods for Achieving High Molecular Weight in Chemical Oxidative Polymerization in Alkyl- and Ether-Substituted Thiophenes - PMC](#) [pmc.ncbi.nlm.nih.gov]
- [4. Chiral Polythiophenes: Part I: Syntheses of Monomeric Precursors - PMC](#) [pmc.ncbi.nlm.nih.gov]
- [5. faculty.uobasrah.edu.iq](http://faculty.uobasrah.edu.iq) [faculty.uobasrah.edu.iq]
- [6. mdpi.com](http://mdpi.com) [mdpi.com]
- [7. kutarr.kochi-tech.ac.jp](http://kutarr.kochi-tech.ac.jp) [kutarr.kochi-tech.ac.jp]
- [8. pubs.acs.org](http://pubs.acs.org) [pubs.acs.org]
- [9. The McCullough Group - Research](#) [chem.cmu.edu]
- To cite this document: BenchChem. [Application Note: Precision Synthesis of Regioregular Substituted Polythiophenes]. BenchChem, [2026]. [Online PDF]. Available at: [<https://www.benchchem.com/product/b13166053/docs#application-note-precision-synthesis-of-regioregular-substituted-polythiophenes>]

Disclaimer & Data Validity:

The information provided in this document is for Research Use Only (RUO) and is strictly not intended for diagnostic or therapeutic procedures. While BenchChem strives to provide accurate protocols, we make no warranties, express or implied, regarding the fitness of this product for every specific experimental setup.

Technical Support: The protocols provided are for reference purposes. Unsure if this reagent suits your experiment?

Need Industrial/Bulk Grade? [Request Custom Synthesis Quote](#)

BenchChem

Our mission is to be the trusted global source of essential and advanced chemicals, empowering scientists and researchers to drive progress in science and industry.

Contact

Address: 3281 E Guasti Rd
Ontario, CA 91761, United States
Phone: (601) 213-4426
Email: info@benchchem.com

[Contact our Ph.D. Support Team for a compatibility check](#)