

Spectroscopic Characterization of Aryl Carboxylic Acid Alkynes: A Comparative IR Guide

Author: BenchChem Technical Support Team. **Date:** May 2026

Compound of Interest

Compound Name: *(4-Chloro-2-fluoro-phenyl)-propynoic acid*

Cat. No.: B13165693

[Get Quote](#)

Executive Summary

This guide provides a technical breakdown of the infrared (IR) absorption characteristics of aryl carboxylic acid alkynes (e.g., phenylpropionic acid derivatives). These compounds are unique because they possess a conjugated system linking an electron-rich aromatic ring, an electron-transporting alkyne spacer, and an electron-withdrawing carboxylic acid.

Correctly interpreting their IR spectra requires distinguishing them from structural isomers (e.g., ethynylbenzoic acids) and related precursors. This guide focuses on the diagnostic utility of the alkyne stretching frequency (

) and its intensity amplification due to the "push-pull" electronic environment.

The Spectroscopic Fingerprint

The IR spectrum of an aryl carboxylic acid alkyne is dominated by three primary regions. The interplay between these groups defines the molecule's unique signature.

A. The "Invisible" Alkyne Made Visible

In dialkyl alkynes, the

stretch ($2100\text{--}2260\text{ cm}^{-1}$) is often weak or forbidden due to symmetry. However, in aryl carboxylic acid alkynes, the alkyne acts as a bridge between the aryl ring and the carbonyl group.

- Frequency: $2200\text{--}2250\text{ cm}^{-1}$ [1]
- Intensity: Medium to Strong (Diagnostic).
- Mechanism: The strong dipole moment change induced by the electron-withdrawing carboxyl group ($-\text{COOH}$) breaks the symmetry, making this band highly active.

B. The Carboxylic Acid Dimer

Unless measured in extremely dilute solution, the carboxylic acid exists as a hydrogen-bonded dimer.[2]

- (Stretch): $2500\text{--}3300\text{ cm}^{-1}$ (Very broad, often described as a "hairy beard" overlapping C-H stretches).
- (Stretch): $1680\text{--}1710\text{ cm}^{-1}$.
 - Note: This is lower than non-conjugated aliphatic acids ($\sim 1710\text{--}1725\text{ cm}^{-1}$) due to conjugation with the alkyne and aryl ring.

C. The Aryl Ring[3][4][5]

- (Ring Breathing): $\sim 1450, 1500, 1580, 1600\text{ cm}^{-1}$.
- OOP (Out-of-Plane) Bending: $680\text{--}900\text{ cm}^{-1}$ (Critical for determining substitution patterns, e.g., mono-, meta-, or para-substitution).

Comparative Analysis: Structural Isomers & Analogs

The following table contrasts the target compound class with its closest structural analogs to highlight diagnostic peaks.

Feature	Phenylpropionic Acid (Target)	4-Ethynylbenzoic Acid (Isomer)	Benzoic Acid (Analog)
Structure	Ph-C≡C-COOH	H-C≡C-Ph-COOH	Ph-COOH
Alkyne Type	Internal, Conjugated	Terminal, Conjugated to Ring	None
	2200–2240 cm ⁻¹ (Med/Strong)	2100–2150 cm ⁻¹ (Weak/Med)	Absent
	Absent	~3250–3350 cm ⁻¹ (Sharp)	Absent
	1680–1700 cm ⁻¹	1680–1700 cm ⁻¹	1680–1700 cm ⁻¹
	2500–3300 cm ⁻¹ (Broad)	2500–3300 cm ⁻¹ (Broad)	2500–3300 cm ⁻¹ (Broad)
Diagnostic Note	Strong internal alkyne peak due to asymmetry.[3][4][5][6]	Sharp terminal C-H peak is the key differentiator.	Lack of region 2100- 2300 peaks.[7]

Mechanistic Logic Flow

The following diagram illustrates the decision process for identifying these compounds based on spectral data.

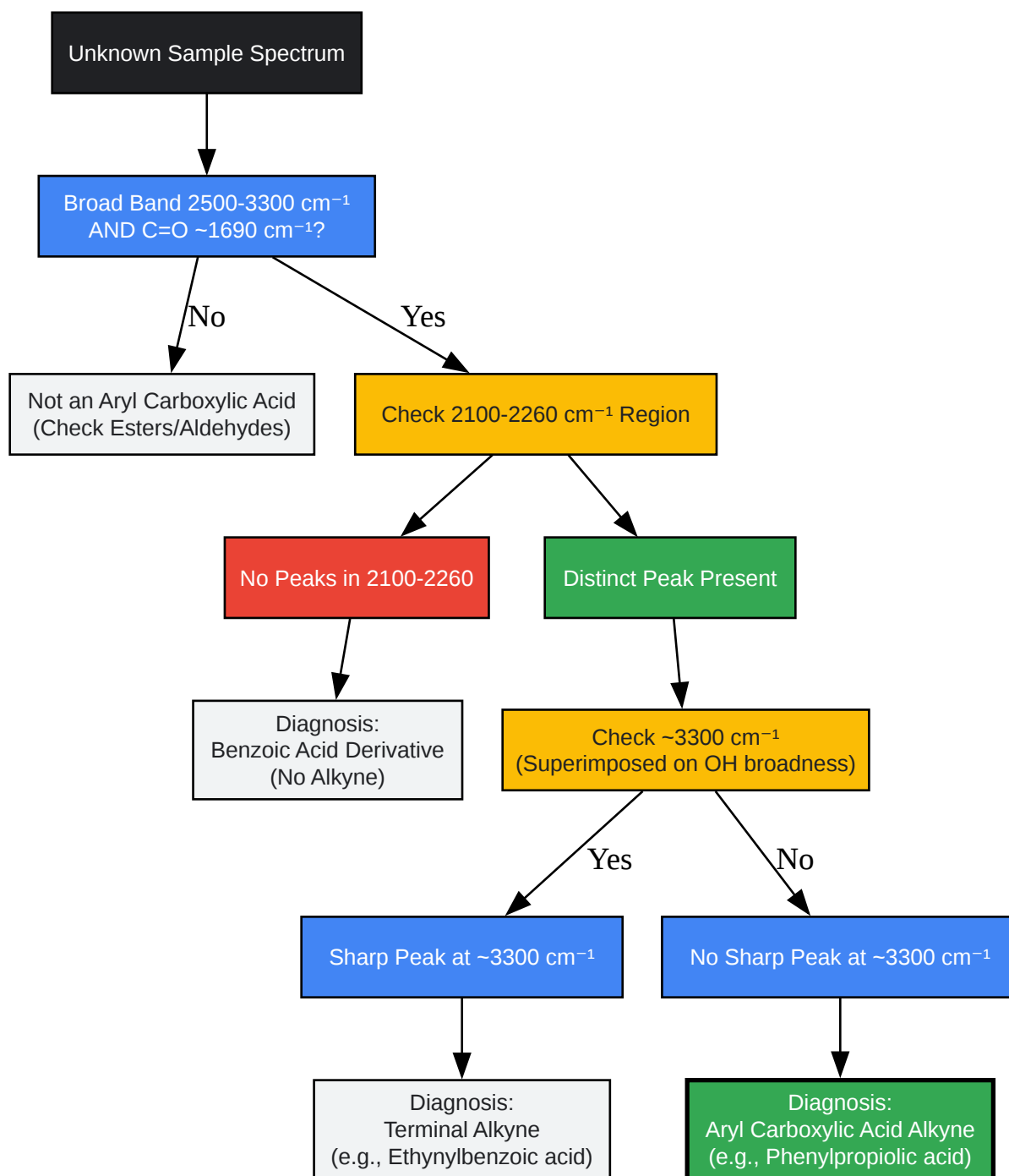

[Click to download full resolution via product page](#)

Figure 1: Logical decision tree for distinguishing aryl carboxylic acid alkynes from isomers and analogs.

Mechanistic Insights: The Conjugation Effect

Understanding why the peaks shift is crucial for validating your data.

- The "Push-Pull" System: In phenylpropionic acid, the alkyne is sandwiched between a donor (Phenyl ring) and an acceptor (Carboxyl).

This creates a strong dipole along the molecular axis. According to the selection rules of IR spectroscopy, the intensity of an absorption band is proportional to the square of the change in dipole moment (

). Therefore, unlike the weak stretch in diphenylacetylene (symmetric), the stretch here is intensified.

- Frequency Lowering: Conjugation delocalizes the π -electrons. This reduces the bond order of the triple bond slightly (more single-bond character), lowering the vibrational frequency from $\sim 2260\text{ cm}^{-1}$ (isolated) to $\sim 2200\text{-}2230\text{ cm}^{-1}$.

Experimental Protocol: Sample Preparation

To obtain the high-resolution spectra required to see the "hairy beard" of the OH dimer and the sharp alkyne peak, specific preparation is required.

Method A: KBr Pellet (Gold Standard for Solids)

Recommended for resolution of the fingerprint region.

- Grinding: Mix 1-2 mg of the dry aryl carboxylic acid alkyne with ~ 100 mg of spectroscopic grade KBr.
- Pulverization: Grind in an agate mortar until a fine, flour-like consistency is achieved. Crucial: Coarse particles cause light scattering (Christiansen effect), distorting the baseline.
- Compression: Press at 8-10 tons for 1-2 minutes to form a transparent pellet.
- Measurement: Scan from 4000 to 400 cm^{-1} .
 - Validation: The O-H band should be broad but smooth. Noise in the $2000\text{-}2500\text{ cm}^{-1}$ region suggests moisture contamination in the KBr.

Method B: ATR (Attenuated Total Reflectance)

Recommended for rapid screening.

- Crystal Selection: Use a Diamond or ZnSe crystal.
- Application: Place solid sample directly on the crystal.
- Pressure: Apply maximum pressure using the anvil to ensure intimate contact.
 - Note: ATR often shifts peaks slightly ($1-2\text{ cm}^{-1}$) lower than transmission modes and changes relative intensities.

Workflow Diagram

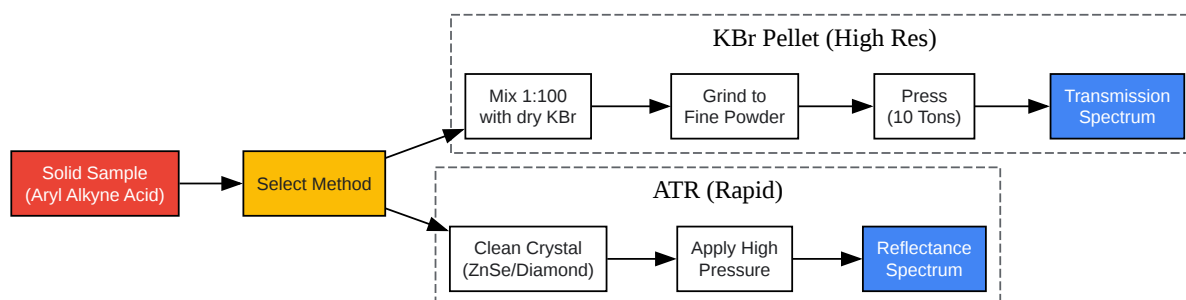

[Click to download full resolution via product page](#)

Figure 2: Experimental workflow for KBr vs. ATR sampling.

References

- NIST Mass Spectrometry Data Center. Phenylpropionic acid Infrared Spectrum. NIST Standard Reference Database 69: NIST Chemistry WebBook. [5][8] Retrieved from [Link]
- LibreTexts Chemistry. Spectroscopy of Carboxylic Acids and Nitriles. (2024). Retrieved from [Link]

- PubChem.4-Ethynylbenzoic acid | C₉H₆O₂.^[9] National Library of Medicine. Retrieved from [\[Link\]](#)
- UCLA Chemistry & Biochemistry.Table of Characteristic IR Absorptions. Retrieved from [\[Link\]](#)
- Doc Brown's Chemistry.Interpretation of the infrared spectrum of benzoic acid. Retrieved from [\[Link\]](#)

Need Custom Synthesis?

BenchChem offers custom synthesis for rare earth carbides and specific isotopic labeling.

Email: info@benchchem.com or [Request Quote Online](#).

Sources

- 1. chem.libretexts.org [chem.libretexts.org]
- 2. orgchemboulder.com [orgchemboulder.com]
- 3. orgchemboulder.com [orgchemboulder.com]
- 4. IR Absorption Table [webspectra.chem.ucla.edu]
- 5. Phenylpropionic acid [webbook.nist.gov]
- 6. Ethylphenylpropionate [webbook.nist.gov]
- 7. faculty.ksu.edu.sa [faculty.ksu.edu.sa]
- 8. Phenylpropionic acid [webbook.nist.gov]
- 9. 4-Ethynylbenzoic acid | C₉H₆O₂ | CID 589706 - PubChem [pubchem.ncbi.nlm.nih.gov]
- To cite this document: BenchChem. [Spectroscopic Characterization of Aryl Carboxylic Acid Alkynes: A Comparative IR Guide]. BenchChem, [2026]. [Online PDF]. Available at: [<https://www.benchchem.com/product/b13165693/docs#spectroscopic-characterization-of-aryl-carboxylic-acid-alkynes-a-comparative-ir-guide>]

Disclaimer & Data Validity:

The information provided in this document is for Research Use Only (RUO) and is strictly not intended for diagnostic or therapeutic procedures. While BenchChem strives to provide

accurate protocols, we make no warranties, express or implied, regarding the fitness of this product for every specific experimental setup.

Technical Support: The protocols provided are for reference purposes. Unsure if this reagent suits your experiment?

Need Industrial/Bulk Grade? [Request Custom Synthesis Quote](#)

BenchChem

Our mission is to be the trusted global source of essential and advanced chemicals, empowering scientists and researchers to drive progress in science and industry.

Contact

Address: 3281 E Guasti Rd
Ontario, CA 91761, United States
Phone: (601) 213-4426
Email: info@benchchem.com

[Contact our Ph.D. Support Team for a compatibility check](#)