

resolving 4-Chloro-7-methoxy-1-indanone purification issues

Author: BenchChem Technical Support Team. **Date:** May 2026

Compound of Interest

Compound Name: 4-Chloro-7-methoxy-1-indanone

CAS No.: 99183-99-0

Cat. No.: B1316982

[Get Quote](#)

Technical Support Center: 4-Chloro-7-methoxy-1-indanone

Topic: Troubleshooting Purification & Isolation Issues Document ID: TS-IND-4C7M-01 Last Updated: 2024-05-22[1]

Diagnostic Workflow: The "Triage" Phase

Before attempting remediation, you must identify the nature of your impurity profile. The synthesis of **4-Chloro-7-methoxy-1-indanone** (typically via intramolecular Friedel-Crafts cyclization of 3-(2-chloro-5-methoxyphenyl)propanoic acid) generates a specific set of byproducts due to the competing electronic effects of the Chlorine (deactivating) and Methoxy (activating) groups.[1]

Impurity Identification Matrix

Observation (TLC/HPLC)	Probable Impurity	Root Cause
Lower spot (More polar)	4-Chloro-7-hydroxy-1-indanone	Demethylation: Lewis acid (e.g.,) was too harsh or reaction temp was too high.[1]
Higher spot (Less polar)	Uncyclized Ester/Chloride	Incomplete Reaction: Moisture in Lewis acid or insufficient catalyst equivalents.[1]
Close-running spot	5-Chloro-4-methoxy isomer	Regioisomerism: Only occurs if the starting material substitution pattern allowed cyclization at two positions (unlikely with 2-chloro-5-methoxy precursors but possible with other routes).[1]
Baseline smear / Dark Oil	Polymeric Tars	Over-reaction: Reaction time too long; susceptible to oxidative polymerization.

Visualizing the Impurity Pathways

The following diagram illustrates where these impurities originate during the standard synthetic workflow.

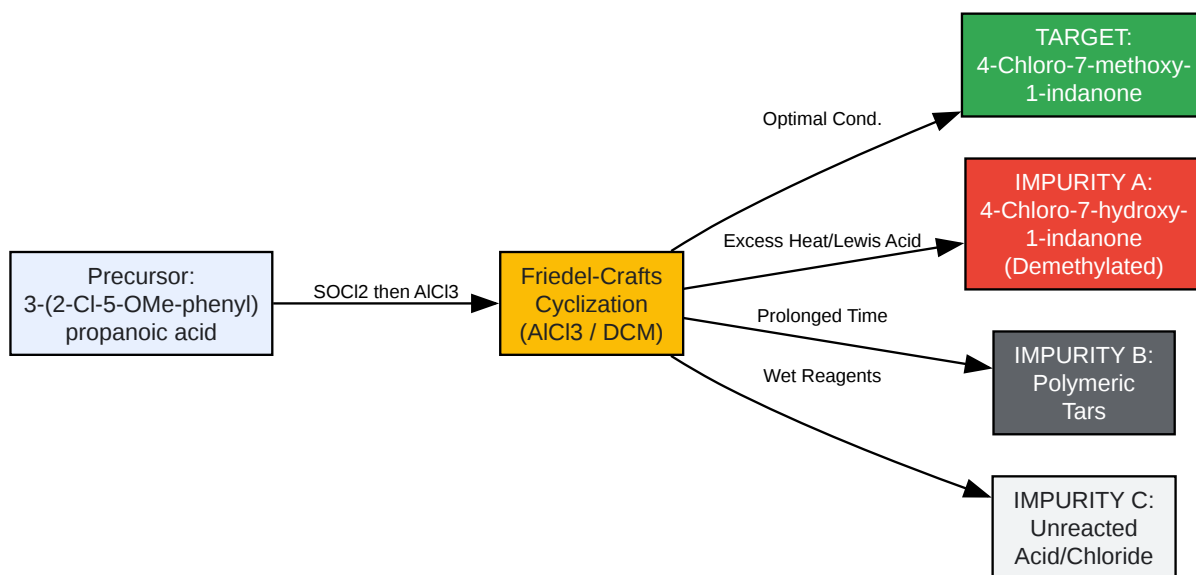

[Click to download full resolution via product page](#)

Figure 1: Mechanistic origin of common impurities in methoxy-indanone synthesis.

Troubleshooting Recrystallization (Scalable Solution)

Recrystallization is the preferred method for this scaffold, but methoxy-indanones are notorious for "oiling out" (forming a second liquid phase rather than crystals) due to their low melting points and high solubility in organic solvents.[1]

Issue: "The product oils out upon cooling."

Cause: The solution is too concentrated, or the solvent boiling point is higher than the product's melting point (MP). **Solution:** Switch to a High-Polarity/Low-Solubility solvent system.[1]

Recommended Protocol: The Methanol/Water Gradient

Methanol (MeOH) is often superior to Toluene/Heptane for methoxy-substituted indanones because it solubilizes the polar phenolic impurities (Impurity A) while forcing the target indanone to crystallize.[1]

- **Dissolution:** Dissolve crude solid in the minimum amount of boiling MeOH.

- Note: If insoluble black specs remain, filter hot through a Celite pad.
- Saturation: Remove from heat. Add water dropwise until a persistent turbidity (cloudiness) just appears.
- Clarification: Add 1-2 drops of hot MeOH to clear the solution.
- Slow Cooling: Wrap the flask in foil/towel to cool slowly to room temperature (RT).
 - Critical: Do not place directly in an ice bath; this causes oiling.
- Crystallization: Once solid crystals form at RT, move to

for 2 hours.

Data Comparison: Solvent Systems

Solvent System	Yield Potential	Purity Potential	Risk Factor
MeOH /	85-90%	High (>99%)	Low (Prevents oiling if water added slowly)
Toluene / Heptane	70-80%	Moderate (97%)	High (Oiling out is common)
Ethanol (Abs)	60-70%	High (>99%)	Moderate (Solubility often too high)

Chromatographic Resolution (Precision Solution)

If recrystallization fails (e.g., purity <95%), column chromatography is required.^[1] The 7-methoxy group adds polarity, making this compound stickier than unsubstituted indanones.^[1]

Issue: "The product co-elutes with the starting material."

Cause: Inappropriate stationary phase interaction or solvent strength. Solution: Use a gradient elution on Silica Gel 60 (

mesh).^[1]

Validated Chromatography Protocol

- Stationary Phase: Silica Gel ([1](#))
- Loading: Dry load (adsorb crude onto silica) is recommended over wet loading to prevent band tailing. [1](#)
- Mobile Phase Gradient:
 - Start: 100% Hexane (2 Column Volumes - CV) to flush non-polar hydrocarbons. [1](#)
 - Ramp: 0%
15% Ethyl Acetate (EtOAc) in Hexane over 10 CV.
 - Elution: Target compound typically elutes between 10-15% EtOAc. [1](#)
 - Flush: 50% EtOAc to remove polar phenolic impurities (Impurity A).

TLC Visualization:

- UV (254 nm): Strong absorption due to the conjugated ketone.
- Stain: 2,4-DNP (Dinitrophenylhydrazine) stain is specific for ketones (turns orange/red). [1](#)

Decision Tree: Purification Logic

Use this logic flow to determine the immediate next step for your specific batch.

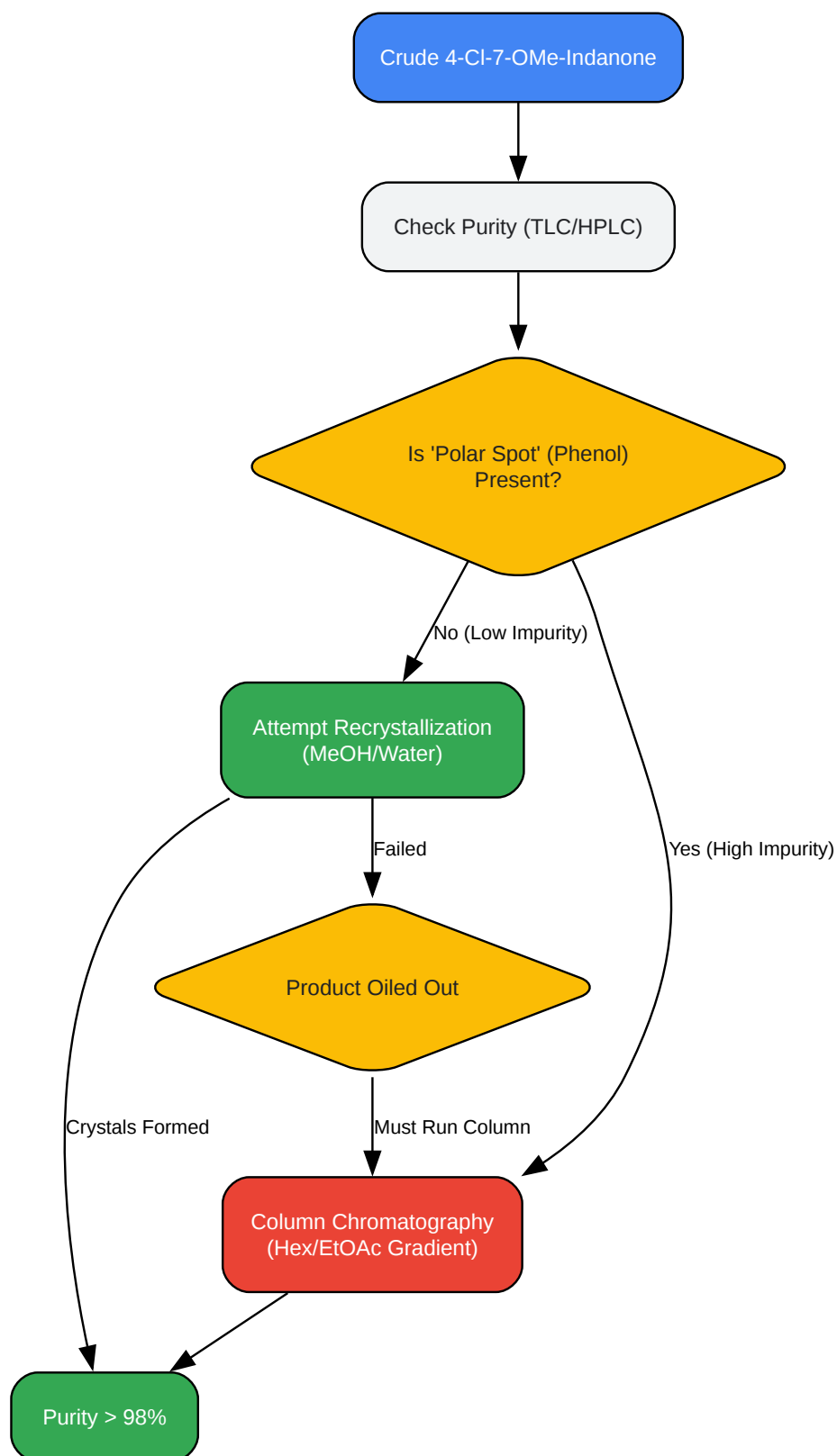

[Click to download full resolution via product page](#)

Figure 2: Strategic decision tree for selecting the purification method.

Frequently Asked Questions (FAQ)

Q1: My product turned dark brown after sitting on the bench for 2 days. Is it ruined? A: Not necessarily. Indanones, especially electron-rich ones (methoxy-substituted), are prone to surface oxidation.^[1]

- Fix: Wash the solid with cold hexanes. The dark oxidation products are usually on the surface. If that fails, perform a quick filtration through a short plug of silica (eluting with 10% EtOAc/Hexane). Store future batches under Nitrogen/Argon at

Q2: I see a new spot on TLC after using

. What is it? A: This is almost certainly 4-chloro-7-hydroxy-1-indanone.^[1] The methoxy ether cleavage is a classic side reaction of Friedel-Crafts conditions when

is used in stoichiometric excess or at reflux temperatures.^[1]

- Prevention:^[1] Keep reaction temperature

during addition and do not exceed RT for the reaction duration. Consider using milder Lewis acids like

if the problem persists.

Q3: Can I use vacuum distillation for purification? A: Not recommended. Substituted indanones have high boiling points and are thermally unstable. Prolonged heating required for distillation often leads to dechlorination or polymerization. Sublimation under high vacuum is a safer alternative for small (<1g) scales.

References

- Beilstein Journals. (2017). Synthesis of 1-indanones with a broad range of biological activity. Retrieved from [\[Link\]](#)^[1]
- PrepChem. Synthesis of 4-Methoxy-1-indanone. Retrieved from [\[Link\]](#)^[1]

- ScienceMadness. (2023). Contaminated 1-indanone sample - Troubleshooting Guide. Retrieved from [[Link](#)][1]

Need Custom Synthesis?

BenchChem offers custom synthesis for rare earth carbides and specific isotopic labeling.

Email: info@benchchem.com or [Request Quote Online](#).

Sources

- 1. CN110386936B - Preparation method of 4-chloro-7H-pyrrolo [2,3-d] pyrimidine - Google Patents [patents.google.com]
- To cite this document: BenchChem. [resolving 4-Chloro-7-methoxy-1-indanone purification issues]. BenchChem, [2026]. [Online PDF]. Available at: [<https://www.benchchem.com/product/b1316982/docs#resolving-4-chloro-7-methoxy-1-indanone-purification-issues>]

Disclaimer & Data Validity:

The information provided in this document is for Research Use Only (RUO) and is strictly not intended for diagnostic or therapeutic procedures. While BenchChem strives to provide accurate protocols, we make no warranties, express or implied, regarding the fitness of this product for every specific experimental setup.

Technical Support: The protocols provided are for reference purposes. Unsure if this reagent suits your experiment?

Need Industrial/Bulk Grade? [Request Custom Synthesis Quote](#)

BenchChem

Our mission is to be the trusted global source of essential and advanced chemicals, empowering scientists and researchers to drive progress in science and industry.

Contact

Address: 3281 E Guasti Rd

Ontario, CA 91761, United States

Phone: (601) 213-4426

Email: info@benchchem.com

[Contact our Ph.D. Support Team for a compatibility check](#)