

Spectroscopic Profiling of 2-Chloro-N-Propylaniline: A Comparative IR Analysis Guide

Author: BenchChem Technical Support Team. **Date:** May 2026

Compound of Interest

Compound Name: 2-chloro-N-propylaniline

CAS No.: 55238-18-1

Cat. No.: B1316725

[Get Quote](#)

Executive Summary & Objective

This guide provides a definitive infrared (IR) spectroscopic profile for **2-chloro-N-propylaniline** (CAS: 10264-26-3).[1] In drug development and organic synthesis, this secondary amine often serves as a critical intermediate.[1] The primary challenge in its characterization is distinguishing it from:

- The Precursor: 2-Chloroaniline (Primary amine).[1]
- Positional Isomers: 4-Chloro-N-propylaniline (Para-substituted).[1]

This document moves beyond basic peak listing. It establishes a comparative identification logic to validate reaction completion (N-alkylation) and isomeric purity using ATR-FTIR (Attenuated Total Reflectance Fourier Transform Infrared Spectroscopy).

Theoretical Framework: Vibrational Logic

Understanding the spectrum requires deconstructing the molecule into its vibrational components. The spectrum is a superposition of the ortho-substituted chloro-benzene ring and

the N-propyl secondary amine tail.

Vibrational Pathway Diagram

The following logic flow illustrates how structural features translate to specific detector signals.

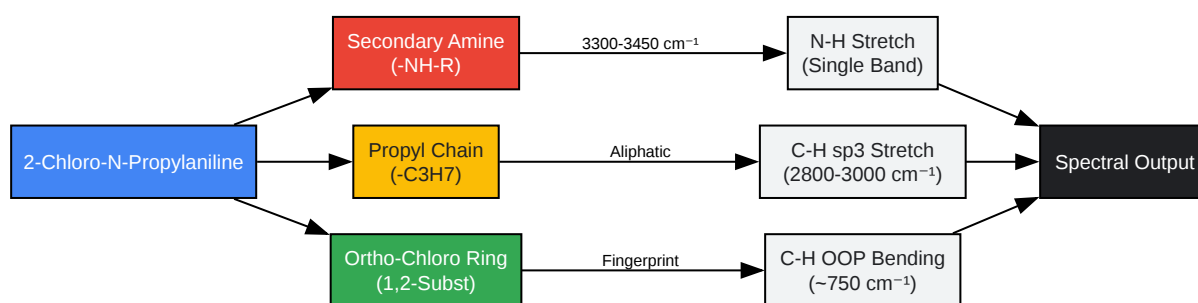

[Click to download full resolution via product page](#)

Figure 1: Vibrational logic flow connecting molecular substructures to specific IR detection zones.

Comparative Characteristic Band Analysis

This section provides the core data for identification.^[1] The values below are "Characteristic Reference Values" derived from standard spectroscopic data for aniline derivatives.

Comparison 1: Monitoring Reaction Progress (Target vs. Precursor)

The most common application is monitoring the reductive amination of 2-chloroaniline.^[1] The key indicator is the transformation of the amine group.

Feature	Precursor: 2-Chloroaniline	Target: 2-Chloro-N-Propylaniline	Diagnostic Significance
Amine Type	Primary (-NH ₂)	Secondary (-NH-R)	CRITICAL
N-H Stretch	Doublet (Sym & Asym)~3480 & 3390 cm ⁻¹	Singlet (Weak)~3400 cm ⁻¹	Disappearance of the doublet confirms mono-alkylation.[1]
N-H Bend	Strong Scissoring~1620 cm ⁻¹	Absent / Very Weak	Secondary amines lack the strong scissoring mode.
C-H Stretch	Aromatic only (>3000 cm ⁻¹)	Aromatic + Aliphatic	Appearance of sp ³ C-H bands (2850-2960 cm ⁻¹) confirms propyl chain attachment.[1]

Comparison 2: Isomeric Purity (Ortho vs. Para)

In synthesis, regio-selectivity is paramount.[1] Distinguishing the ortho (2-chloro) product from a potential para (4-chloro) impurity relies on the "Fingerprint Region" (600–1500 cm⁻¹).[1]

Feature	Target (Ortho)	Isomer (Para)	Mechanism
C-H OOP Bend	~735–770 cm ⁻¹ (Strong)	~800–850 cm ⁻¹ (Strong)	Out-of-plane (OOP) bending of adjacent aromatic hydrogens. [1]
Overtone Pattern	4 small peaks (1600-2000 cm ⁻¹)	2 small peaks (1600-2000 cm ⁻¹)	"Benzene Fingers" region; requires high concentration/pathlength to see.[1]

Detailed Band Assignment Table

Use this table for peak assignment in your final report.

Wavenumber (cm ⁻¹)	Intensity	Assignment	Notes
3380 – 3420	Weak/Broad	N-H Stretch	Characteristic of secondary amines.[1] [2] May be obscured if sample is wet (OH overlap).[1]
3030 – 3070	Weak	C-H Stretch (sp ²)	Aromatic ring hydrogens.
2950 – 2970	Medium	C-H Stretch (sp ³)	Asymmetric stretch of Methyl (-CH ₃) group on propyl chain.[1]
2860 – 2880	Medium	C-H Stretch (sp ³)	Symmetric stretch of Methylene (-CH ₂ -) groups.[1]
1580 – 1600	Medium/Strong	C=C Ring Stretch	Aromatic skeletal vibration.
1250 – 1340	Strong	C-N Stretch (Ar-N)	Aryl-Amine bond.[1] Stronger than aliphatic C-N due to resonance.[1]
1050 – 1080	Medium	C-Cl Stretch	Aryl-Chloride (In-plane).[1] Note: Often difficult to assign definitively.[1]
740 – 760	Very Strong	C-H OOP Bend	Diagnostic: 1,2-disubstitution (Ortho). [1] Indicates 4 adjacent aromatic protons.[1]

Experimental Protocol: ATR-FTIR Acquisition

Methodology: Attenuated Total Reflectance (ATR) is superior to KBr pellets for this compound, as N-alkyl anilines are often oils or low-melting solids that are difficult to dry completely.[1]

Workflow Diagram

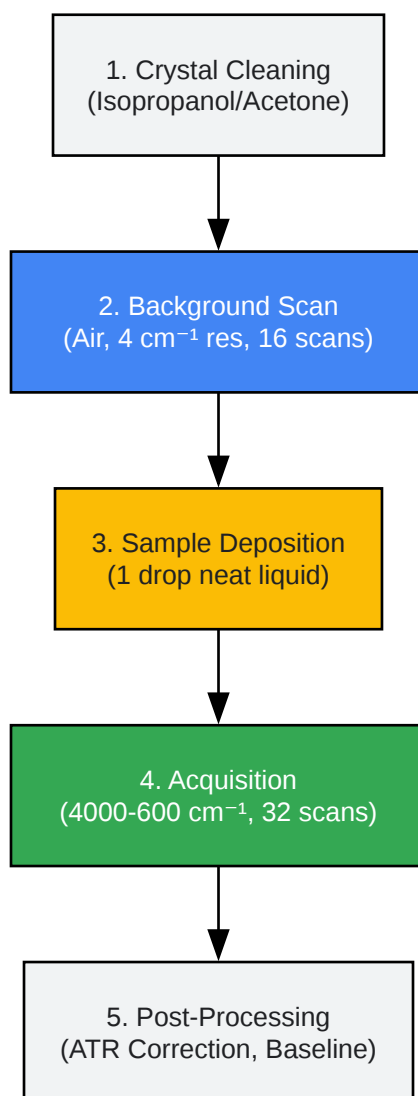

[Click to download full resolution via product page](#)

Figure 2: Standard Operating Procedure for ATR-FTIR analysis of liquid amines.

Step-by-Step Procedure

- Crystal Prep: Clean the ZnSe or Diamond ATR crystal with isopropanol.[1] Ensure no residue remains from previous runs.[1]

- Background: Collect a background spectrum of ambient air to subtract CO₂ (2350 cm⁻¹) and H₂O vapor.[1]
- Sample Loading:
 - If Liquid: Place one drop of **2-chloro-N-propylaniline** directly on the crystal.[1]
 - If Solid: Place a small amount on the crystal and apply pressure using the anvil clamp to ensure intimate contact.
- Parameters:
 - Range: 4000 – 600 cm⁻¹[1]
 - Resolution: 4 cm⁻¹[1]
 - Scans: 32 (Routine) or 64 (High S/N)[1]
- Cleaning: Immediately clean the crystal after scanning.[1] Anilines can oxidize and stain ZnSe crystals.[1]

Troubleshooting & Artifacts

- Broad Peak at 3400 cm⁻¹: If the N-H peak is incredibly broad and strong, your sample likely contains moisture (H₂O).[1] Dry the sample over MgSO₄ or molecular sieves.[1]
- Doublet at 2350 cm⁻¹: This is atmospheric CO₂. [1] It indicates the background scan was not recent enough or the purge is failing. It does not interfere with the fingerprint region.[1]
- Missing C-Cl Peak: The C-Cl stretch (aryl) is often mixed with ring vibrations.[1] Do not rely solely on the 1000-1100 cm⁻¹ region for confirmation; use the Ortho OOP bend (740-760 cm⁻¹) as the primary confirmation of the chlorine position.[1]

References

- Silverstein, R. M., Webster, F. X., & Kiemle, D. J. (2005). Spectrometric Identification of Organic Compounds (7th ed.). John Wiley & Sons.[1][3] (Authoritative text for N-H and C-H band assignments).

- NIST Mass Spectrometry Data Center. (n.d.).^[1] IR Spectrum of 4-Chloroaniline. NIST Chemistry WebBook, SRD 69.^[1] Retrieved from [[Link](#)] (Used for comparative "Para" substitution data).^[1]
- SDBS. (n.d.). Spectral Database for Organic Compounds, SDBS.^[1] National Institute of Advanced Industrial Science and Technology (AIST).^[1] (General reference for Aniline and N-propylaniline base spectra).
- Socrates, G. (2001).^[1] Infrared and Raman Characteristic Group Frequencies: Tables and Charts (3rd ed.). Wiley.^[1]^[3] (Source for specific Ortho-substitution OOP bending ranges).

Need Custom Synthesis?

BenchChem offers custom synthesis for rare earth carbides and specific isotopic labeling.

Email: info@benchchem.com or [Request Quote Online](#).

Sources

- 1. uomustansiriyah.edu.iq [uomustansiriyah.edu.iq]
- 2. spcm.ac.in [spcm.ac.in]
- 3. spectrabase.com [spectrabase.com]
- To cite this document: BenchChem. [Spectroscopic Profiling of 2-Chloro-N-Propylaniline: A Comparative IR Analysis Guide]. BenchChem, [2026]. [Online PDF]. Available at: [<https://www.benchchem.com/product/b1316725/docs#spectroscopic-profiling-of-2-chloro-n-propylaniline-a-comparative-ir-analysis-guide>]

Disclaimer & Data Validity:

The information provided in this document is for Research Use Only (RUO) and is strictly not intended for diagnostic or therapeutic procedures. While BenchChem strives to provide accurate protocols, we make no warranties, express or implied, regarding the fitness of this product for every specific experimental setup.

Technical Support: The protocols provided are for reference purposes. Unsure if this reagent suits your experiment?

Need Industrial/Bulk Grade? [Request Custom Synthesis Quote](#)

BenchChem

Our mission is to be the trusted global source of essential and advanced chemicals, empowering scientists and researchers to drive progress in science and industry.

Contact

Address: 3281 E Guasti Rd
Ontario, CA 91761, United States
Phone: (601) 213-4426
Email: info@benchchem.com

[Contact our Ph.D. Support Team for a compatibility check](#)