

The Strained Ring: A Technical and Historical Guide to Cyclobutane-Containing Compounds

Author: BenchChem Technical Support Team. **Date:** April 2026

Compound of Interest

Compound Name: *2-(4-Methoxyphenyl)cyclobutan-1-amine*

Cat. No.: *B13158886*

[Get Quote](#)

Abstract

The cyclobutane ring, a four-membered carbocycle, has traversed a remarkable journey from a theoretical curiosity born of strain theory to a highly valued structural motif in modern chemistry. Its inherent ring strain, once viewed as a sign of instability, is now harnessed as a source of unique reactivity and a tool for precise conformational control. This guide provides an in-depth exploration of the discovery, history, and evolving synthetic strategies for cyclobutane-containing compounds. We will examine the foundational theories that first described its properties, chronicle the landmark synthetic achievements, detail modern synthetic protocols, and survey its critical applications in the fields of natural product synthesis, drug discovery, and materials science. This document is intended for researchers, scientists, and drug development professionals seeking a comprehensive understanding of this fascinating and synthetically powerful chemical entity.

The Genesis of a Strained Ring: Theory and Early Discovery

The story of cyclobutane is intrinsically linked to the concept of ring strain. In the late 19th century, as chemists began to explore cyclic structures, the stability of these new molecules was a subject of intense debate.

Baeyer's Strain Theory: A Foundational, Flawed Perspective

In 1885, Adolf von Baeyer proposed the first coherent theory to explain the stability of cycloalkanes.[1][2] His theory was predicated on a simple, elegant, yet ultimately incomplete assumption: that all cycloalkanes are planar polygons. Baeyer postulated that any deviation from the ideal tetrahedral bond angle of 109.5° would induce a state of "angle strain," destabilizing the molecule. According to this model, a planar cyclobutane with 90° internal angles would be significantly strained and therefore less stable than cyclopentane, which has internal angles of 108° in a planar pentagon.[1][3]

While Baeyer's theory correctly identified angle strain as a key destabilizing factor for small rings like cyclopropane and cyclobutane, its assumption of planarity was a critical limitation. It failed to account for torsional strain (eclipsing interactions between adjacent C-H bonds) and incorrectly predicted that larger rings would be increasingly strained.[3]

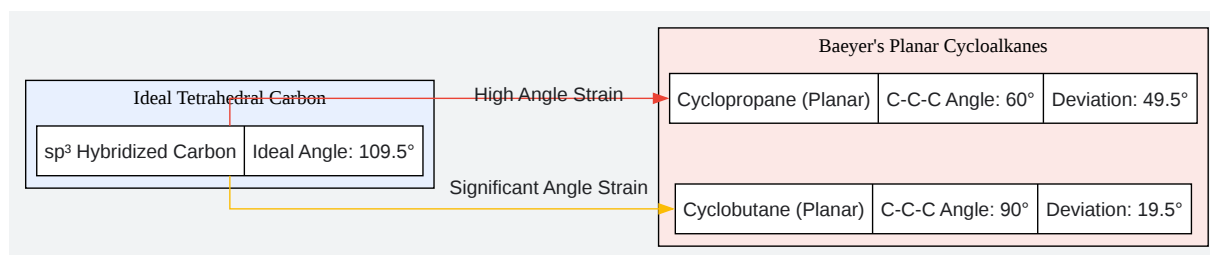

[Click to download full resolution via product page](#)

Caption: Baeyer's Strain Theory illustrating angle deviation from the ideal 109.5° .

Beyond Planarity: The Modern View of Cyclobutane's Structure

Modern structural analysis has revealed that cyclobutane is not planar. To relieve the torsional strain that would arise from eight eclipsing C-H bonds in a flat structure, the ring adopts a

puckered or "butterfly" conformation.^{[3][4][5][6]} In this conformation, one carbon atom is bent out of the plane of the other three by about 25°.^{[3][6]} This puckering slightly increases the angle strain (compressing the C-C-C angles to ~88°) but significantly reduces the torsional strain, resulting in a more stable overall structure.^{[3][5]} The molecule rapidly interconverts between equivalent puckered conformations in solution.^[4]

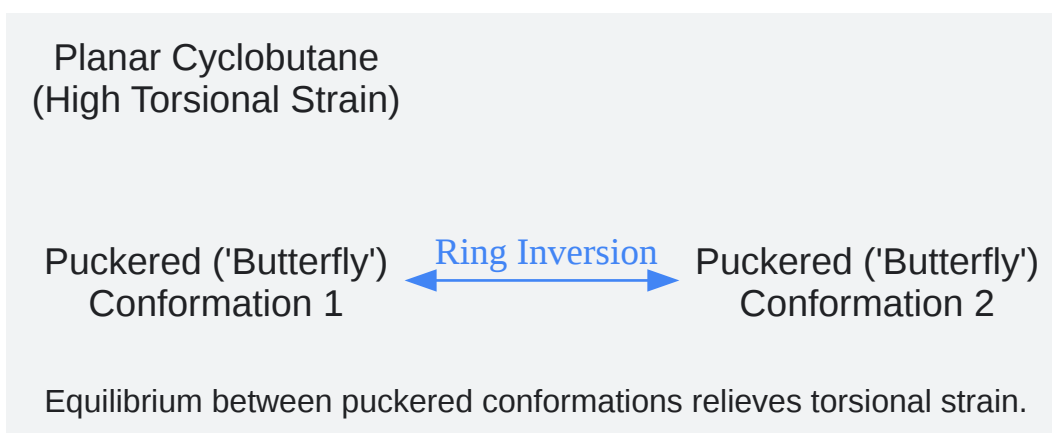

[Click to download full resolution via product page](#)

Caption: Cyclobutane puckering to relieve torsional strain.

This combination of angle and torsional strain gives cyclobutane a total ring strain energy of approximately 26.3 kcal/mol, making it significantly more reactive than its larger cycloalkane counterparts like cyclopentane and cyclohexane.^{[4][7][8]}

Cycloalkane	Ring Strain (kcal/mol)	C-C-C Bond Angle	Key Strain Contributor(s)
Cyclopropane	27.6	60°	Angle, Torsional
Cyclobutane	26.3	~88° (puckered)	Angle, Torsional
Cyclopentane	7.1	~105° (envelope)	Torsional
Cyclohexane	0	109.5° (chair)	(Essentially Strain-Free)

Table 1: Comparison of Ring Strain in Small Cycloalkanes.^{[4][7][8]}

The First Synthesis: Willstätter's Landmark Achievement

Despite the theoretical challenges, the existence of the cyclobutane ring was first proven experimentally by William Perkin, Jr. in the 1880s through the synthesis of derivatives.[9] However, the parent hydrocarbon, cyclobutane, remained elusive until 1907. Richard Willstätter and James Bruce achieved its first synthesis by hydrogenating cyclobutene over a nickel catalyst.[10] This followed the even more challenging synthesis of cyclobutene itself by Willstätter and Wolfgang von Schmaedel in 1905, accomplished via a multi-step sequence culminating in a Hofmann elimination.[9]

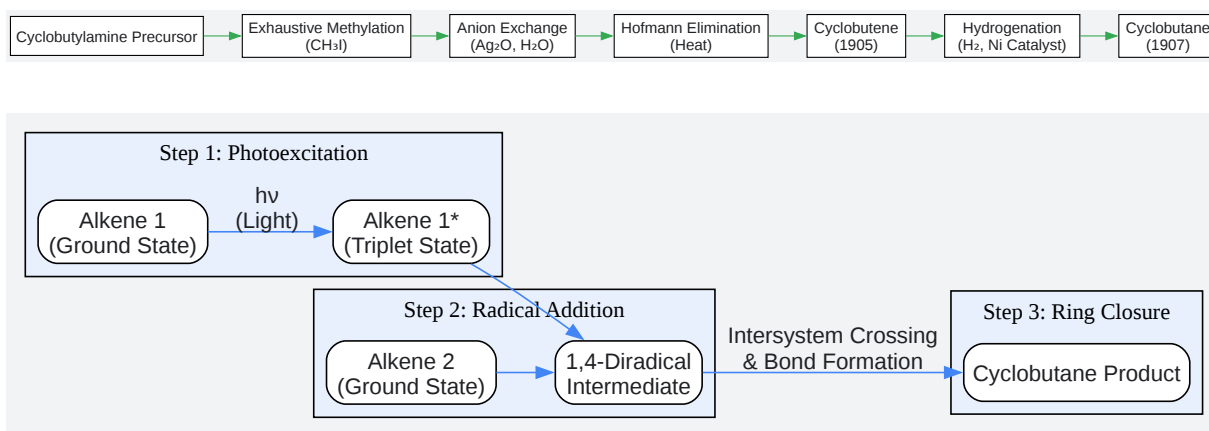

[Click to download full resolution via product page](#)

Caption: General mechanism for a photosensitized [2+2] cycloaddition.

Experimental Protocol: Generalized Photochemical [2+2] Enone Cycloaddition

This protocol describes a representative, self-validating system for the synthesis of a cyclobutane ring via photochemical cycloaddition, a cornerstone of the field.

- **System Preparation:** A quartz reaction vessel equipped with a magnetic stir bar, a reflux condenser, and a nitrogen inlet is charged with the enone substrate (1.0 eq) and the alkene partner (3-10 eq). The use of a quartz vessel is critical as standard borosilicate glass (Pyrex) will absorb the low-wavelength UV light required for excitation.
- **Solvent and Sensitizer:** The reactants are dissolved in an appropriate solvent (e.g., acetone, acetonitrile, or benzene). Acetone often serves as both the solvent and a triplet sensitizer. If

a different solvent is used, a sensitizer like benzophenone (0.1-0.3 eq) may be added to facilitate the efficient population of the enone's triplet state. The solution is deoxygenated by bubbling nitrogen through it for 15-30 minutes, as dissolved oxygen can quench the excited triplet state.

- **Irradiation:** The vessel is placed in a photochemical reactor and irradiated with a medium- or high-pressure mercury lamp. The reaction is typically cooled using a water jacket or immersion well to prevent thermal side reactions.
- **Monitoring and Validation:** The reaction progress is monitored by Thin Layer Chromatography (TLC) or Gas Chromatography (GC) by periodically taking aliquots. The disappearance of the limiting reagent (enone) indicates completion. A successful reaction is validated by the appearance of a new spot(s) on the TLC plate corresponding to the cyclobutane product(s).
- **Workup and Purification:** Upon completion, the solvent is removed under reduced pressure. The crude residue is then purified by flash column chromatography on silica gel to isolate the cyclobutane adduct(s). The stereochemistry of the product is determined by NMR spectroscopy, often relying on Nuclear Overhauser Effect (NOE) experiments.

2.1.2 Thermal and Metal-Catalyzed [2+2] Cycloadditions

While photochemistry is dominant, thermal [2+2] cycloadditions are possible with activated substrates, such as highly electrophilic fluorinated alkenes or strained alkenes. [11] Additionally, transition metal catalysis has emerged as a powerful alternative, enabling cycloadditions that are otherwise difficult or impossible. [12][13] These methods can offer different selectivity profiles and milder reaction conditions compared to photochemical approaches.

Alternative Synthetic Strategies

Beyond cycloadditions, other clever strategies have been developed to access the cyclobutane core. These include:

- **Ring-Contraction Reactions:** Methods like the Wolff rearrangement of α -diazocyclopentanones can contract a five-membered ring to a four-membered one. [14]*
- **Intramolecular Cyclizations:** 1,4-dihalobutanes can be converted to cyclobutanes via dehalogenation with a reducing metal. [10] More modern approaches utilize radical or polar

cyclizations. [15][16]* C–H Functionalization Logic: In a paradigm shift from traditional cycloadditions, researchers like Baran have demonstrated the synthesis of complex cyclobutane natural products by building the ring first and then using modern C-H activation techniques to install functionality. [14]

The Cyclobutane Motif in Nature and Medicine

The unique structural and chemical properties of the cyclobutane ring have made it a recurring feature in natural products and a valuable building block in medicinal chemistry.

Cyclobutanes in Natural Products

Although less common than five- or six-membered rings, the cyclobutane motif is found in a diverse array of natural products isolated from plants, fungi, and marine organisms. [7][17][18] These compounds often exhibit potent biological activities. [19][20]

- Scepterin: An antimicrobial agent isolated from the marine sponge *Agelas scepterum*, featuring a dimeric cyclobutane structure. [7][18]* Pentacycloanammoxic Acid: A remarkable "ladderane" lipid found in bacteria that perform anaerobic ammonium oxidation (anammox). It consists of five fused cyclobutane rings, forming an exceptionally dense membrane to protect the organism from toxic intermediates. [10]* Piperarborenines: A family of natural products isolated from *Piper* species, some of which feature a head-to-head cyclobutane dimer structure. [14]* Cyclobutane Pyrimidine Dimers (CPDs): Not a natural product in the traditional sense, but a biologically significant structure formed when UV radiation causes a [2+2] cycloaddition between adjacent pyrimidine bases in DNA, leading to DNA damage. [7][10][17]

Applications in Drug Discovery and Development

Medicinal chemists are increasingly incorporating the cyclobutane ring into drug candidates to modulate their pharmacological properties. [7] As of January 2021, at least 39 preclinical or clinical drug candidates contained a cyclobutane ring. [7] Its utility stems from several key characteristics:

- Conformational Restriction: The rigid, puckered structure of the cyclobutane ring can lock a molecule into a specific bioactive conformation, improving its binding affinity to a target protein. [7][17]* Metabolic Stability: It can be used to replace metabolically vulnerable

groups, such as alkenes or larger rings, thereby increasing the drug's half-life. [7]* Improved Physicochemical Properties: As a non-planar, saturated scaffold, it can reduce the planarity of a molecule compared to an aromatic ring, which can enhance water solubility and other ADMET (absorption, distribution, metabolism, excretion, and toxicity) properties. [12]* Bioisostere: It can serve as a three-dimensional bioisostere for other chemical groups, such as phenyl rings or gem-dimethyl groups, providing a novel way to explore chemical space and fill hydrophobic pockets in protein binding sites. [7] A prominent example of a cyclobutane-containing drug is Carboplatin, a platinum-based chemotherapy agent used to treat various cancers. [7][17] The cyclobutanedicarboxylate ligand in Carboplatin modulates the reactivity of the platinum center compared to its predecessor, Cisplatin, resulting in a different toxicity profile.

Conclusion and Future Outlook

From its theoretical conception as a highly strained, unstable entity to its current status as a sophisticated tool in the chemist's arsenal, the cyclobutane ring has proven to be a molecule of immense scientific interest and practical utility. The initial hurdles of its synthesis, first overcome by the landmark work of Willstätter, have given way to a plethora of reliable and stereoselective methods, dominated by the versatile [2+2] cycloaddition. The unique conformational and electronic properties imparted by its ring strain are no longer seen as liabilities but as assets, enabling the design of conformationally locked pharmaceuticals and the synthesis of complex natural products. As synthetic

methods continue to advance, particularly in areas like transition-metal catalysis and C-H functionalization, the accessibility and application of cyclobutane-containing compounds in drug discovery, materials science, and beyond are set to expand even further. [24]

References

- Blanco-Ania, D., van der Kolk, R., & Rutjes, F. P. J. T. (2021). Cyclobutanes in Small-Molecule Drug Candidates. *ChemMedChem*, 17(1).
- Organic Chemistry Portal. (n.d.). Synthesis of cyclobutanes.
- Auburn University. (2023). Synthesis of Cyclobutane-Containing Natural Products using Macrocyclic 1,4- Diketones as Templates for Diastereoselective Transformations.
- Hou, S. Y., Yan, B. C., Sun, H. D., & Puno, P. T. (2024). Recent advances in the application of [2 + 2] cycloaddition in the chemical synthesis of cyclobutane-containing natural products. *Natural Products and Bioprospecting*, 14(5), 37.
- Baran Lab. (n.d.). Synthesis of Cyclobutane Natural Products using C–H Functionalization Logic.
- BenchChem. (2025). The Dawn of a Strained Ring: A Historical and Technical Perspective on the Discovery of Cyclobutene.
- Master Organic Chemistry. (2014). Cycloalkanes - Ring Strain In Cyclopropane And Cyclobutane.
- Royal Society of Chemistry. (2020). Recent advances in the total synthesis of cyclobutane-containing natural products. *Organic Chemistry Frontiers*.
- Radboud Repository. (n.d.). Cyclobutanes in Small-Molecule Drug Candidates.
- Wikipedia. (n.d.). Cyclobutane.
- Sergeiko, A., Poroikov, V. V., & Hanuš, L. O. (2008). Cyclobutane-Containing Alkaloids: Origin, Synthesis, and Biological Activities. *The Natural Products Journal*, 1(1).
- Natural Products and Bioprospecting. (2024). Recent advances in the application of [2+2] cycloaddition in the chemical synthesis of cyclobutane-containing natural products.
- Bentham Science. (2008). Cyclobutane-Containing Alkaloids: Origin, Synthesis, and Biological Activities.
- ResearchGate. (n.d.). The application of cyclobutane derivatives in organic synthesis.
- Life Chemicals. (2020). Explore Our Novel Cyclobutane Derivatives.
- Chemistry LibreTexts. (2024). 4.4: Conformations of Cycloalkanes.

- Fasano, V., & Aggarwal, V. K. (2025). Diastereoselective Synthesis of Cyclobutanes via Rh-Catalyzed Unprecedented C–C Bond Cleavage of Alkylidenecyclopropanes. *Organic Letters*.
- Chemistry LibreTexts. (2024). 4.3: Stability of Cycloalkanes - Ring Strain.
- Bach, T. (2016). Recent Advances in the Synthesis of Cyclobutanes by Olefin [2 + 2] Photocycloaddition Reactions. *Chemical Reviews*, 116(17), 9882-9911.
- Dalal Institute. (n.d.). Conformational Analysis of Cycloalkanes (Upto Six Membered Rings).
- Bennett, S. H., Fawcett, A., & Aggarwal, V. K. (2020). Photoredox-Catalyzed Cyclobutane Synthesis by a Deboronative Radical Addition–Polar Cyclization Cascade. *Angewandte Chemie International Edition*, 59(38), 16766-16775.
- POC II Unit V: Cycloalkane. (n.d.).
- BenchChem. (2025). [2+2] Cycloaddition for Cyclobutane Ring Formation.
- Lumen Learning. (n.d.). Conformers of Cycloalkanes.
- Vedantu. (2024). The angle strain in cyclobutane.
- Master Organic Chemistry. (2014). Calculation of Ring Strain In Cycloalkanes.

Need Custom Synthesis?

BenchChem offers custom synthesis for rare earth carbides and specific isotopic labeling.

Email: info@benchchem.com or [Request Quote Online](#).

Sources

- [1. chem.libretexts.org \[chem.libretexts.org\]](https://chem.libretexts.org)
- [2. The angle strain in cyclobutane is a 2944 b 2916 c class 12 chemistry CBSE \[vedantu.com\]](https://vedantu.com)
- [3. Conformers of Cycloalkanes | MCC Organic Chemistry \[courses.lumenlearning.com\]](https://courses.lumenlearning.com)
- [4. masterorganicchemistry.com \[masterorganicchemistry.com\]](https://masterorganicchemistry.com)
- [5. chem.libretexts.org \[chem.libretexts.org\]](https://chem.libretexts.org)
- [6. dalalinstitute.com \[dalalinstitute.com\]](https://dalalinstitute.com)
- [7. Cyclobutanes in Small-Molecule Drug Candidates - PMC \[pmc.ncbi.nlm.nih.gov\]](https://pmc.ncbi.nlm.nih.gov)
- [8. masterorganicchemistry.com \[masterorganicchemistry.com\]](https://masterorganicchemistry.com)
- [9. pdf.benchchem.com \[pdf.benchchem.com\]](https://pdf.benchchem.com)
- [10. Cyclobutane - Wikipedia \[en.wikipedia.org\]](https://en.wikipedia.org)

- [11. pdf.benchchem.com \[pdf.benchchem.com\]](https://pdf.benchchem.com)
- [12. pubs.acs.org \[pubs.acs.org\]](https://pubs.acs.org)
- [13. Cyclobutane synthesis \[organic-chemistry.org\]](https://organic-chemistry.org)
- [14. baranlab.org \[baranlab.org\]](https://baranlab.org)
- [15. Recent advances in the application of \[2 + 2\] cycloaddition in the chemical synthesis of cyclobutane-containing natural products - PMC \[pmc.ncbi.nlm.nih.gov\]](https://pmc.ncbi.nlm.nih.gov)
- [16. Photoredox-Catalyzed Cyclobutane Synthesis by a Deboronative Radical Addition–Polar Cyclization Cascade - PMC \[pmc.ncbi.nlm.nih.gov\]](https://pmc.ncbi.nlm.nih.gov)
- [17. repository.ubn.ru.nl \[repository.ubn.ru.nl\]](https://repository.ubn.ru.nl)
- [18. Cyclobutane-Containing Alkaloids: Origin, Synthesis, and Biological Activities - PMC \[pmc.ncbi.nlm.nih.gov\]](https://pmc.ncbi.nlm.nih.gov)
- [19. Recent advances in the total synthesis of cyclobutane-containing natural products - Organic Chemistry Frontiers \(RSC Publishing\) \[pubs.rsc.org\]](https://pubs.rsc.org)
- [20. Cyclobutane-Containing Alkaloids: Origin, Synthesis, and Biological Activities \[openmedicinalchemistryjournal.com\]](https://openmedicinalchemistryjournal.com)
- To cite this document: BenchChem. [The Strained Ring: A Technical and Historical Guide to Cyclobutane-Containing Compounds]. BenchChem, [2026]. [Online PDF]. Available at: [\[https://www.benchchem.com/product/b13158886/docs#the-strained-ring-a-technical-and-historical-guide-to-cyclobutane-containing-compounds\]](https://www.benchchem.com/product/b13158886/docs#the-strained-ring-a-technical-and-historical-guide-to-cyclobutane-containing-compounds)

Disclaimer & Data Validity:

The information provided in this document is for Research Use Only (RUO) and is strictly not intended for diagnostic or therapeutic procedures. While BenchChem strives to provide accurate protocols, we make no warranties, express or implied, regarding the fitness of this product for every specific experimental setup.

Technical Support: The protocols provided are for reference purposes. Unsure if this reagent suits your experiment?

Need Industrial/Bulk Grade? [Request Custom Synthesis Quote](#)

BenchChem

Our mission is to be the trusted global source of essential and advanced chemicals, empowering scientists and researchers to drive progress in science and industry.

Contact

Address: 3281 E Guasti Rd

Ontario, CA 91761, United States

Phone: (601) 213-4426

Email: info@benchchem.com

[Contact our Ph.D. Support Team for a compatibility check](#)