

Technical Support Center: Improving Regioselectivity in Pyridine Functionalization

Author: BenchChem Technical Support Team. **Date:** May 2026

Compound of Interest

Compound Name: 2-Amino-6-benzyloxy pyridine

CAS No.: 1174626-28-8

Cat. No.: B581361

[Get Quote](#)

This technical support center provides troubleshooting guides and frequently asked questions (FAQs) for researchers, scientists, and drug development professionals working on the regioselective functionalization of pyridine. The content is designed to address specific experimental challenges and offer practical solutions.

Frequently Asked Questions (FAQs)

Q1: Why is achieving regioselectivity in pyridine functionalization so challenging?

A1: The regioselectivity of pyridine functionalization is dictated by the electronic properties of the pyridine ring. The nitrogen atom is electron-withdrawing, making the entire ring electron-deficient and less reactive towards electrophiles compared to benzene. This electron deficiency is most pronounced at the C2 (ortho) and C4 (para) positions, making them susceptible to nucleophilic attack. Conversely, the C3 (meta) position is the most electron-rich and thus the preferred site for electrophilic substitution, although the overall reactivity is low. The nitrogen atom's lone pair can also coordinate with metal catalysts, which can complicate catalytic reactions and sometimes lead to catalyst poisoning.^{[1][2]}

Q2: What are the general strategies to control the regioselectivity of pyridine functionalization?

A2: Several strategies have been developed to control the site of functionalization on the pyridine ring:

- **Electronic Control:** Exploiting the inherent electronic properties of the pyridine ring, where nucleophiles tend to attack the C2/C4 positions and electrophiles the C3 position.
- **Steric Hindrance:** Introducing bulky groups on the pyridine ring or the attacking reagent can block certain positions and direct functionalization to less hindered sites.
- **Directing Groups:** Attaching a directing group to the pyridine ring can force the reaction to occur at a specific position, often through the formation of a stable cyclic intermediate with the catalyst.
- **Temporary Dearomatization:** The pyridine ring can be temporarily dearomatized to an electron-rich intermediate, which then reacts with electrophiles at specific positions. Subsequent rearomatization yields the functionalized pyridine.[3][4][5]
- **Photocatalysis and Electrochemistry:** These methods can generate radical species that react with pyridine with distinct regioselectivity profiles compared to traditional ionic reactions.[6][7]

Q3: How can I achieve functionalization at the C3 (meta) position of pyridine?

A3: C3-functionalization is challenging due to the electron-deficient nature of the pyridine ring. However, several methods have been developed:

- **Electrophilic Aromatic Substitution:** While pyridine is generally unreactive towards electrophiles, forcing conditions (e.g., high temperatures, strong acids) can lead to C3 substitution for reactions like nitration and halogenation, though yields can be low.[5]
- **Directed Metalation:** Using a directing group at the C2 or C4 position can direct metalation (e.g., with lithium or magnesium bases) to the C3 position. The resulting organometallic intermediate can then be quenched with an electrophile.[8]
- **Dearomatization-Rearomatization:** This strategy involves converting the pyridine into a more reactive, non-aromatic intermediate that can then be functionalized at the C3 position before

re-aromatizing.[3][4][5]

Q4: My Minisci reaction is giving a mixture of C2 and C4 isomers. How can I improve C4 selectivity?

A4: The Minisci reaction, which involves the addition of a radical to a protonated pyridine, often yields a mixture of C2 and C4 products. To enhance C4 selectivity:

- **Steric Hindrance:** Introducing a bulky substituent at the C2 position can sterically block radical attack, favoring the C4 position.
- **Blocking Groups:** A removable bulky group can be temporarily installed on the nitrogen atom to sterically hinder the C2 and C6 positions, thus directing the incoming radical to the C4 position. A maleate-derived blocking group has been shown to be effective for this purpose. [9][10]
- **Solvent and pH:** The regioselectivity of radical additions can be influenced by the solvent and pH of the reaction medium. Systematic screening of these parameters can help optimize for C4 selectivity.[11]

Troubleshooting Guides

Issue 1: Low Yield in Palladium-Catalyzed C-H Arylation

Problem: My palladium-catalyzed C-H arylation of a pyridine derivative is resulting in a low yield of the desired product.

Possible Cause	Solution
Catalyst Poisoning	The nitrogen atom of the pyridine can coordinate strongly to the palladium catalyst, leading to deactivation. ^{[12][13]} Solution: Use a higher catalyst loading, or employ a pre-catalyst that is less susceptible to poisoning. In some cases, the use of N-oxide derivatives of the pyridine substrate can prevent catalyst poisoning. ^[14]
Incorrect Ligand	The choice of ligand is crucial for the efficiency of the catalytic cycle. Solution: Screen a variety of phosphine or N-heterocyclic carbene (NHC) ligands. The optimal ligand will depend on the specific substrate and reaction conditions. ^{[15][16][17][18]}
Suboptimal Base or Solvent	The base and solvent can significantly impact the reaction rate and yield. ^[19] Solution: Perform a systematic screen of different bases (e.g., carbonates, phosphates, carboxylates) and solvents (e.g., dioxane, toluene, DMF).
Poor Substrate Reactivity	The electronic and steric properties of the pyridine substrate can affect its reactivity. Solution: If possible, modify the substituents on the pyridine ring to enhance its reactivity. For example, electron-donating groups can sometimes improve the efficiency of C-H activation.

Issue 2: Poor Regioselectivity in Nucleophilic Aromatic Substitution (SNAr)

Problem: My SNAr reaction on a substituted pyridine is giving a mixture of regioisomers.

Possible Cause	Solution
Competing Reaction Sites	If the pyridine has multiple leaving groups or activated positions, the nucleophile may attack at more than one site. Solution: If possible, use a substrate with a single, highly activated position for nucleophilic attack. Alternatively, blocking groups can be used to deactivate competing sites.
Thermodynamic vs. Kinetic Control	The regioselectivity of the reaction may be dependent on the reaction temperature and time. Solution: Try running the reaction at a lower temperature to favor the kinetically controlled product, or at a higher temperature for a longer period to favor the thermodynamically more stable product.
Nature of the Nucleophile	The size and hardness/softness of the nucleophile can influence where it attacks the pyridine ring. Solution: Consider using a different nucleophile with different steric or electronic properties.

Data Presentation: Comparison of Catalytic Systems for Pyridine C-H Arylation

Parameter	Palladium-Catalyzed C-H Arylation	Photocatalytic C-H Arylation
Catalyst System	Pd(OAc) ₂ , PdCl ₂ , or other Pd salts with a ligand (e.g., phosphines, NHCs)	Ru(bpy) ₃ Cl ₂ , Ir(ppy) ₃ , or organic photocatalysts
Typical Catalyst Loading	1-10 mol%	0.5-5 mol%
Reactants	Pyridine derivative, aryl halide or arylboronic acid	Pyridine derivative, aryl diazonium salt or other radical precursor
Reaction Temperature	80-150 °C	Room temperature to 60 °C
Advantages	Well-established, broad substrate scope, high yields achievable.	Mild reaction conditions, often complementary regioselectivity to Pd-catalysis, environmentally friendly.
Disadvantages	High temperatures, potential for catalyst poisoning, often requires a directing group for high regioselectivity.	Can be sensitive to oxygen and light, substrate scope may be more limited for certain transformations.

Experimental Protocols

Protocol 1: General Procedure for Photocatalytic C4-Alkylation of Pyridine

This protocol is a general guideline for the C4-alkylation of pyridine using a photocatalytic approach.

Materials:

- Pyridine derivative (1.0 equiv)
- Alkyl carboxylic acid (as a radical precursor, 1.5-3.0 equiv)
- Photocatalyst (e.g., Ru(bpy)₃Cl₂, 1-2 mol%)

- Base (e.g., Cs₂CO₃, 2.0 equiv)
- Solvent (e.g., DMSO, DMF, or acetonitrile)
- Inert atmosphere (Nitrogen or Argon)
- Visible light source (e.g., blue LED lamp)

Procedure:

- To an oven-dried reaction vessel, add the pyridine derivative, alkyl carboxylic acid, photocatalyst, and base.
- Evacuate and backfill the vessel with an inert gas (e.g., nitrogen or argon) three times.
- Add the degassed solvent via syringe.
- Stir the reaction mixture at room temperature and irradiate with a visible light source (e.g., a blue LED lamp) for 12-24 hours.
- Monitor the reaction progress by TLC or LC-MS.
- Upon completion, quench the reaction with water and extract the product with an organic solvent (e.g., ethyl acetate).
- Combine the organic layers, dry over anhydrous sodium sulfate, filter, and concentrate under reduced pressure.
- Purify the crude product by column chromatography on silica gel.

Protocol 2: General Procedure for Palladium-Catalyzed C2-Arylation of Pyridine using a Directing Group

This protocol outlines a general procedure for the C2-arylation of 2-substituted pyridines.

Materials:

- 2-Substituted pyridine (e.g., 2-phenylpyridine, 1.0 equiv)

- Aryl halide (e.g., aryl bromide, 1.2 equiv)
- Palladium catalyst (e.g., Pd(OAc)₂, 5 mol%)
- Ligand (e.g., PPh₃, 10 mol%)
- Base (e.g., K₂CO₃, 2.0 equiv)
- Solvent (e.g., toluene or dioxane)
- Inert atmosphere (Nitrogen or Argon)

Procedure:

- To an oven-dried Schlenk tube, add the 2-substituted pyridine, aryl halide, palladium catalyst, ligand, and base.
- Evacuate and backfill the tube with an inert gas three times.
- Add the degassed solvent via syringe.
- Heat the reaction mixture to 100-120 °C and stir for 12-24 hours.
- Monitor the reaction progress by TLC or GC-MS.
- Upon completion, cool the reaction to room temperature, dilute with an organic solvent, and filter through a pad of Celite.
- Wash the filtrate with water and brine, then dry the organic layer over anhydrous sodium sulfate.
- Filter and concentrate the organic layer under reduced pressure.
- Purify the crude product by column chromatography on silica gel.

Mandatory Visualizations

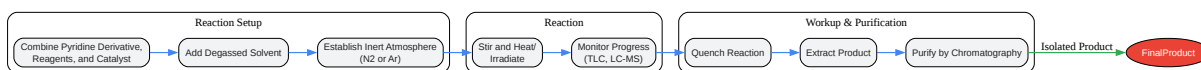

[Click to download full resolution via product page](#)

Caption: A generalized experimental workflow for pyridine functionalization reactions.

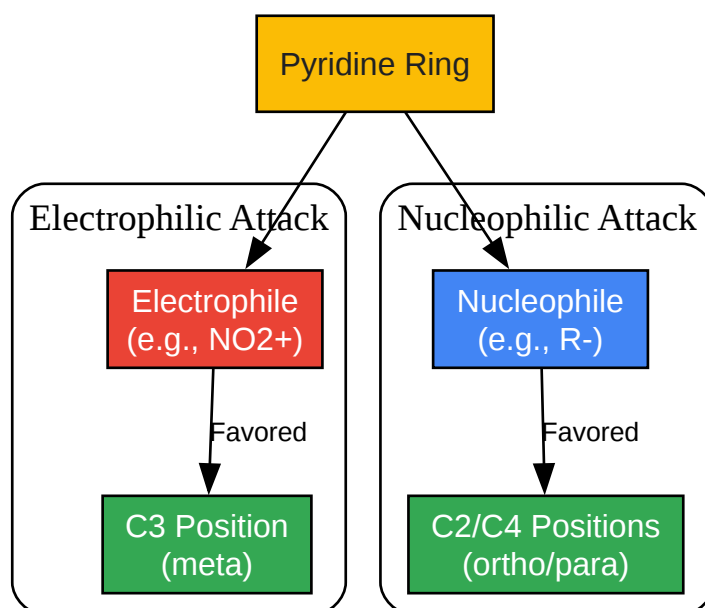

[Click to download full resolution via product page](#)

Caption: Logical relationship governing the regioselectivity of attacks on the pyridine ring.

Need Custom Synthesis?

BenchChem offers custom synthesis for rare earth carbides and specific isotopic labeling.

Email: info@benchchem.com or [Request Quote Online](#).

References

- 1. BJOC - Pyridine C(sp²)-H bond functionalization under transition-metal and rare earth metal catalysis [beilstein-journals.org]
- 2. C-H functionalization of pyridines - Organic & Biomolecular Chemistry (RSC Publishing) [pubs.rsc.org]
- 3. Reaction strategies for the meta-selective functionalization of pyridine through dearomatization - PubMed [pubmed.ncbi.nlm.nih.gov]
- 4. meta-Selective C-H Functionalization of Pyridines - PubMed [pubmed.ncbi.nlm.nih.gov]
- 5. researchgate.net [researchgate.net]
- 6. researchgate.net [researchgate.net]
- 7. recercat.cat [recercat.cat]
- 8. Regioselective Functionalization of Pyridines using a Directed Metalation or a Halogen/Metal Exchange [znaturforsch.com]
- 9. Practical and Regioselective Synthesis of C4-Alkylated Pyridines - PMC [pmc.ncbi.nlm.nih.gov]
- 10. Practical and Regioselective Synthesis of C-4-Alkylated Pyridines [organic-chemistry.org]
- 11. Radical-Based Regioselective C-H Functionalization of Electron-Deficient Heteroarenes: Scope, Tunability, and Predictability - PMC [pmc.ncbi.nlm.nih.gov]
- 12. benchchem.com [benchchem.com]
- 13. benchchem.com [benchchem.com]
- 14. pubs.acs.org [pubs.acs.org]
- 15. Intramolecular C-H arylation of pyridine derivatives with a palladium catalyst for the synthesis of multiply fused heteroaromatic compounds - PMC [pmc.ncbi.nlm.nih.gov]
- 16. researchgate.net [researchgate.net]
- 17. Beilstein Archives - Intramolecular C-H arylation of pyridine derivatives with a palladium catalyst for the synthesis of multiply-fused heteroaromatic compounds [beilstein-archives.org]
- 18. Intramolecular C-H arylation of pyridine derivatives with a palladium catalyst for the synthesis of multiply fused heteroaromatic compounds - PubMed [pubmed.ncbi.nlm.nih.gov]
- 19. researchgate.net [researchgate.net]
- To cite this document: BenchChem. [Technical Support Center: Improving Regioselectivity in Pyridine Functionalization]. BenchChem, [2026]. [Online PDF]. Available at:

[\[https://www.benchchem.com/product/b581361/docs#technical-support-center-improving-regioselectivity-in-pyridine-functionalization\]](https://www.benchchem.com/product/b581361/docs#technical-support-center-improving-regioselectivity-in-pyridine-functionalization)

Disclaimer & Data Validity:

The information provided in this document is for Research Use Only (RUO) and is strictly not intended for diagnostic or therapeutic procedures. While BenchChem strives to provide accurate protocols, we make no warranties, express or implied, regarding the fitness of this product for every specific experimental setup.

Technical Support: The protocols provided are for reference purposes. Unsure if this reagent suits your experiment?

Need Industrial/Bulk Grade? [Request Custom Synthesis Quote](#)

BenchChem

Our mission is to be the trusted global source of essential and advanced chemicals, empowering scientists and researchers to drive progress in science and industry.

Contact

Address: 3281 E Guasti Rd
Ontario, CA 91761, United States
Phone: (601) 213-4426
Email: info@benchchem.com

[Contact our Ph.D. Support Team for a compatibility check](#)