

# Introduction: The Analytical Imperative for 7-Octenyl Acetate

**Author:** BenchChem Technical Support Team. **Date:** May 2026

## Compound of Interest

Compound Name: 7-Octenyl Acetate

CAS No.: 5048-35-1

Cat. No.: B1315577

[Get Quote](#)

**7-Octenyl acetate** (C<sub>10</sub>H<sub>18</sub>O<sub>2</sub>) is a volatile organic ester recognized for its distinct fruity and green aroma profile.[1] This characteristic makes it a valuable ingredient in the fragrance, flavor, and consumer product industries, where it imparts fresh notes to perfumes, food products, and personal care items.[1] Given its impact on product quality and sensory experience, a robust and reliable analytical method for the unequivocal identification and precise quantification of **7-octenyl acetate** is paramount. Gas Chromatography-Mass Spectrometry (GC-MS) stands as the gold-standard technique for this application, offering superior chromatographic separation and definitive mass-based identification.

This guide provides a comprehensive, field-proven protocol for the analysis of **7-octenyl acetate**. It is designed for researchers and quality control scientists, detailing every critical step from sample preparation to data interpretation, and explaining the scientific rationale behind each procedural choice to ensure methodological integrity and reproducibility.

## Principle of the GC-MS Method

The analysis leverages the power of Gas Chromatography (GC) to separate **7-octenyl acetate** from other volatile and semi-volatile components within a sample matrix. The sample, once

injected into the instrument, is vaporized and carried by an inert gas through a capillary column. The column's stationary phase interacts differently with each compound based on properties like boiling point and polarity, causing them to elute at distinct times (retention times). As **7-octenyl acetate** exits the GC column, it enters the Mass Spectrometer (MS). Here, it is fragmented into characteristic, predictable ions by electron ionization (EI). The mass analyzer then separates these ions based on their mass-to-charge ratio ( $m/z$ ), generating a unique mass spectrum that serves as a chemical fingerprint for definitive identification.

## Materials and Reagents

- Analytical Standard: **7-Octenyl acetate**,  $\geq 98\%$  purity
- Solvent: Hexane or Dichloromethane (GC or HPLC grade)
- Internal Standard (Optional, for quantification): n-Dodecane or another suitable non-interfering compound.
- Gases: Helium (99.999% purity) or Hydrogen (99.999% purity) for carrier gas; Nitrogen for makeup gas if required.
- Consumables: 2 mL GC vials with PTFE-lined septa, autosampler syringes, 0.22  $\mu\text{m}$  syringe filters (if samples contain particulates).

## Instrumentation and Analytical Conditions

A standard Gas Chromatograph coupled with a single quadrupole Mass Spectrometer is required. The following parameters serve as a robust starting point and should be optimized for specific instrumentation and matrices.

## Rationale for Parameter Selection

- Column Choice: A non-polar 5% phenyl-methylpolysiloxane stationary phase (e.g., HP-5ms, DB-5ms) is selected. This is the industry workhorse for general volatile and semi-volatile analysis. It separates compounds primarily by boiling point, which is effective for a moderately polar ester like **7-octenyl acetate** in complex mixtures.
- Inlet Temperature: Set at 250°C, this temperature ensures the rapid and complete vaporization of **7-octenyl acetate** (Boiling Point: 104°C at 18mmHg) and other analytes

without causing thermal degradation.[1][2]

- Oven Program: The program starts at a low temperature (60°C) to trap and focus the analytes at the head of the column, ensuring sharp peaks. The ramp to 240°C at 10°C/min provides efficient separation of compounds with varying boiling points.[3][4]
- MS Parameters: Electron ionization at the standard 70 eV provides reproducible fragmentation patterns that are comparable to established mass spectral libraries like NIST for confident identification.[5] The scan range of m/z 40-250 is chosen to encompass the expected molecular ion (m/z 170.13) and key fragment ions while avoiding interference from low-mass ions like air and water.[6]

## Instrument Parameters Table

Parameter	Setting
Gas Chromatograph (GC)	
GC Column	HP-5ms (or equivalent), 30 m x 0.25 mm ID, 0.25 µm film thickness
Carrier Gas	Helium, Constant Flow Rate: 1.0 mL/min
Inlet	Split/Splitless
Inlet Temperature	250°C
Injection Volume	1 µL
Split Ratio	20:1 (Adjust based on sample concentration)
Oven Temperature Program	Initial: 60°C (hold 2 min), Ramp: 10°C/min to 240°C (hold 5 min)
Mass Spectrometer (MS)	
Ion Source Temperature	230°C
Quadrupole Temperature	150°C
Ionization Mode	Electron Ionization (EI)
Electron Energy	70 eV
Mass Scan Range	m/z 40 - 250
Solvent Delay	3.0 minutes (to prevent filament damage from the solvent peak)

## Analytical Workflow Diagram

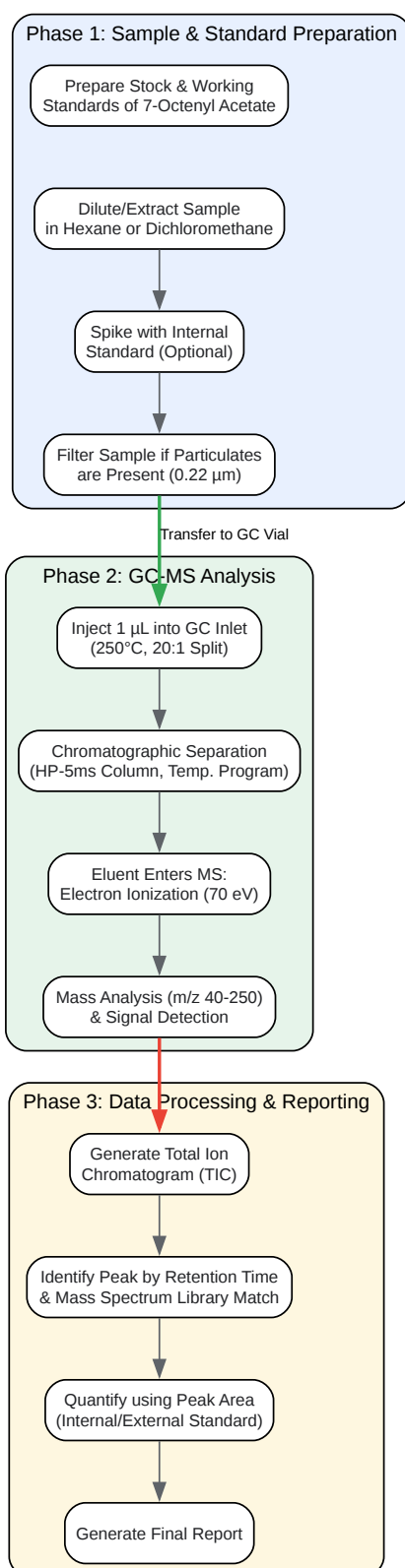

[Click to download full resolution via product page](#)

Caption: GC-MS analytical workflow for **7-octenyl acetate**.

## Step-by-Step Experimental Protocols

### Preparation of Standard Solutions

The creation of accurate standards is the foundation of reliable quantification.

- **Primary Stock Standard (1000 µg/mL):** Accurately weigh 10 mg of pure **7-octenyl acetate** standard. Transfer it quantitatively to a 10 mL volumetric flask. Dissolve and bring to volume with hexane. This stock should be stored at 4°C in an amber vial.
- **Working Standards:** Prepare a series of calibration standards (e.g., 1, 5, 10, 25, 50 µg/mL) by serially diluting the primary stock standard with hexane in volumetric flasks.
- **Internal Standard (IS) Spiking:** If using an internal standard for improved precision, add a constant concentration (e.g., 10 µg/mL of n-dodecane) to each working standard and sample.

### Sample Preparation

The goal is to produce a clean, particle-free sample in a volatile solvent suitable for GC injection.<sup>[7][8]</sup>

- **Liquid Samples (e.g., fragrance oils, beverages):**
  - Accurately weigh approximately 1 g of the homogenized sample into a 10 mL volumetric flask.
  - Add the internal standard solution, if used.
  - Dilute to volume with hexane.
  - Vortex for 1 minute to ensure thorough extraction.
- **Solid/Semi-Solid Samples (e.g., creams, powders):**
  - Accurately weigh ~1 g of sample into a centrifuge tube.
  - Add 5 mL of hexane and the internal standard.

- Vortex for 2 minutes, then sonicate for 10 minutes to facilitate extraction.
- Centrifuge at 3000 rpm for 5 minutes to pellet insoluble matter.
- Final Preparation (All Samples):
  - Carefully transfer an aliquot of the supernatant or diluted sample into a 2 mL GC vial. If any particulates are visible, pass the aliquot through a 0.22  $\mu\text{m}$  PTFE syringe filter directly into the vial.<sup>[7]</sup> This prevents contamination of the GC inlet liner.<sup>[9]</sup>

## Data Acquisition and Interpretation

- Sequence Setup: Create a sequence in the instrument control software. Include solvent blanks, calibration standards (from low to high concentration), and samples.
- Data Review: After the run, examine the Total Ion Chromatogram (TIC).
- Peak Identification:
  - Retention Time (RT): The peak corresponding to **7-octenyl acetate** should appear at a consistent RT, matching that of the analytical standards.
  - Mass Spectrum: Extract the mass spectrum from the apex of the target peak. It should be compared to a reference spectrum from a trusted library (e.g., NIST). The mass spectrum of **7-octenyl acetate** is characterized by its molecular ion ( $\text{M}^+$ ) at  $m/z$  170 and key fragment ions. A prominent fragment is expected at  $m/z$  43, corresponding to the acetyl group  $[\text{CH}_3\text{CO}]^+$ . Another characteristic fragmentation pathway for esters is the loss of acetic acid, which would result in a fragment at  $m/z$  110 ( $170 - 60$ ).
- Quantification:
  - Generate a calibration curve by plotting the peak area of **7-octenyl acetate** (or the ratio of its area to the internal standard's area) against the concentration of the working standards.
  - The linearity of the curve should be verified ( $R^2 \geq 0.995$ ).
  - Calculate the concentration of **7-octenyl acetate** in the unknown samples using the regression equation derived from the calibration curve.

## Conclusion

This application note provides a validated and robust GC-MS protocol for the analysis of **7-octenyl acetate**. The detailed steps for sample preparation and the optimized instrument parameters are designed to deliver high-quality, reproducible results. The combination of chromatographic separation by retention time and definitive identification by mass spectral fingerprinting makes this method highly reliable for quality control, research, and product development applications involving this important flavor and fragrance compound.

## References

- National Center for Biotechnology Information (2024). PubChem Compound Summary for CID 13990525, Oct-7-enyl acetate. Available at: [\[Link\]](#)
- The Good Scents Company (n.d.). (E)-2-octen-1-yl acetate. Available at: [\[Link\]](#)
- National Center for Biotechnology Information (2024). PubChem Compound Summary for CID 8164, Octyl Acetate. Available at: [\[Link\]](#)
- MySkinRecipes (n.d.). **7-Octenyl Acetate**. Available at: [\[Link\]](#)
- National Center for Biotechnology Information (2024). PubChem Compound Summary for CID 17121, 1-Octen-3-yl acetate. Available at: [\[Link\]](#)
- National Institute of Standards and Technology (n.d.). 6-Octen-1-ol, 3,7-dimethyl-, acetate in NIST WebBook. Available at: [\[Link\]](#)
- Agilent Technologies (2005). Column Selection for the Analysis of Fatty Acid Methyl Esters. Available at: [\[Link\]](#)
- SCION Instruments (n.d.). Sample preparation GC-MS. Available at: [\[Link\]](#)
- CORESTA (2019). Analysis of organic acetates in e-vapor products by GC-MS/MS. Available at: [\[Link\]](#)
- MDPI (2022). Quantitative Method for Analysis of Lipids by LC-HRMS and Fatty Acid Methyl Ester by GC-FID in Macauba (*Acrocomia aculeata*) Oils. Available at: [\[Link\]](#)

- Organomation (n.d.). GC-MS Sample Preparation. Available at: [\[Link\]](#)
- ResearchGate (2014). Preparation of Samples for Gas Chromatography/Mass Spectrometry Analysis of Phthalate and Adipate Esters in Plasma and Beverages by Steam Distillation and Extraction. Available at: [\[Link\]](#)
- Greyhound Chromatography (n.d.). GC Column Selection Guide. Available at: [\[Link\]](#)
- SciSpace (2012). Sample Preparation Techniques for Gas Chromatography. Available at: [\[Link\]](#)
- The Good Scents Company (n.d.). octyl acetate. Available at: [\[Link\]](#)
- SciELO (2017). Determination of Alkyl Esters Content by Gas Chromatography: Validation of Method Based on Short Column and Response Factor. Available at: [\[Link\]](#)
- Swedish National Food Agency (2013). Analysis of pesticide residues in fruit and vegetables with ethyl acetate extraction using gas and liquid chromatography with tandem mass spectrometric detection. Available at: [\[Link\]](#)

### *Need Custom Synthesis?*

*BenchChem offers custom synthesis for rare earth carbides and specific isotopic labeling.*

*Email: [info@benchchem.com](mailto:info@benchchem.com) or [Request Quote Online](#).*

## Sources

- 1. 7-Octenyl Acetate [[myskinrecipes.com](http://myskinrecipes.com)]
- 2. 7-Octenyl Acetate 98.0+%, TCI America™ | Fisher Scientific [[fishersci.ca](http://fishersci.ca)]
- 3. Fatty Acid Methyl Ester analysis by Gas Chromatography [[sigmaaldrich.com](http://sigmaaldrich.com)]
- 4. [scielo.br](http://scielo.br) [[scielo.br](http://scielo.br)]
- 5. 6-Octen-1-ol, 3,7-dimethyl-, acetate [[webbook.nist.gov](http://webbook.nist.gov)]
- 6. Oct-7-enyl acetate | C<sub>10</sub>H<sub>18</sub>O<sub>2</sub> | CID 13990525 - PubChem [[pubchem.ncbi.nlm.nih.gov](http://pubchem.ncbi.nlm.nih.gov)]
- 7. Sample preparation GC-MS [[scioninstruments.com](http://scioninstruments.com)]

- [8. GC-MS Sample Preparation | Thermo Fisher Scientific - KR \[thermofisher.com\]](#)
- [9. organomation.com \[organomation.com\]](#)
- To cite this document: BenchChem. [Introduction: The Analytical Imperative for 7-Octenyl Acetate]. BenchChem, [2026]. [Online PDF]. Available at: [\[https://www.benchchem.com/product/b1315577/docs#introduction-the-analytical-imperative-for-7-octenyl-acetate\]](https://www.benchchem.com/product/b1315577/docs#introduction-the-analytical-imperative-for-7-octenyl-acetate)

---

### Disclaimer & Data Validity:

The information provided in this document is for Research Use Only (RUO) and is strictly not intended for diagnostic or therapeutic procedures. While BenchChem strives to provide accurate protocols, we make no warranties, express or implied, regarding the fitness of this product for every specific experimental setup.

**Technical Support:** The protocols provided are for reference purposes. Unsure if this reagent suits your experiment?

**Need Industrial/Bulk Grade?** [Request Custom Synthesis Quote](#)

## BenchChem

Our mission is to be the trusted global source of essential and advanced chemicals, empowering scientists and researchers to drive progress in science and industry.

### Contact

Address: 3281 E Guasti Rd  
Ontario, CA 91761, United States  
Phone: (601) 213-4426  
Email: [info@benchchem.com](mailto:info@benchchem.com)

[Contact our Ph.D. Support Team for a compatibility check](#)