

Application Notes and Protocols for Electroantennography (EAG) Studies Using 7-Octenyl Acetate

Author: BenchChem Technical Support Team. **Date:** May 2026

Compound of Interest

Compound Name: 7-Octenyl Acetate

CAS No.: 5048-35-1

Cat. No.: B1315577

[Get Quote](#)

Introduction: Decoding Olfactory Signals with 7-Octenyl Acetate

In the intricate world of insect chemical communication, volatile organic compounds (VOCs) serve as a primary language, dictating behaviors critical for survival and reproduction. Among these semiochemicals, esters form a significant class of compounds involved in everything from mate attraction to host-plant localization.[1][2] **7-Octenyl acetate** (CAS 5048-35-1), a C10 acetate ester, is one such molecule of interest in the field of chemical ecology.[3]

Understanding how an insect's olfactory system detects and processes this compound is fundamental to deciphering its ecological role and potentially leveraging it for pest management strategies.[4]

Electroantennography (EAG) is a powerful electrophysiological technique that provides a direct measure of the summed electrical response of an insect's antenna to an olfactory stimulus.[5] [6] Developed by Dietrich Schneider in 1957, this method allows researchers to screen compounds for olfactory activity, determine detection thresholds, and compare the sensitivity of

different species or sexes to a particular odorant.[5] The resulting EAG signal represents the sum of depolarizations of numerous olfactory receptor neurons (ORNs) upon exposure to a volatile chemical.[5][7]

These application notes provide a comprehensive guide for researchers, scientists, and drug development professionals on the effective use of **7-octenyl acetate** in EAG studies. We will delve into the core principles of insect olfaction, provide detailed, field-proven protocols for every stage of the EAG process, and offer insights into data analysis and interpretation, ensuring scientific integrity and trustworthy, reproducible results.

Core Principles of Insect Olfaction and EAG Signal Generation

An insect's antenna is a marvel of biological engineering, adorned with specialized sensory hairs called sensilla. Within these sensilla reside the ORNs, the primary detectors of airborne chemical cues. The process of odorant detection is a multi-step cascade:

- **Odorant Entry and Transport:** Volatile molecules like **7-octenyl acetate** enter the sensilla through nanopores in the cuticle. Once inside the aqueous sensillar lymph, they are bound and solubilized by Odorant-Binding Proteins (OBPs).[8]
- **Receptor Activation:** The OBP-odorant complex transports the molecule to the dendritic membrane of an ORN, where it interacts with a specific Olfactory Receptor (OR). Insect ORs are typically heterodimeric complexes, consisting of a variable, odorant-specific subunit (OrX) and a highly conserved co-receptor (Orco).[9]
- **Signal Transduction:** The binding of **7-octenyl acetate** to its cognate receptor induces a conformational change, opening an ion channel. This leads to an influx of cations and the depolarization of the ORN's membrane.
- **The EAG Signal:** The EAG technique measures the summated potential changes across a large population of responding ORNs between the base and the tip of the antenna.[5][7] The amplitude of the resulting negative voltage deflection is proportional to the number of activated ORNs and the intensity of their response, which in turn is dependent on the odorant concentration.[5]

Experimental Protocols

This section provides detailed, step-by-step methodologies for conducting EAG experiments with **7-octenyl acetate**. Adherence to these protocols is critical for obtaining high-quality, reproducible data.

PART 1: Preparation of 7-Octenyl Acetate Stimulus Solutions

The accurate and consistent preparation of odorant stimuli is paramount for reliable dose-response studies.

Causality Behind Experimental Choices:

- **Solvent Selection:** The choice of solvent is critical. It must effectively dissolve the nonpolar **7-octenyl acetate**, be of high purity to avoid introducing confounding stimuli, and have low inherent EAG activity itself. Hexane or paraffin oil are commonly used for this purpose.[7] It is crucial to perform a solvent control in every experiment to ensure the solvent itself does not elicit a significant antennal response.
- **Serial Dilutions:** A logarithmic series of dilutions (e.g., 10^{-5} to 10^{-1} M) is prepared to construct a dose-response curve. This allows for the determination of the antenna's sensitivity threshold and its dynamic range of response to **7-octenyl acetate**.

Step-by-Step Methodology:

- **Stock Solution Preparation:** Prepare a 1 M stock solution of **7-octenyl acetate** in high-purity hexane or paraffin oil.
- **Serial Dilutions:** Perform serial dilutions to obtain a range of concentrations. For example, to create a 10^{-2} M solution, dilute 10 μ L of the 1 M stock solution in 990 μ L of the chosen solvent. Repeat this process for each desired concentration.
- **Stimulus Cartridge Preparation:** Apply a known volume (e.g., 10 μ L) of each dilution onto a small piece of filter paper (e.g., 1 cm^2). Allow the solvent to evaporate for a few seconds, leaving the **7-octenyl acetate** adsorbed to the paper.

- **Cartridge Insertion:** Immediately insert the filter paper into a clean Pasteur pipette or a dedicated stimulus cartridge. Seal the ends with paraffin film to prevent premature volatilization. Prepare a solvent-only control cartridge in the same manner.

Parameter	Recommendation	Rationale
Compound Purity	>95%	To ensure the observed response is to 7-octenyl acetate and not impurities.
Solvent	High-purity hexane or paraffin oil	Good solvating power for nonpolar compounds and low intrinsic EAG activity.
Concentration Range	10^{-5} M to 10^{-1} M (or as determined by pilot studies)	To establish a clear dose-response relationship.
Application Volume	10 μ L onto filter paper	A standardized volume for consistent stimulus loading.

PART 2: Insect and Antenna Preparation

Proper preparation of the insect antenna is crucial for stable and reliable recordings. The goal is to establish a low-resistance electrical contact between the electrodes and the hemolymph within the antenna.

Causality Behind Experimental Choices:

- **Immobilization:** The insect must be gently but firmly immobilized to prevent movement artifacts that can introduce noise into the recording.[\[5\]](#)
- **Antenna Excision:** For many insects, excising the antenna allows for more stable and direct contact with the electrodes.[\[5\]](#)[\[10\]](#)
- **Electrode Contact:** Creating a good electrical connection is vital. This is typically achieved by removing a small portion of the antennal tip to expose the hemolymph and inserting the basal end into an electrode filled with a conductive saline solution.[\[5\]](#)[\[11\]](#)

Step-by-Step Methodology:

- Insect Immobilization: Anesthetize the insect by chilling it on ice or with a brief exposure to CO₂.^[11] Secure the insect's head in a holder (e.g., a wax or clay block) under a dissecting microscope, leaving the antennae freely accessible.
- Antenna Excision: Using fine microscissors, carefully excise one antenna at its base (scape).^[5]
- Reference Electrode Placement: Insert the reference electrode (a glass capillary filled with saline solution and containing a silver wire) into the back of the head capsule.
- Recording Electrode and Antenna Mounting:
 - Trim a tiny portion of the distal tip of the excised antenna with a sharp blade to ensure good electrical contact.
 - Mount the basal end of the antenna onto the recording electrode, which is also filled with saline solution. Ensure a secure connection where the hemolymph is in contact with the saline.

Diagram of EAG Preparation Workflow

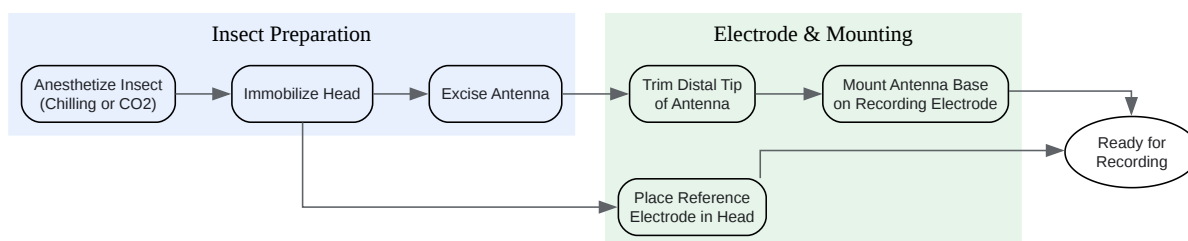

[Click to download full resolution via product page](#)

Caption: Workflow for insect and antenna preparation for EAG recording.

PART 3: Data Acquisition and Analysis

This phase involves delivering the odorant stimulus to the prepared antenna and recording the resulting electrical signals.

Causality Behind Experimental Choices:

- **Airflow:** A continuous stream of purified, humidified air is passed over the antenna to provide a stable baseline and to carry the odorant puff.[10] Humidification prevents the antenna from desiccating.
- **Stimulus Delivery:** The odorant is introduced into the airstream as a brief, controlled puff. This ensures a sharp onset and termination of the stimulus, leading to a well-defined EAG response.
- **Controls:** A solvent control and a positive control (a known EAG-active compound) should be used in every experiment to validate the preparation's responsiveness and to provide a reference for normalization.[7]
- **Normalization:** Raw EAG amplitudes can vary between preparations due to differences in antenna size, age, or recording quality. To allow for meaningful comparisons, responses are often normalized as a percentage of the response to a standard reference compound.[5]

Step-by-Step Methodology:

- **System Setup:** Place the prepared antenna in the path of a continuous stream of charcoal-filtered, humidified air (e.g., at 0.5 L/min). Position the tip of the stimulus delivery tube close to the antenna (e.g., 1 cm).
- **Recording Baseline:** Allow the antenna to acclimatize to the airflow for a few minutes until a stable baseline is observed on the recording software.
- **Stimulus Presentation:**
 - Begin by presenting the solvent control to ensure no significant response is elicited.
 - Present the **7-octenyl acetate** dilutions in ascending order of concentration.
 - Deliver each stimulus as a short puff (e.g., 0.5 seconds) into the main airstream.

- Allow sufficient time between stimuli (e.g., 30-60 seconds) for the antenna to recover and the baseline to stabilize.
- Periodically present the positive control to monitor the health and responsiveness of the preparation.
- Data Recording: Record the voltage changes using an appropriate amplifier and data acquisition software. The peak amplitude of the negative voltage deflection is the primary measure of the EAG response.
- Data Analysis:
 - Measure the peak amplitude of the response to each stimulus, subtracting the average baseline value.
 - Subtract the solvent control response from all other responses.
 - Normalize the data by expressing the response to **7-octenyl acetate** as a percentage of the response to the positive control.
 - Plot the normalized EAG response against the logarithm of the **7-octenyl acetate** concentration to generate a dose-response curve.
 - Use appropriate statistical tests (e.g., ANOVA followed by a post-hoc test) to compare responses across different concentrations.[\[12\]](#)

Diagram of EAG Data Acquisition

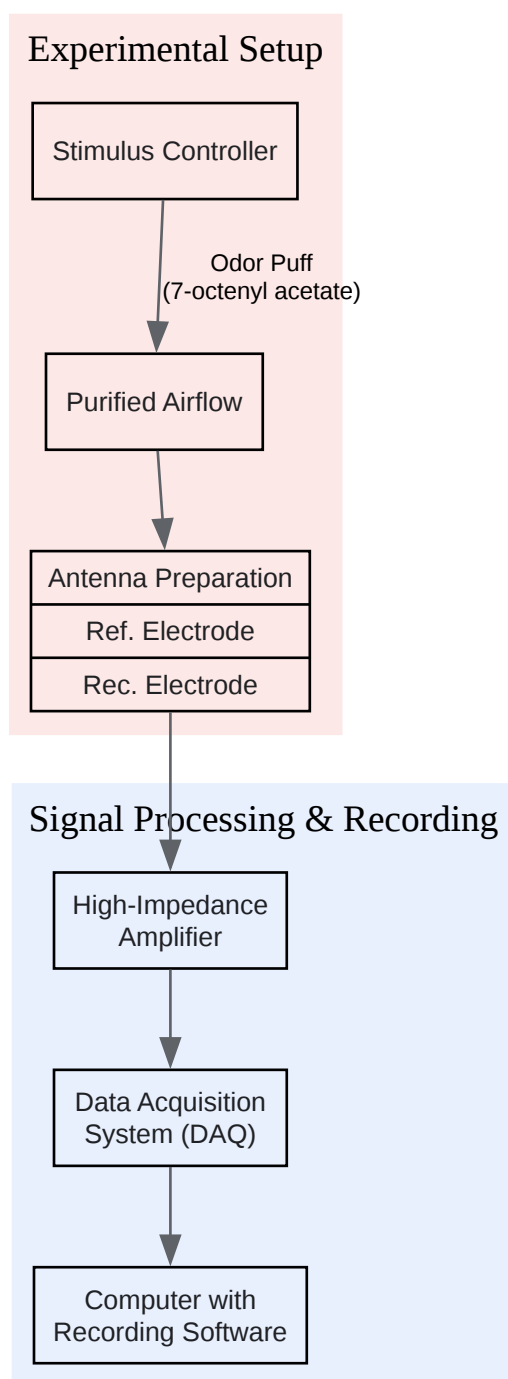

[Click to download full resolution via product page](#)

Need Custom Synthesis?

BenchChem offers custom synthesis for rare earth carbides and specific isotopic labeling.

Email: info@benchchem.com or [Request Quote Online](#).

Sources

- [1. researchgate.net \[researchgate.net\]](#)
- [2. Olfactory and behavioral responses to acetate esters in red imported fire ant, *Solenopsis invicta* - PubMed \[pubmed.ncbi.nlm.nih.gov\]](#)
- [3. Oct-7-enyl acetate | C10H18O2 | CID 13990525 - PubChem \[pubchem.ncbi.nlm.nih.gov\]](#)
- [4. agriculture.basf.com \[agriculture.basf.com\]](#)
- [5. ockenfels-syntech.com \[ockenfels-syntech.com\]](#)
- [6. researchgate.net \[researchgate.net\]](#)
- [7. A Step-by-Step Guide to Mosquito Electroantennography \[jove.com\]](#)
- [8. Insect Receptors: Biochemical, Physiological and Molecular Studies | MDPI \[mdpi.com\]](#)
- [9. Phenethyl Acetate as an Agonist of Insect Odorant Receptor Co-Receptor \(Orco\): Molecular Mechanisms and Functional Insights - PMC \[pmc.ncbi.nlm.nih.gov\]](#)
- [10. youtube.com \[youtube.com\]](#)
- [11. Using Insect Electroantennogram Sensors on Autonomous Robots for Olfactory Searches - PMC \[pmc.ncbi.nlm.nih.gov\]](#)
- [12. researchgate.net \[researchgate.net\]](#)
- To cite this document: BenchChem. [Application Notes and Protocols for Electroantennography (EAG) Studies Using 7-Octenyl Acetate]. BenchChem, [2026]. [Online PDF]. Available at: [<https://www.benchchem.com/product/b1315577/docs#application-notes-and-protocols-for-electroantennography-eag-studies-using-7-octenyl-acetate>]

Disclaimer & Data Validity:

The information provided in this document is for Research Use Only (RUO) and is strictly not intended for diagnostic or therapeutic procedures. While BenchChem strives to provide accurate protocols, we make no warranties, express or implied, regarding the fitness of this product for every specific experimental setup.

Technical Support: The protocols provided are for reference purposes. Unsure if this reagent suits your experiment?

Need Industrial/Bulk Grade? [Request Custom Synthesis Quote](#)

BenchChem

Our mission is to be the trusted global source of essential and advanced chemicals, empowering scientists and researchers to drive progress in science and industry.

Contact

Address: 3281 E Guasti Rd

Ontario, CA 91761, United States

Phone: (601) 213-4426

Email: info@benchchem.com

[Contact our Ph.D. Support Team for a compatibility check](#)