

A Comprehensive Spectroscopic Guide to Methyl 2-chlorothiazole-5-carboxylate

Author: BenchChem Technical Support Team. **Date:** May 2026

Compound of Interest

Compound Name:	Methyl 2-chlorothiazole-5-carboxylate
CAS No.:	72605-86-8
Cat. No.:	B1315395

Get Quote

Abstract: This technical guide provides an in-depth analysis of the key spectroscopic data for **Methyl 2-chlorothiazole-5-carboxylate** (CAS No. 72605-86-8).[1][2] As a vital heterocyclic building block in medicinal chemistry and drug development, unambiguous structural confirmation is paramount.[3][4][5] This document serves as a reference for researchers and drug development professionals, detailing the expected ^1H NMR, ^{13}C NMR, Mass Spectrometry, and Infrared (IR) spectroscopy signatures of the title compound. The narrative emphasizes the causal relationships between molecular structure and spectral output, providing both field-proven insights and detailed experimental protocols for data acquisition.

Introduction and Molecular Structure

Methyl 2-chlorothiazole-5-carboxylate is a substituted thiazole derivative featuring a chlorine atom at the C2 position and a methyl ester group at the C5 position.[1][2] The electron-withdrawing nature of both the chloro and carboxylate substituents significantly influences the electronic environment of the thiazole ring, a key factor that is reflected across all spectroscopic methods. The primary objective of this guide is to synthesize predictive spectroscopic data with

robust interpretation, enabling researchers to confidently identify and characterize this compound.

For clarity in spectral assignments, the following standardized numbering scheme will be used throughout this guide.

Caption: Molecular structure of **Methyl 2-chlorothiazole-5-carboxylate**.

Proton Nuclear Magnetic Resonance (^1H NMR) Spectroscopy

^1H NMR spectroscopy provides crucial information about the electronic environment and connectivity of protons within a molecule. For **Methyl 2-chlorothiazole-5-carboxylate**, the spectrum is characteristically simple, containing two distinct signals.

Predicted ^1H NMR Data

The expected chemical shifts are summarized below. These values are predicted based on the analysis of similar thiazole structures and established chemical shift principles.[6]

Signal Assignment	Predicted Chemical Shift (δ , ppm)	Multiplicity	Integration
-OCH ₃ (Methyl Ester)	3.9 - 4.0	Singlet (s)	3H
H4 (Thiazole Ring)	8.2 - 8.4	Singlet (s)	1H

Interpretation and Rationale

The simplicity of the spectrum is a direct consequence of the molecule's structure, which lacks adjacent, non-equivalent protons that would lead to spin-spin coupling.

- Thiazole Proton (H4): The lone proton on the thiazole ring, H4, is expected to appear as a singlet significantly downfield (8.2 - 8.4 ppm). This pronounced deshielding is a cumulative effect. The inherent aromaticity of the thiazole ring places the proton in a region typical for heterocyclic systems.[7] Furthermore, the potent electron-withdrawing effects of the adjacent

ester group at C5 and the chloro group at C2 synergistically reduce the electron density around H4, shifting its resonance further downfield.

- Methyl Ester Protons (-OCH₃): The three protons of the methyl group are chemically equivalent and exhibit no coupling to other protons, resulting in a sharp singlet. Their expected chemical shift of ~3.9 ppm is characteristic of methyl esters, where the protons are deshielded by the adjacent oxygen atom.

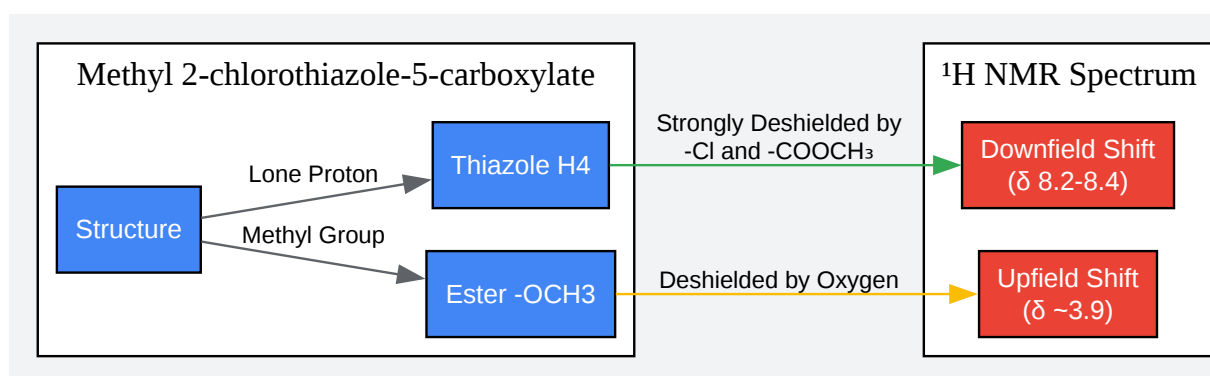

[Click to download full resolution via product page](#)

Caption: Rationale for ¹H NMR chemical shifts.

Experimental Protocol: ¹H NMR Spectroscopy

- Sample Preparation: Dissolve 5-10 mg of **Methyl 2-chlorothiazole-5-carboxylate** in ~0.6 mL of a deuterated solvent (e.g., CDCl₃ or DMSO-d₆). Ensure the sample is fully dissolved.
- Internal Standard: Add a small amount of tetramethylsilane (TMS) as an internal standard (δ = 0.00 ppm).
- Data Acquisition:
 - Transfer the solution to a 5 mm NMR tube.
 - Place the tube in a 400 MHz (or higher) NMR spectrometer.
 - Acquire the spectrum at room temperature. A standard single-pulse experiment is sufficient.

- Typically, 16-32 scans are adequate to achieve a good signal-to-noise ratio.
- Data Processing: Apply Fourier transformation, phase correction, and baseline correction to the acquired Free Induction Decay (FID). Calibrate the spectrum by setting the TMS peak to 0.00 ppm. Integrate the signals to confirm the proton ratios.

Carbon-13 Nuclear Magnetic Resonance (^{13}C NMR) Spectroscopy

^{13}C NMR spectroscopy is indispensable for mapping the carbon skeleton of a molecule. Each unique carbon environment produces a distinct signal, providing direct evidence for the key functional groups and the heterocyclic core.

Predicted ^{13}C NMR Data

Based on established ranges for thiazoles and esters, the following chemical shifts are predicted.^{[8][9]}

Carbon Assignment	Predicted Chemical Shift (δ , ppm)
-OCH ₃	52 - 55
C5	125 - 128
C4	145 - 148
C2	150 - 154
C=O (Ester)	160 - 163

Interpretation and Rationale

- Methyl Carbon (-OCH₃): This is the only sp³-hybridized carbon and therefore appears at the highest field (lowest ppm value), typically around 52-55 ppm.
- Ester Carbonyl (C=O): The carbonyl carbon of the ester is the most deshielded carbon in the molecule, appearing furthest downfield (160-163 ppm) due to the double bond to one oxygen and a single bond to another.

- Thiazole Ring Carbons (C2, C4, C5):
 - C2: This carbon is bonded to two heteroatoms (N and S) and a highly electronegative chlorine atom. This environment causes significant deshielding, placing its signal far downfield, predicted in the 150-154 ppm range.
 - C4: Bonded to the lone ring proton, this carbon's chemical shift is primarily influenced by the ring electronics. It is expected around 145-148 ppm.
 - C5: This carbon is attached to the ester group. While the carbonyl group is electron-withdrawing, the direct attachment is to another carbon, resulting in a less deshielded signal compared to C2 and C4. It is predicted to be the most upfield of the ring carbons, around 125-128 ppm.

Experimental Protocol: ^{13}C NMR Spectroscopy

- Sample Preparation: Prepare a more concentrated sample than for ^1H NMR. Dissolve 20-50 mg of the compound in ~0.6 mL of a deuterated solvent (e.g., CDCl_3 or DMSO-d_6).
- Data Acquisition:
 - Use a 5 mm NMR tube and a spectrometer with a carbon-observe probe (e.g., operating at 100 MHz for a 400 MHz ^1H instrument).
 - Run a standard proton-decoupled pulse sequence. This simplifies the spectrum by removing C-H coupling, resulting in a single sharp peak for each unique carbon.
 - A greater number of scans (e.g., 1024 or more) is typically required compared to ^1H NMR due to the low natural abundance of the ^{13}C isotope.
- Data Processing: Apply Fourier transformation and standard corrections. Reference the spectrum using the solvent peak (e.g., CDCl_3 at $\delta = 77.16$ ppm).

Mass Spectrometry (MS)

Mass spectrometry provides the molecular weight and valuable structural information based on the fragmentation pattern of the molecule upon ionization.

Predicted Mass Spectrometry Data

For Electron Ionization (EI) mass spectrometry:

m/z Value	Assignment	Rationale
177 / 179	$[M]^+ / [M+2]^+$	Molecular ion peak. The 3:1 ratio confirms the presence of one chlorine atom.
146 / 148	$[M - OCH_3]^+$	Loss of the methoxy radical from the ester.
118 / 120	$[M - COOCH_3]^+$	Loss of the entire carbomethoxy radical.
83	$[C_3HNS]^+$	Cleavage of the thiazole ring after loss of substituents.

Interpretation and Rationale

- **Molecular Ion ($[M]^+$):** The molecular ion peak is expected at m/z 177, corresponding to the molecular weight of the compound ($C_5H_4^{35}ClNO_2S$). A crucial confirmatory feature is the M+2 peak at m/z 179, which arises from the natural abundance of the ^{37}Cl isotope. The relative intensity of the M to M+2 peaks should be approximately 3:1, a definitive signature for a monochlorinated compound.
- **Fragmentation Pathway:** The primary fragmentation is expected to occur at the ester moiety, which is the most labile part of the molecule.
 - **Loss of $\cdot OCH_3$:** Cleavage of the O-CH₃ bond results in a stable acylium ion at m/z 146/148.
 - **Loss of $\cdot COOCH_3$:** Cleavage of the C5-C(O) bond leads to a fragment at m/z 118/120.

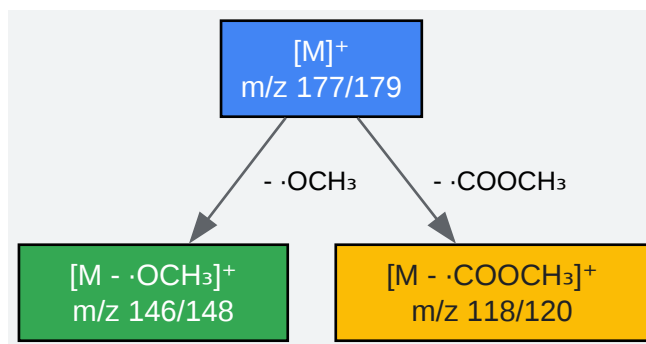

[Click to download full resolution via product page](#)

Caption: Predicted major fragmentation pathways in EI-MS.

Experimental Protocol: Mass Spectrometry

- **Sample Introduction:** Introduce a small quantity of the sample (typically <1 mg dissolved in a volatile solvent like methanol or dichloromethane) into the mass spectrometer, often via a direct insertion probe or GC inlet.
- **Ionization:** Utilize Electron Ionization (EI) at a standard energy of 70 eV. This energy level is sufficient to cause reproducible fragmentation.
- **Analysis:** The generated ions are separated by a mass analyzer (e.g., quadrupole or time-of-flight) based on their mass-to-charge ratio (m/z).
- **Detection:** A detector records the abundance of each ion, generating the mass spectrum.

Infrared (IR) Spectroscopy

IR spectroscopy is a rapid and effective method for identifying the functional groups present in a molecule by measuring the absorption of infrared radiation at specific vibrational frequencies.

Predicted IR Absorption Bands

Wavenumber (cm ⁻¹)	Vibration Type	Functional Group
~3100	C-H Stretch	Aromatic (Thiazole C4-H)
2950-2990	C-H Stretch	Aliphatic (-OCH ₃)
~1725	C=O Stretch	Ester Carbonyl
1550-1600	C=N / C=C Stretch	Thiazole Ring
1200-1300	C-O Stretch	Ester (Asymmetric)
700-800	C-Cl Stretch	Chloroalkene

Interpretation and Rationale

The IR spectrum provides a clear fingerprint of the molecule's key structural features.

- **Carbonyl Stretch (C=O):** The most prominent and diagnostically useful peak will be the strong, sharp absorption band around 1725 cm⁻¹. This is characteristic of the C=O stretching vibration in an α,β -unsaturated ester. The conjugation with the thiazole ring slightly lowers the frequency from that of a saturated ester.
- **Thiazole Ring Vibrations:** The stretching vibrations of the C=N and C=C bonds within the aromatic ring typically appear in the 1550-1600 cm⁻¹ region.
- **C-O and C-Cl Stretches:** A strong band corresponding to the ester C-O stretch should be visible in the 1200-1300 cm⁻¹ region. The C-Cl stretch appears at lower frequencies, typically in the fingerprint region between 700-800 cm⁻¹.
- **C-H Stretches:** The weak absorption above 3000 cm⁻¹ (~3100 cm⁻¹) is indicative of the sp² C-H bond on the thiazole ring, while the absorptions just below 3000 cm⁻¹ are due to the sp³ C-H bonds of the methyl group.

Experimental Protocol: IR Spectroscopy (ATR)

- **Instrument Preparation:** Ensure the Attenuated Total Reflectance (ATR) crystal (e.g., diamond or germanium) is clean. Record a background spectrum of the empty crystal.

- **Sample Application:** Place a small amount of the solid **Methyl 2-chlorothiazole-5-carboxylate** powder directly onto the ATR crystal.
- **Data Acquisition:** Apply pressure using the ATR anvil to ensure good contact between the sample and the crystal.
- **Spectrum Collection:** Collect the sample spectrum. Typically, 16-32 scans are co-added to produce a spectrum with a high signal-to-noise ratio over a range of 4000-400 cm^{-1} . The instrument software automatically ratios the sample scan against the background scan to produce the final absorbance or transmittance spectrum.

Conclusion

The structural elucidation of **Methyl 2-chlorothiazole-5-carboxylate** is reliably achieved through a combination of modern spectroscopic techniques. ^1H and ^{13}C NMR define the precise proton and carbon environments, mass spectrometry confirms the molecular weight and the presence of chlorine while revealing fragmentation patterns, and IR spectroscopy provides a rapid confirmation of essential functional groups. The collective data presented in this guide—a sharp singlet around 8.3 ppm in the ^1H NMR, a carbonyl carbon signal above 160 ppm in the ^{13}C NMR, a distinct M/M+2 isotopic pattern at m/z 177/179 in the mass spectrum, and a strong C=O absorption near 1725 cm^{-1} in the IR spectrum—provide a robust and self-validating analytical signature for this important chemical intermediate.

References

- MDPI. Design and Synthesis of Novel 1,3-Thiazole and 2-Hydrazinyl-1,3-Thiazole Derivatives as Anti-Candida Agents. [[Link](#)]
- University of Wisconsin. ^{13}C NMR Chemical Shifts. [[Link](#)]
- PubMed. Development of Thiazole-5-carboxylate Derivatives as Selective Inhibitors of Monoacylglycerol Lipase as Target in Cancer. [[Link](#)]
- Semantic Scholar. A new and efficient preparation of 2-aminothiazole-5-carbamides: applications to the synthesis of the anti-cancer drug dasatinib. [[Link](#)]
- University of Wisconsin. ^1H NMR Chemical Shifts. [[Link](#)]

- Spectroscopy Online. The Carbonyl Group, Part V: Carboxylates—Coming Clean. [[Link](#)]
- Chemistry LibreTexts. Interpreting C-13 NMR Spectra. [[Link](#)]

Need Custom Synthesis?

BenchChem offers custom synthesis for rare earth carbides and specific isotopic labeling.

Email: info@benchchem.com or [Request Quote Online](#).

Sources

- 1. buildingblock.bocsci.com [buildingblock.bocsci.com]
- 2. Methyl 2-chlorothiazole-5-carboxylate | CymitQuimica [cymitquimica.com]
- 3. [Development of Thiazole-5-carboxylate Derivatives as Selective Inhibitors of Monoacylglycerol Lipase as Target in Cancer - PubMed](https://pubmed.ncbi.nlm.nih.gov/) [pubmed.ncbi.nlm.nih.gov]
- 4. chemimpex.com [chemimpex.com]
- 5. pdfs.semanticscholar.org [pdfs.semanticscholar.org]
- 6. organicchemistrydata.org [organicchemistrydata.org]
- 7. mdpi.com [mdpi.com]
- 8. organicchemistrydata.org [organicchemistrydata.org]
- 9. chem.libretexts.org [chem.libretexts.org]
- To cite this document: BenchChem. [A Comprehensive Spectroscopic Guide to Methyl 2-chlorothiazole-5-carboxylate]. BenchChem, [2026]. [Online PDF]. Available at: [<https://www.benchchem.com/product/b1315395/docs#a-comprehensive-spectroscopic-guide-to-methyl-2-chlorothiazole-5-carboxylate>]

Disclaimer & Data Validity:

The information provided in this document is for Research Use Only (RUO) and is strictly not intended for diagnostic or therapeutic procedures. While BenchChem strives to provide accurate protocols, we make no warranties, express or implied, regarding the fitness of this product for every specific experimental setup.

Technical Support: The protocols provided are for reference purposes. Unsure if this reagent suits your experiment?

Need Industrial/Bulk Grade? [Request Custom Synthesis Quote](#)

BenchChem

Our mission is to be the trusted global source of essential and advanced chemicals, empowering scientists and researchers to drive progress in science and industry.

Contact

Address: 3281 E Guasti Rd
Ontario, CA 91761, United States
Phone: (601) 213-4426
Email: info@benchchem.com

[Contact our Ph.D. Support Team for a compatibility check](#)