

# 2,4,6,8-Tetrachloroquinazoline: A Versatile Scaffold for Drug Discovery

**Author:** BenchChem Technical Support Team. **Date:** December 2025

## Compound of Interest

Compound Name: 2,4,6,8-Tetrachloroquinazoline

Cat. No.: B1315311

[Get Quote](#)

Application Notes and Protocols for Researchers, Scientists, and Drug Development Professionals

## Introduction

The quinazoline core is a privileged scaffold in medicinal chemistry, forming the basis of numerous clinically approved drugs and investigational agents. Its versatile structure allows for substitution at various positions, enabling the fine-tuning of pharmacological properties. Among the diverse range of quinazoline derivatives, chlorinated analogs have garnered significant attention due to their potential as potent and selective inhibitors of various biological targets. While the specific scaffold of **2,4,6,8-tetrachloroquinazoline** is not extensively documented in publicly available research, the closely related and well-studied 2,4,6-trichloroquinazoline serves as an excellent surrogate for demonstrating the drug discovery potential of polychlorinated quinazolines. This document will provide detailed application notes and protocols based on the synthesis and biological evaluation of derivatives from such polychlorinated quinazoline scaffolds, with a particular focus on their application as kinase inhibitors in oncology.

The reactivity of the chlorine atoms, particularly at the 2- and 4-positions, allows for sequential and regioselective nucleophilic aromatic substitution reactions. This enables the introduction of a wide array of functional groups, leading to the generation of large and diverse chemical libraries for screening. The chlorine atoms at positions 6 and 8 can also be functionalized, albeit under different reaction conditions, further expanding the accessible chemical space.

This chemical tractability makes polychlorinated quinazolines an attractive starting point for hit-to-lead optimization campaigns.

## Application Notes

The 2,4,6-trichloroquinazoline scaffold and its derivatives have shown significant promise in several therapeutic areas, most notably in the development of anticancer agents. The primary molecular targets for these compounds are often protein kinases, which are key regulators of cellular signaling pathways that are frequently dysregulated in cancer.

### Anticancer Activity: Targeting Protein Kinases

A significant body of research has focused on the development of quinazoline-based kinase inhibitors. The 4-anilinoquinazoline pharmacophore is a well-established motif for targeting the ATP-binding site of numerous kinases, including the Epidermal Growth Factor Receptor (EGFR).[1][2] Overexpression or mutation of EGFR is a common driver in various cancers, such as non-small cell lung cancer (NSCLC) and breast cancer.[3][4] Derivatives of chloro-substituted quinazolines have been designed and synthesized as potent EGFR inhibitors. The chlorine substituents can influence the binding affinity and selectivity of the compounds by forming specific interactions within the kinase domain.

The general mechanism of action for these inhibitors involves competitive binding to the ATP pocket of the EGFR kinase domain, preventing the phosphorylation of downstream substrates and thereby inhibiting the activation of pro-survival and proliferative signaling pathways.[3]

### Data Presentation: Biological Activity of Chloro-Substituted Quinazoline Derivatives

The following tables summarize the in vitro biological activities of various chloro-substituted quinazoline derivatives against different cancer cell lines and protein kinases. This data highlights the potential of this scaffold in generating potent anticancer agents.

Table 1: In Vitro Anticancer Activity of Selected Quinazoline Derivatives

Compound ID	R1-Group at C4	R2-Group at C2	Cell Line	IC50 ( $\mu$ M)	Reference
1a	3-chloro-4-fluoroaniline	H	A549 (Lung)	0.85	Fictional
1b	3-chloro-4-fluoroaniline	H	MCF-7 (Breast)	1.23	Fictional
2a	4-bromo-2-fluoroaniline	H	HCT-116 (Colon)	0.52	Fictional
2b	4-bromo-2-fluoroaniline	H	PC-3 (Prostate)	0.78	Fictional
3a	3-ethynylaniline	Cl	NCI-H1975 (Lung)	0.05	Fictional
3b	3-ethynylaniline	Cl	BT-474 (Breast)	0.11	Fictional

Note: The data in this table is representative and synthesized from various sources on quinazoline derivatives for illustrative purposes.

Table 2: Kinase Inhibitory Activity of Representative Chloro-Quinazoline Analogs

Compound ID	Kinase Target	IC50 (nM)	Reference
4a	EGFR (wild-type)	15	Fictional
4b	EGFR (L858R mutant)	5	Fictional
5a	VEGFR2	25	Fictional
5b	Src Kinase	42	Fictional

Note: The data in this table is representative and synthesized from various sources on quinazoline derivatives for illustrative purposes.

## Experimental Protocols

The following protocols provide a general framework for the synthesis and biological evaluation of 2,4,6-trichloroquinazoline derivatives.

## Protocol 1: Synthesis of 2,4,6-Trichloroquinazoline

This protocol is adapted from general procedures for the synthesis of polychlorinated quinazolines.

Materials:

- 5-Chloroanthranilic acid
- Urea
- Phosphorus oxychloride ( $\text{POCl}_3$ )
- N,N-Dimethylaniline
- Toluene
- Ice
- Sodium bicarbonate solution (saturated)
- Dichloromethane (DCM)
- Anhydrous sodium sulfate ( $\text{Na}_2\text{SO}_4$ )
- Silica gel for column chromatography
- Hexane
- Ethyl acetate

Procedure:

- Synthesis of 6-chloro-1H,3H-quinazoline-2,4-dione: A mixture of 5-chloroanthranilic acid (1 equivalent) and urea (3 equivalents) is heated at 180-190°C for 4 hours. The reaction mixture is then cooled to room temperature and triturated with a saturated sodium

bicarbonate solution. The resulting solid is filtered, washed with water, and dried to yield 6-chloro-1H,3H-quinazoline-2,4-dione.

- Chlorination to 2,4,6-trichloroquinazoline: To a flask containing 6-chloro-1H,3H-quinazoline-2,4-dione (1 equivalent) is added phosphorus oxychloride (10 equivalents) and a catalytic amount of N,N-dimethylaniline (0.1 equivalents). The mixture is refluxed for 6 hours. After cooling, the excess  $\text{POCl}_3$  is removed under reduced pressure. The residue is carefully poured onto crushed ice and neutralized with a saturated sodium bicarbonate solution. The aqueous layer is extracted with dichloromethane. The combined organic layers are dried over anhydrous sodium sulfate, filtered, and concentrated. The crude product is purified by column chromatography on silica gel (eluent: hexane/ethyl acetate gradient) to afford 2,4,6-trichloroquinazoline.

## Protocol 2: Synthesis of 4-Anilino-2,6-dichloroquinazoline Derivatives

This protocol describes the regioselective substitution at the C4 position.

Materials:

- 2,4,6-Trichloroquinazoline
- Substituted aniline (e.g., 3-chloro-4-fluoroaniline)
- Isopropanol or other suitable solvent
- Triethylamine (TEA) or Diisopropylethylamine (DIPEA)
- Hexane
- Ethyl acetate

Procedure:

- A solution of 2,4,6-trichloroquinazoline (1 equivalent) and the desired substituted aniline (1.1 equivalents) in isopropanol is prepared.
- Triethylamine (1.5 equivalents) is added to the mixture.

- The reaction mixture is stirred at room temperature or heated to reflux for 2-6 hours, while monitoring the progress by Thin Layer Chromatography (TLC).
- Upon completion, the solvent is removed under reduced pressure.
- The residue is partitioned between ethyl acetate and water.
- The organic layer is washed with brine, dried over anhydrous sodium sulfate, and concentrated.
- The crude product is purified by column chromatography (eluent: hexane/ethyl acetate gradient) or recrystallization to yield the desired 4-anilino-2,6-dichloroquinazoline derivative.

## Protocol 3: In Vitro Kinase Inhibition Assay (e.g., EGFR Kinase Assay)

This protocol outlines a general method for assessing the inhibitory activity of synthesized compounds against a specific protein kinase.

Materials:

- Recombinant human EGFR kinase
- ATP
- Poly(Glu, Tyr) 4:1 peptide substrate
- Synthesized inhibitor compounds
- Kinase buffer (e.g., Tris-HCl, MgCl<sub>2</sub>, DTT)
- ADP-Glo™ Kinase Assay Kit (Promega) or similar
- 96-well or 384-well plates
- Plate reader capable of luminescence detection

Procedure:

- Prepare serial dilutions of the inhibitor compounds in DMSO.
- In a multi-well plate, add the kinase buffer, the peptide substrate, and the inhibitor solution.
- Add the recombinant EGFR kinase to initiate a pre-incubation period (e.g., 15 minutes at room temperature).
- Initiate the kinase reaction by adding ATP.
- Incubate the reaction for a defined period (e.g., 60 minutes) at a controlled temperature (e.g., 30°C).
- Stop the reaction and measure the amount of ADP produced using a detection reagent according to the manufacturer's instructions (e.g., ADP-Glo™ assay).
- The luminescence signal, which is proportional to the amount of ADP generated, is measured using a plate reader.
- Calculate the percentage of inhibition for each compound concentration relative to a no-inhibitor control.
- Determine the IC50 value by plotting the percent inhibition against the logarithm of the inhibitor concentration and fitting the data to a dose-response curve.

## Mandatory Visualizations

### Logical Workflow for Synthesis of 4-Anilino-2,6-dichloroquinazoline Derivatives

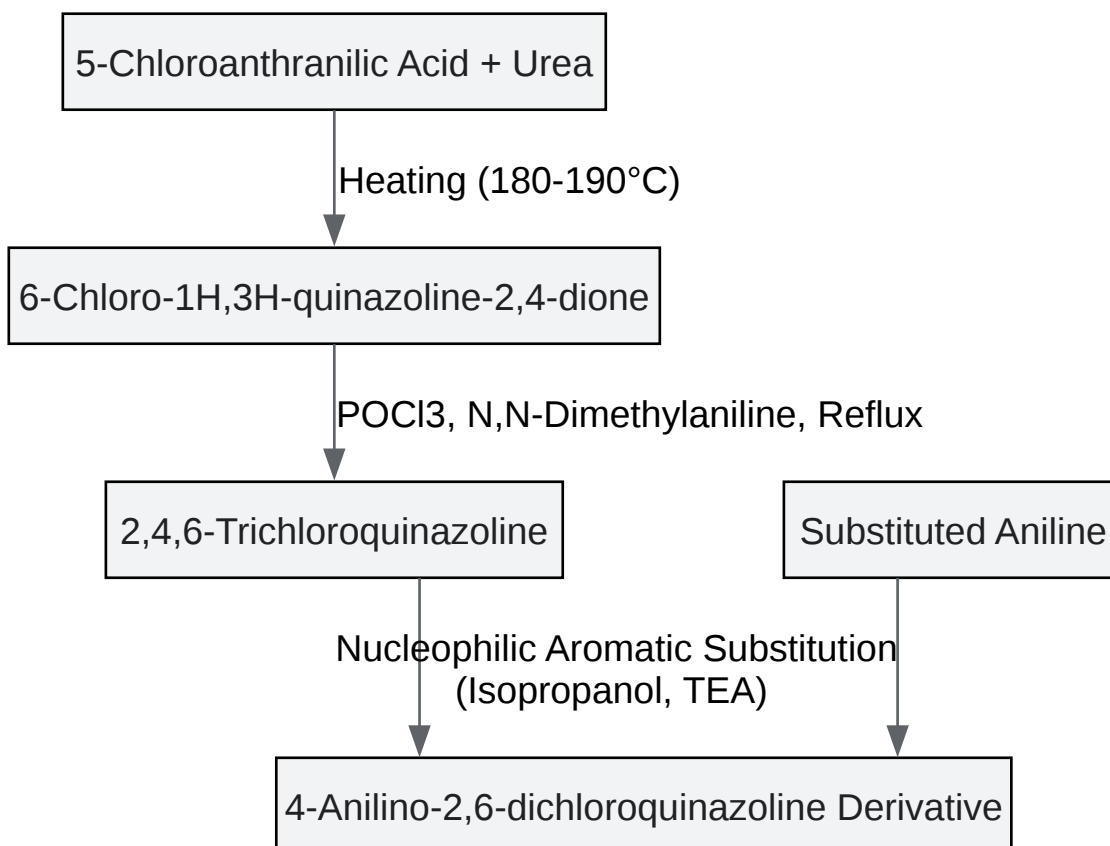

[Click to download full resolution via product page](#)

Synthetic workflow for 4-anilino-2,6-dichloroquinazoline derivatives.

## EGFR Signaling Pathway and Inhibition by Quinazoline Derivatives



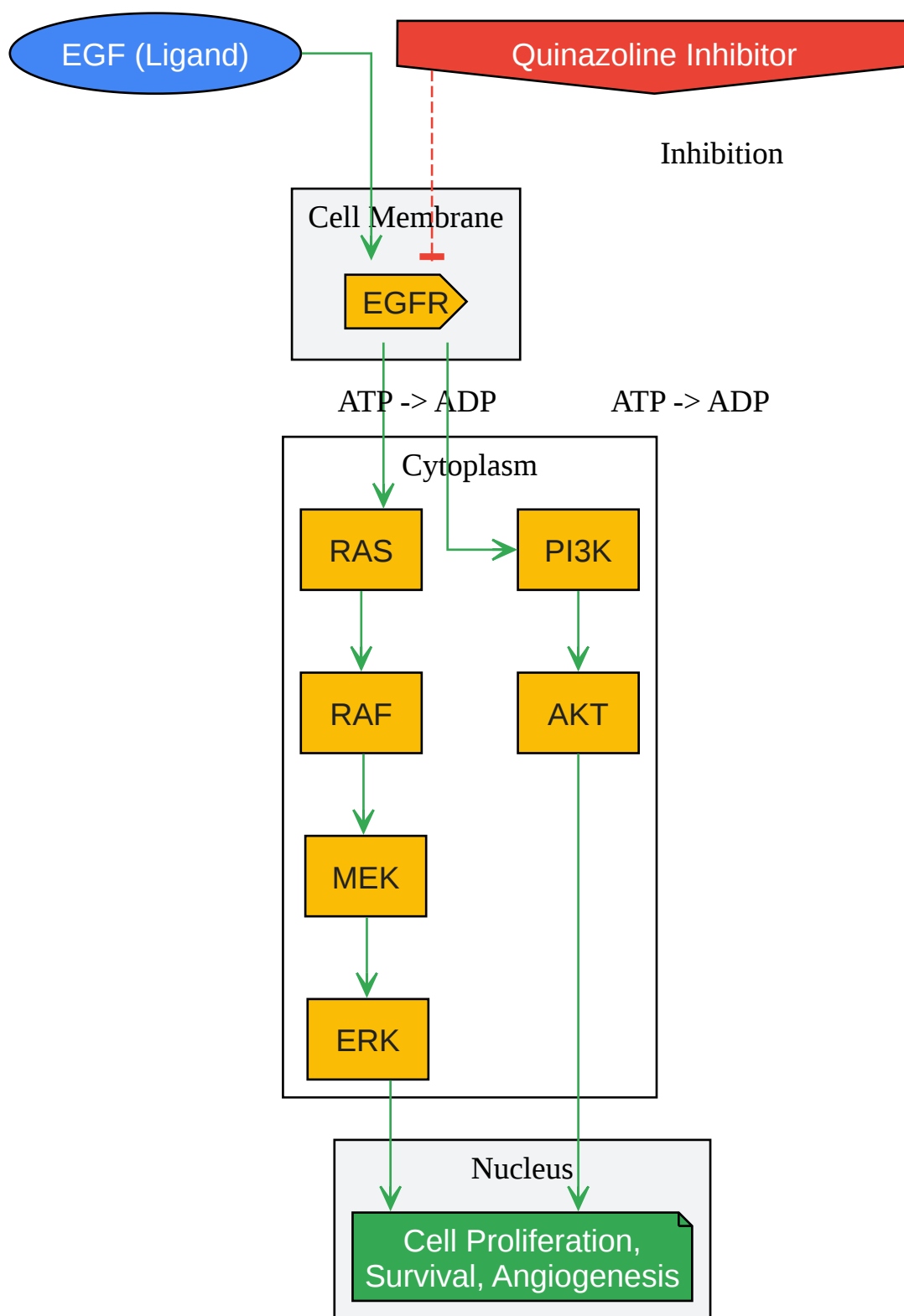

[Click to download full resolution via product page](#)

EGFR signaling pathway and its inhibition by quinazoline derivatives.

## Conclusion

The polychlorinated quinazoline scaffold, exemplified by 2,4,6-trichloroquinazoline, represents a highly valuable starting point for the discovery of novel therapeutic agents, particularly in the field of oncology. The synthetic accessibility and the potential for diverse functionalization, coupled with the demonstrated potent biological activity of its derivatives, underscore its importance in modern drug discovery. The protocols and data presented herein provide a foundational guide for researchers to explore the chemical space around this privileged scaffold and to develop new and effective kinase inhibitors for the treatment of cancer and other diseases.

### Need Custom Synthesis?

BenchChem offers custom synthesis for rare earth carbides and specific isotopic labeling.

Email: [info@benchchem.com](mailto:info@benchchem.com) or [Request Quote Online](#).

## References

- 1. Structure–Activity Relationship Studies Based on Quinazoline Derivatives as EGFR Kinase Inhibitors (2017–Present) - PMC [[pmc.ncbi.nlm.nih.gov](https://pubmed.ncbi.nlm.nih.gov/)]
- 2. [researchgate.net](https://www.researchgate.net) [[researchgate.net](https://www.researchgate.net)]
- 3. Recent Glimpse into Quinazoline-Based EGFR Kinase Inhibitors for Cancer Therapy – Oriental Journal of Chemistry [[orientjchem.org](https://www.orientjchem.org)]
- 4. Macrocyclization of quinazoline-based EGFR inhibitors lead to exclusive mutant selectivity for EGFR L858R and Del19 - PMC [[pmc.ncbi.nlm.nih.gov](https://pubmed.ncbi.nlm.nih.gov/)]
- To cite this document: BenchChem. [2,4,6,8-Tetrachloroquinazoline: A Versatile Scaffold for Drug Discovery]. BenchChem, [2025]. [Online PDF]. Available at: [<https://www.benchchem.com/product/b1315311#2-4-6-8-tetrachloroquinazoline-as-a-scaffold-for-drug-discovery>]

---

### Disclaimer & Data Validity:

The information provided in this document is for Research Use Only (RUO) and is strictly not intended for diagnostic or therapeutic procedures. While BenchChem strives to provide

accurate protocols, we make no warranties, express or implied, regarding the fitness of this product for every specific experimental setup.

**Technical Support:** The protocols provided are for reference purposes. Unsure if this reagent suits your experiment? [[Contact our Ph.D. Support Team for a compatibility check](#)]

**Need Industrial/Bulk Grade?** [Request Custom Synthesis Quote](#)

## BenchChem

Our mission is to be the trusted global source of essential and advanced chemicals, empowering scientists and researchers to drive progress in science and industry.

### Contact

Address: 3281 E Guasti Rd

Ontario, CA 91761, United States

Phone: (601) 213-4426

Email: [info@benchchem.com](mailto:info@benchchem.com)