

Technical Application Note: High-Purity Synthesis of $[RuCl_5(NH_3)]$ via the Hydrazine Reduction Route

Author: BenchChem Technical Support Team. **Date:** May 2026

Compound of Interest

Compound Name: *Pentaamminechlororuthenium(III) chloride*

Cat. No.: *B13142355*

[Get Quote](#)

Strategic Rationale & Mechanism

The synthesis of Ruthenium(III) ammine complexes is historically plagued by the formation of mixed species (e.g.,

), $[RuCl_4(NH_3)]$, and $[RuCl_3(NH_3)_2]$. The direct reaction of

with ammonia often yields intractable mixtures.

This protocol utilizes Hydrazine Hydrate (

) as a dual-purpose reagent:

- Reductant: It reduces

to

$[RuCl_4(NH_3)]$, which is kinetically more labile, facilitating the substitution of chloride ligands by ammonia.

- Ligand Source: It provides the dinitrogen () ligand via dehydrogenation, forming the stable intermediate Pentaamminedinitrogenruthenium(II) ().

This intermediate is the "purity gate." Only the pentaamine species forms the stable dinitrogen complex, allowing impurities to be washed away before the final conversion back to the target

species using HCl.

Reaction Pathway (DOT Visualization)

The following diagram illustrates the oxidation state changes and ligand substitutions.

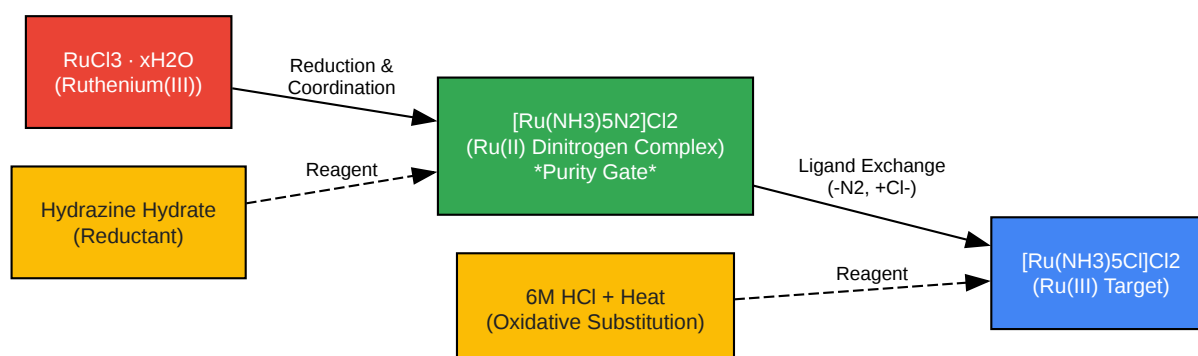

[Click to download full resolution via product page](#)

Figure 1: Synthetic pathway showing the reduction of Ru(III) to the Ru(II)-dinitrogen intermediate, followed by oxidative substitution to the final Ru(III) product.

Safety Profile (Critical)

This protocol involves Hydrazine Hydrate, a highly toxic, carcinogenic, and corrosive agent. Strict adherence to safety standards is non-negotiable.

Hazard	Description	Mitigation Protocol
Hydrazine Hydrate	Carcinogen, Corrosive, Skin Sensitizer.	Use double nitrile gloves. Work exclusively in a fume hood. Neutralize spills immediately with dilute hypochlorite (bleach).
Ruthenium(III) Chloride	Corrosive, Hygroscopic.	Avoid metal spatulas (use glass/Teflon). Store in desiccator.
Ammonia Gas	Respiratory Irritant.	Generated during reaction. Ensure hood airflow >100 fpm.
RuO ₄ Formation	Highly Toxic Volatile Oxide.	NEVER mix Ruthenium residues with strong oxidants (e.g., concentrated HNO ₃) without specific protocols.

Experimental Protocol

Materials Required[1][2][3][4][5][6][7][8]

- Precursor: Ruthenium(III) chloride hydrate () (Commercial grade, usually ~40-43% Ru).
- Reagents: Hydrazine hydrate (98-100%), Concentrated Ammonium Hydroxide (28-30%), Hydrochloric Acid (12M and 6M).
- Solvents: Distilled water, Ethanol, Acetone.
- Equipment: 3-neck round bottom flask, reflux condenser, addition funnel, ice bath, sintered glass filter (medium porosity).

Step 1: Synthesis of the Intermediate

This step isolates the pentaammine framework in the Ru(II) state.

- Dissolution: In a 3-neck flask, dissolve 1.0 g of
in 10 mL of water.
- Ammonolysis: Slowly add 10 mL of concentrated
. The solution will darken.
- Hydrazine Addition (Critical): Cool the flask in an ice bath. With vigorous stirring, add 10 mL of Hydrazine Hydrate dropwise over 15 minutes.
 - Observation: The reaction is exothermic and evolves gas (
). The solution will turn from dark brown to a turbid, pale yellow/orange.
- Digestion: Allow the mixture to stand at room temperature for 12 hours (or overnight).
 - Result: A heavy precipitate of
(pale yellow/cream) will form.
- Filtration: Filter the solid using a sintered glass funnel. Wash with small amounts of cold water, then ethanol, then acetone.
 - Note: This intermediate is relatively stable in air but should be used promptly for Step 2 to ensure maximum yield.

Step 2: Conversion to

This step oxidizes Ru(II) back to Ru(III) and replaces the
ligand with chloride.

- Resuspension: Transfer the solid intermediate from Step 1 into a flask containing 30 mL of 6M HCl.
- Reflux: Heat the mixture to reflux.
 - Mechanism:[1][2] Vigorous evolution of

gas will occur as the dinitrogen ligand is displaced. The solution will darken as Ru(II) oxidizes to Ru(III).

- Completion: Continue boiling for 15–20 minutes until gas evolution ceases and the solution becomes a clear, deep yellow-orange color.
- Crystallization: Cool the solution slowly to room temperature, then place in an ice bath. Bright yellow-orange crystals of

will precipitate.
- Purification: Filter the crystals. Wash with 0.1M HCl (to prevent hydrolysis), followed by ethanol and acetone. Dry in a vacuum desiccator.

Quality Control & Validation

To ensure the protocol yielded the correct isomer, perform the following validation checks.

A. Visual Inspection^[3]^[10]^[11]

- Correct: Bright yellow to orange-yellow crystalline powder.
- Incorrect:
 - Black/Grey: Metallic Ruthenium (Hydrazine added too fast or too hot).
 - Colorless/White:

(Over-amination or failure to substitute Cl).
 - Purple/Red:^[1] Possible formation of Ruthenium Red (multinuclear oxo-bridged species).

B. UV-Vis Spectroscopy (Self-Validating Metric)

Dissolve a small sample in dilute HCl (pH 2-3 to suppress hydrolysis).

Feature	Expected Value	Interpretation
	328 nm	Characteristic Ligand-to-Metal Charge Transfer (LMCT) band for .
(Extinction)	~1,900 - 2,100	High intensity confirms purity. Low intensity suggests mixed ammines.
Secondary Band	~260 nm	Often observed; assigned to internal ligand transitions or higher energy CT.

C. Infrared Spectroscopy (FT-IR)

- Ru-N Stretch: Strong band at ~480-500
.
- N-H Stretch: Broad bands at 3100-3300
.
- Absence of
: Ensure no strong peak at ~2100
(which would indicate unreacted intermediate).

References

- Allen, A. D., & Senoff, C. V. (1965). Nitrogenopentammineruthenium(II) complexes.[3]
Chemical Communications, 621.[3]
 - Source:[Link][3]

- Vogt, L. H., et al. (1970). Chloropentaammineruthenium(III) Chloride. Inorganic Syntheses, Volume 12, pp. 2-5. McGraw-Hill.[4]
 - Source:[[Link](#)]
- Ford, P. C. (1970). Properties of the pentaamminechlororuthenium(III) ion. Inorganic Chemistry, 9(6).
 - Source:[[Link](#)]

Need Custom Synthesis?

BenchChem offers custom synthesis for rare earth carbides and specific isotopic labeling.

Email: info@benchchem.com or [Request Quote Online](#).

Sources

- 1. UV-Vis spectra for $[\text{Co}(\text{NH}_3)_5\text{Cl}]\text{Cl}_2$: Use the color | Chegg.com [[chegg.com](https://www.chegg.com)]
- 2. sites.lsa.umich.edu [sites.lsa.umich.edu]
- 3. Nitrogenopentammineruthenium(II) complexes - Chemical Communications (London) (RSC Publishing) [pubs.rsc.org]
- 4. sites.lsa.umich.edu [sites.lsa.umich.edu]
- To cite this document: BenchChem. [Technical Application Note: High-Purity Synthesis of via the Hydrazine Reduction Route]. BenchChem, [2026]. [Online PDF]. Available at: [<https://www.benchchem.com/product/b13142355/docs#technical-application-note-high-purity-synthesis-of-via-the-hydrazine-reduction-route>]

Disclaimer & Data Validity:

The information provided in this document is for Research Use Only (RUO) and is strictly not intended for diagnostic or therapeutic procedures. While BenchChem strives to provide accurate protocols, we make no warranties, express or implied, regarding the fitness of this product for every specific experimental setup.

Technical Support: The protocols provided are for reference purposes. Unsure if this reagent suits your experiment?

Need Industrial/Bulk Grade? [Request Custom Synthesis Quote](#)

BenchChem

Our mission is to be the trusted global source of essential and advanced chemicals, empowering scientists and researchers to drive progress in science and industry.

Contact

Address: 3281 E Guasti Rd
Ontario, CA 91761, United States
Phone: (601) 213-4426
Email: info@benchchem.com

[Contact our Ph.D. Support Team for a compatibility check](#)