

# Technical Support Center: Troubleshooting Low Reactivity of Pyrimidine Derivatives

**Author:** BenchChem Technical Support Team. **Date:** May 2026

## Compound of Interest

Compound Name: *5-Phenylpyrimidine-2-carbonylchloride*

Cat. No.: *B13140464*

[Get Quote](#)

Welcome to the Technical Support Center for researchers, scientists, and drug development professionals. This guide is designed to provide in-depth troubleshooting strategies and address frequently asked questions regarding the low reactivity of pyrimidine derivatives in organic synthesis. Pyrimidine scaffolds are cornerstones in medicinal chemistry and materials science; however, their inherent electronic properties can often lead to challenging synthetic transformations. This guide offers practical, field-proven insights to overcome these hurdles.

## Understanding the Challenge: The Electron-Deficient Nature of Pyrimidines

The pyrimidine ring, a six-membered heterocycle with two nitrogen atoms at the 1 and 3 positions, is electronically analogous to a deactivated benzene ring. The electronegative nitrogen atoms withdraw electron density from the carbon atoms, making the ring  $\pi$ -deficient. This electronic characteristic is the primary reason for the low reactivity of pyrimidines in many common synthetic reactions, particularly those involving electrophilic aromatic substitution. However, this same property makes the pyrimidine ring susceptible to nucleophilic attack, a feature that can be exploited with the right strategies.

## Diagram: Electron Density Distribution in the Pyrimidine Ring

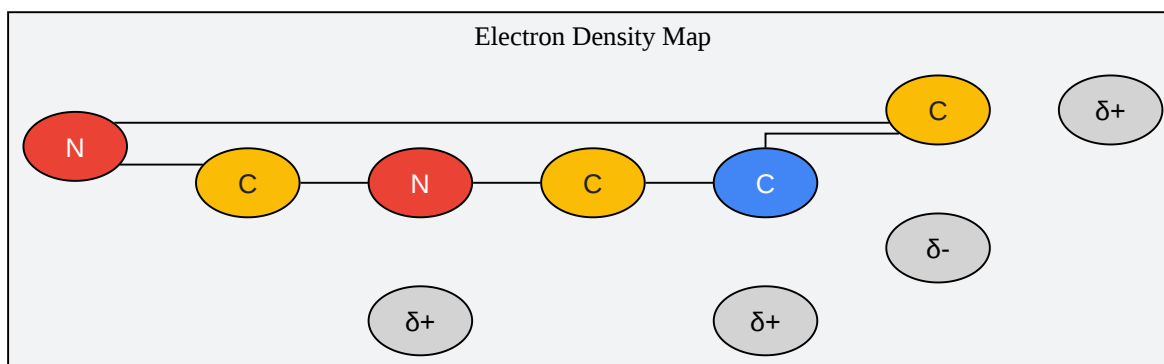

[Click to download full resolution via product page](#)

Caption: Electron density distribution in the pyrimidine ring.

## Frequently Asked Questions (FAQs)

Q1: Why is my Suzuki-Miyaura coupling with a chloropyrimidine failing or giving low yields?

Chloropyrimidines are notoriously less reactive in Suzuki-Miyaura couplings compared to their bromo or iodo counterparts due to the stronger C-Cl bond, which makes the oxidative addition step of the catalytic cycle more difficult.<sup>[1][2]</sup> Several factors could be contributing to the low yield:

- **Inactive Catalyst:** The active Pd(0) species may not be forming efficiently from the Pd(II) precatalyst.
- **Poor Ligand Choice:** The ligand may not be sufficiently electron-rich or bulky to promote oxidative addition.
- **Inappropriate Base or Solvent:** The base may not be strong enough to facilitate the transmetalation step, or the solvent may not be optimal for the solubility of the reactants and

catalyst.

- Protodeboronation of Boronic Acid: The boronic acid can be unstable under the reaction conditions and degrade before coupling.[3]

Q2: I'm observing a mixture of isomers in the nucleophilic aromatic substitution (S<sub>N</sub>A<sub>r</sub>) of my dichloropyrimidine. How can I improve regioselectivity?

The regioselectivity of S<sub>N</sub>A<sub>r</sub> reactions on dichloropyrimidines is highly sensitive to the electronic and steric environment of the ring, as well as the reaction conditions.[4][5] Generally, the C4 position is more reactive than the C2 position. However, substituents on the ring can alter this preference.

- Electronic Effects: Electron-donating groups at the C6 position can surprisingly favor substitution at the C2 position.[4]
- Steric Hindrance: Bulky groups at the C5 position can hinder attack at the C4 position, favoring C2 substitution.
- Solvent and Base: The choice of solvent and base can significantly influence the regioselectivity. For instance, using LiHMDS as a base in THF has been shown to dramatically improve C4 selectivity in some cases.[5]

Q3: My C-H activation/functionalization reaction on a pyrimidine derivative is not working. What are the common pitfalls?

Direct C-H functionalization of pyrimidines is a powerful tool but can be challenging due to the electron-deficient nature of the ring, which makes C-H bond activation difficult.[6]

- Catalyst Inhibition: The nitrogen atoms in the pyrimidine ring can coordinate to the metal catalyst and inhibit its activity.
- Incorrect Oxidant or Additives: The choice of oxidant is crucial for regenerating the active catalyst.
- Low Reactivity of the C-H bond: Pyrimidine C-H bonds are generally less reactive than those in more electron-rich heterocycles.

## Troubleshooting Guides

### Guide 1: Improving Low Yields in Suzuki-Miyaura Coupling of Chloropyrimidines

If you are experiencing low to no yield in a Suzuki coupling with a chloropyrimidine, a systematic approach to optimizing the reaction conditions is necessary.

Step-by-Step Troubleshooting Protocol:

- **Catalyst and Ligand Screening:** The choice of catalyst and ligand is the most critical factor. For unreactive aryl chlorides, more active catalytic systems are required.
  - **Initial Recommendation:** Start with a robust catalyst system like Pd(PPh<sub>3</sub>)<sub>4</sub> or a combination of a palladium precursor (e.g., Pd<sub>2</sub>(dba)<sub>3</sub>) and a bulky, electron-rich phosphine ligand (e.g., XPhos, SPhos).<sup>[7]</sup>
  - **If the reaction is still sluggish:** Switch to a more active pre-catalyst like a Buchwald G3 or G4 palladacycle, or an N-heterocyclic carbene (NHC)-based catalyst like PEPPSI-IPr.<sup>[1]</sup>
- **Base and Solvent Optimization:**
  - **Base:** Stronger bases are often required. If K<sub>2</sub>CO<sub>3</sub> or Cs<sub>2</sub>CO<sub>3</sub> are ineffective, try K<sub>3</sub>PO<sub>4</sub>.<sup>[1]</sup>
  - **Solvent:** Aprotic polar solvents like 1,4-dioxane or DMF are common choices. A mixture of solvents, such as toluene/ethanol/water, can sometimes improve solubility and reactivity.<sup>[8]</sup>
- **Temperature and Reaction Time:**
  - **Increase the reaction temperature.** Microwave irradiation can dramatically reduce reaction times and improve yields.<sup>[9]</sup>
- **Boronic Acid Stability:**
  - **Use fresh, high-quality boronic acid.**

- Consider converting the boronic acid to a more stable boronate ester (e.g., a pinacol ester) to prevent protodeboronation.[10]

Data Presentation: Comparison of Palladium Catalysts for Suzuki Coupling of 2,4-Dichloropyrimidine

Catalyst System	Base	Solvent	Temp (°C)	Time (h)	Yield (%)	Catalyst Loading (mol%)	Reference
Pd(PPh <sub>3</sub> ) <sub>4</sub>	K <sub>2</sub> CO <sub>3</sub>	1,4-Dioxane	100	24	71	5	
Pd(dppf)Cl <sub>2</sub>	K <sub>2</sub> CO <sub>3</sub>	1,4-Dioxane	100	24	55	5	[11]
XPhos Pd G3	K <sub>3</sub> PO <sub>4</sub>	1,4-Dioxane	100	2	95	2	[7]
PEPPSI-IPr	K <sub>3</sub> PO <sub>4</sub>	1,4-Dioxane	80	2	88	0.5	

## Guide 2: Enhancing Reactivity in Buchwald-Hartwig Amination

For challenging Buchwald-Hartwig aminations of unreactive chloropyrimidines, particularly with less nucleophilic amines, optimization of the catalytic system is key.

Step-by-Step Troubleshooting Protocol:

- Ligand Selection: The choice of ligand is paramount.
  - For primary amines: Start with ligands like BrettPhos.
  - For secondary amines: RuPhos is a good initial choice.
  - For challenging couplings (e.g., heteroaryl amines): Consider more specialized ligands like tBuBrettPhos or DavePhos.[12]

- Base Selection: Strong, non-nucleophilic bases are typically used.
  - Common choices include NaOtBu, KOtBu, and LiHMDS. Be cautious as some substrates may be sensitive to strong bases.[13]
- Solvent Choice: Anhydrous, degassed solvents are crucial.
  - Toluene, dioxane, and THF are commonly used.
- Catalyst Precursor:
  - Using a pre-formed Pd(0) source like Pd<sub>2</sub>(dba)<sub>3</sub> can be beneficial. Pd(OAc)<sub>2</sub> is also a common choice.

Data Presentation: Ligand Screening for the Buchwald-Hartwig Amination of 2-Chloro-4-phenylpyrimidine with Aniline

Ligand	Base	Solvent	Temp (°C)	Time (h)	Yield (%)	Reference
PPh <sub>3</sub>	NaOtBu	Toluene	100	24	<10	[14]
BINAP	NaOtBu	Toluene	100	18	45	[15]
XPhos	NaOtBu	Toluene	100	4	92	[14]
RuPhos	K <sub>3</sub> PO <sub>4</sub>	Dioxane	110	12	88	[12]

## Guide 3: Activating Pyrimidines via N-Oxide Formation for Nucleophilic Substitution

Formation of a pyrimidine N-oxide can significantly activate the ring towards nucleophilic attack, particularly at the C2 and C6 positions.[16]

Experimental Protocol: N-Oxidation of a Pyrimidine Derivative

- Reagent: A peroxy acid such as meta-chloroperoxybenzoic acid (m-CPBA) or hydrogen peroxide in acetic acid is typically used.[16]

- Procedure:
  - Dissolve the pyrimidine substrate in a suitable solvent (e.g., dichloromethane, chloroform, or acetic acid).
  - Cool the solution in an ice bath.
  - Add the oxidizing agent (e.g., m-CPBA) portion-wise, monitoring the reaction by TLC.
  - Stir the reaction at room temperature until completion.
  - Work-up involves quenching the excess oxidizing agent and purifying the N-oxide product.

Diagram: Activation of Pyrimidine via N-Oxide Formation

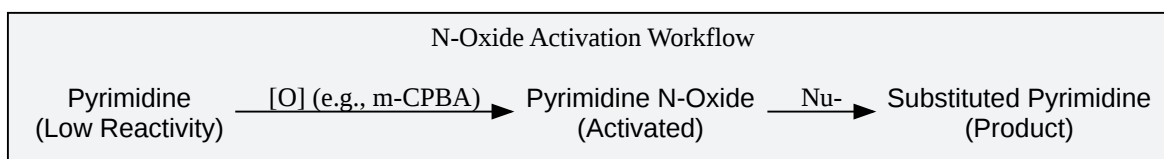

[Click to download full resolution via product page](#)

Caption: Workflow for activating pyrimidines using N-oxidation.

## Experimental Protocols

### Protocol 1: General Procedure for Suzuki-Miyaura Coupling of 2,4-Dichloropyrimidine[8]

- Reaction Setup: In an oven-dried reaction vessel, combine 2,4-dichloropyrimidine (1.0 mmol), the desired boronic acid (1.1 mmol), and the base (e.g.,  $K_2CO_3$ , 3.0 mmol).
- Catalyst Addition: Add the palladium catalyst (e.g.,  $Pd(PPh_3)_4$ , 0.05 mmol, 5 mol%).
- Solvent Addition: Add the degassed solvent (e.g., 1,4-dioxane, 5 mL).

- Reaction: Stir the mixture under an inert atmosphere (e.g., argon or nitrogen) at the desired temperature (e.g., 100 °C) and monitor the reaction progress by TLC or GC/MS.
- Work-up: After completion, cool the reaction to room temperature, dilute with an organic solvent (e.g., ethyl acetate), and wash with water and brine. Dry the organic layer over anhydrous Na<sub>2</sub>SO<sub>4</sub>, filter, and concentrate under reduced pressure.
- Purification: Purify the crude product by column chromatography on silica gel.

## Protocol 2: General Procedure for Buchwald-Hartwig Amination of a Chloropyrimidine[12]

- Reaction Setup: In a glovebox or under a stream of inert gas, add the chloropyrimidine (1.0 mmol), the amine (1.2 mmol), the palladium precatalyst (e.g., Pd<sub>2</sub>(dba)<sub>3</sub>, 0.01 mmol, 1 mol%), the ligand (e.g., XPhos, 0.024 mmol, 2.4 mol%), and the base (e.g., NaOtBu, 1.4 mmol) to an oven-dried reaction vial.
- Solvent Addition: Add anhydrous, degassed solvent (e.g., toluene, 5 mL).
- Reaction: Seal the vial and heat the reaction mixture with stirring at the desired temperature (e.g., 100 °C) until the starting material is consumed as indicated by TLC or LC/MS.
- Work-up: Cool the reaction to room temperature, dilute with an organic solvent, and filter through a pad of celite. Wash the filtrate with water and brine, dry the organic layer, and concentrate.
- Purification: Purify the product by flash column chromatography.

## References

- One-pot Double Suzuki Couplings of Dichloropyrimidines. PMC.
- A Comparative Guide to Palladium Catalysts for Suzuki Coupling of Chloropyrimidines. Benchchem.
- Direct C–H Arylation of Electron-Deficient Heterocycles with Arylboronic Acids. PMC.
- Application Notes and Protocols for Suzuki Coupling Reactions with 2-Ethoxy-4,6-dichloropyrimidine. Benchchem.
- A Highly Regioselective Amination of 6-Aryl-2,4-dichloropyrimidine. Organic Letters.
- Exploring Homogeneous Conditions for Mild Buchwald-Hartwig Amination in B

- Microwave-Assisted Regioselective Suzuki Coupling of 2,4-Dichloropyrimidines with Aryl and Heteroaryl Boronic Acids. Semantic Scholar.
- Yields of 27 obtained during optimisation of the Buchwald- Hartwig coupling of 24 with aniline.
- Understanding the highly variable Regioselectivity in SNAr reaction of Dichloropyrimidines. Schrödinger.
- Comparative yields for Suzuki-Miyaura couplings of (A)...
- Copper-Catalyzed C–H Arylation of Fused-Pyrimidinone Derivatives Using Diaryliodonium Salts.
- Protecting Groups for Boronic Acids.
- The first Pd-catalyzed Buchwald–Hartwig aminations at C-2 or C-4 in the estrone series. ScienceDirect.
- Suzuki–Miyaura Reactions of (4-bromophenyl)
- (PDF) ChemInform Abstract: Direct C-H Arylation of Electron-Deficient Heterocycles with Arylboronic Acids.
- Mild addition of nucleophiles to pyridine-N-oxides. PubMed.
- Direct C-H arylation of electron-deficient heterocycles with arylboronic acids. PubMed - NIH.
- Pyrimidine as an Aryl C-H Activ
- The Asymmetric Buchwald–Hartwig Amin
- A Highly Active Catalyst for Suzuki-Miyaura Cross-Coupling Reactions of Heteroaryl Compounds. Organic Chemistry Portal.
- Buchwald-Hartwig Amin
- Pyridine N-oxides are reactive towards both electrophilic and nucleophilic substitution. Clayden's Organic Chemistry.
- Synthesis of pyrimidines from dinitrogen and carbon. Oxford Academic.
- New Catalysts for Suzuki–Miyaura Coupling Reactions of Heteroatom-Substituted Heteroaryl Chlorides. The Journal of Organic Chemistry.
- Suzuki Coupling. Suzuki-Miyaura Reaction: Mechanism, Experimental Procedure, and Set Up. YouTube.
- Pyrimidine Metabolism Pathways Synthesis and Degradation.
- Arylation of Halogenated Pyrimidines via a Suzuki Coupling Reaction.
- HIGH-THROUGHPUT EXPERIMENTATION OF THE BUCHWALD- HARTWIG AMINATION FOR REACTION SCOUTING AND GUIDED SYNTHESIS. University of South Carolina.
- De Novo Pyrimidine Synthesis. BOC Sciences.
- Exp 4 - Suzuki Coupling Reaction | PDF. Scribd.
- Chemical Insights | How to Wisely Design Conditions for Buchwald-Hartwig Couplings ? . WuXi AppTec.
- US20140330008A1 - Process for the preparation of boronic acid intermediates.

- Current Chemistry Letters Synthesis, reactions, and applications of pyrimidine deriv
- Microwave-Assisted Regioselective Suzuki Coupling of 2,4-Dichloropyrimidines with Aryl and Heteroaryl Boronic Acids. MDPI.
- HELP: Purifying boronic acids sucks. r/OrganicChemistry - Reddit.
- The Boekelheide Rearrangement of Pyrimidine N-oxides as a Case Study of Closed or Open Shell Reactions. Refubium - Freie Universität Berlin.
- Studies on the Regioselective Nucleophilic Aromatic Substitution (S<sub>N</sub>Ar) Reaction of 2-Substituted 3,5-Dichloropyrazines | Request PDF.
- Protocol for Nucleophilic Substitution on the Pyridine Ring: Application Notes for Researchers and Drug Development Professional. Benchchem.
- Pyridine N-Oxides. Baran Lab.
- Dichotomy in Regioselectivity of S<sub>N</sub>Ar Reactions with 2-MeSO<sub>2</sub>-4-Chloropyrimidine. Schrödinger.
- Literature examples of Suzuki–Miyaura cross-coupling reactions of... | Download Scientific Diagram.
- (PDF) SYNTHESIS OF PYRIMIDINES AND ITS BIO- EVALUATION.
- S<sub>N</sub>Ar Reactions on 2-Amino-4,6-dichloropyrimidine-5-carbaldehyde. MDPI.
- Troubleshooting low yield in Suzuki coupling with 2-Chloropyridine-3-boronic acid. Benchchem.
- Boronic Acids as Prospective Inhibitors of Metallo-β-Lactamases: Efficient Chemical Reaction in the Enzymatic Active Site Revealed by Molecular Modeling. PMC.
- Simple pyrimidines. Part XIII. The formation and hydrolysis of simple potassium pyrimidinesulphonates. Journal of the Chemical Society B: Physical Organic (RSC Publishing).

### Need Custom Synthesis?

BenchChem offers custom synthesis for rare earth carbides and specific isotopic labeling.

Email: [info@benchchem.com](mailto:info@benchchem.com) or [Request Quote Online](#).

## Sources

- [1. pdf.benchchem.com \[pdf.benchchem.com\]](https://pdf.benchchem.com)
- [2. hammer.purdue.edu \[hammer.purdue.edu\]](https://hammer.purdue.edu)
- [3. Boronic Acids as Prospective Inhibitors of Metallo-β-Lactamases: Efficient Chemical Reaction in the Enzymatic Active Site Revealed by Molecular Modeling - PMC](#)

[[pmc.ncbi.nlm.nih.gov](https://pubmed.ncbi.nlm.nih.gov)]

- 4. [wuxibiology.com](https://wuxibiology.com) [[wuxibiology.com](https://wuxibiology.com)]
- 5. [pubs.acs.org](https://pubs.acs.org) [[pubs.acs.org](https://pubs.acs.org)]
- 6. Direct C–H Arylation of Electron-Deficient Heterocycles with Arylboronic Acids - PMC [[pmc.ncbi.nlm.nih.gov](https://pubmed.ncbi.nlm.nih.gov)]
- 7. A Highly Active Catalyst for Suzuki-Miyaura Cross-Coupling Reactions of Heteroaryl Compounds [[organic-chemistry.org](https://organic-chemistry.org)]
- 8. One-pot Double Suzuki Couplings of Dichloropyrimidines - PMC [[pmc.ncbi.nlm.nih.gov](https://pubmed.ncbi.nlm.nih.gov)]
- 9. Microwave-Assisted Regioselective Suzuki Coupling of 2,4-Dichloropyrimidines with Aryl and Heteroaryl Boronic Acids [[mdpi.com](https://mdpi.com)]
- 10. Protecting Groups for Boronic Acids | Chem-Station Int. Ed. [[en.chem-station.com](https://en.chem-station.com)]
- 11. [pdfs.semanticscholar.org](https://pdfs.semanticscholar.org) [[pdfs.semanticscholar.org](https://pdfs.semanticscholar.org)]
- 12. [chem.libretexts.org](https://chem.libretexts.org) [[chem.libretexts.org](https://chem.libretexts.org)]
- 13. Chemical Insights | How to Wisely Design Conditions for Buchwald-Hartwig Couplings ? - RCS Research Chemistry Services [[rcs.wuxiapptec.com](https://rcs.wuxiapptec.com)]
- 14. BJOC - The first Pd-catalyzed Buchwald–Hartwig aminations at C-2 or C-4 in the estrone series [[beilstein-journals.org](https://beilstein-journals.org)]
- 15. [xingweili.snnu.edu.cn](https://xingweili.snnu.edu.cn) [[xingweili.snnu.edu.cn](https://xingweili.snnu.edu.cn)]
- 16. Pyridine N-oxides are reactive towards both electrophilic and nucleophilic substitution [[ns1.almerja.com](https://ns1.almerja.com)]
- To cite this document: BenchChem. [Technical Support Center: Troubleshooting Low Reactivity of Pyrimidine Derivatives]. BenchChem, [2026]. [Online PDF]. Available at: [<https://www.benchchem.com/product/b13140464/docs#technical-support-center-troubleshooting-low-reactivity-of-pyrimidine-derivatives>]

---

### Disclaimer & Data Validity:

The information provided in this document is for Research Use Only (RUO) and is strictly not intended for diagnostic or therapeutic procedures. While BenchChem strives to provide accurate protocols, we make no warranties, express or implied, regarding the fitness of this product for every specific experimental setup.

**Technical Support:** The protocols provided are for reference purposes. Unsure if this reagent suits your experiment?

**Need Industrial/Bulk Grade?** [Request Custom Synthesis Quote](#)

## BenchChem

Our mission is to be the trusted global source of essential and advanced chemicals, empowering scientists and researchers to drive progress in science and industry.

### Contact

Address: 3281 E Guasti Rd  
Ontario, CA 91761, United States  
Phone: (601) 213-4426  
Email: [info@benchchem.com](mailto:info@benchchem.com)

[Contact our Ph.D. Support Team for a compatibility check](#)