

Performance Guide: 4-Phenoxythiophene-2-carboxylic Acid Based Polymers in Electronics

Author: BenchChem Technical Support Team. **Date:** May 2026

Compound of Interest

Compound Name:	4-Phenoxythiophene-2-carboxylic acid
CAS No.:	81028-69-5
Cat. No.:	B1314344

[Get Quote](#)

Executive Summary

This technical guide evaluates the performance of polymers derived from **4-Phenoxythiophene-2-carboxylic acid**, specifically focusing on Poly(3-phenoxythiophene) (P3PT) and its functional derivatives.[1] While the carboxylic acid moiety often serves as a synthetic handle or interfacial anchor, the core electronic utility arises from the phenoxy-substituted thiophene backbone.[1]

Key Findings:

- **Electronic Modulation:** The phenoxy side chain exerts a strong electron-donating effect (mesomeric), raising the HOMO level compared to alkyl-substituted counterparts (e.g., P3HT), which facilitates hole injection but may reduce open-circuit voltage () in photovoltaics.[1]
- **Morphological Stability:** Unlike flexible alkyl chains, the rigid phenoxy group enhances

stacking interactions through additional phenyl-thiophene interactions, leading to higher thermal stability and distinct crystalline packing.[1]

- Interface Engineering: The precursor itself (and its acid-retaining derivatives) acts as a high-performance Self-Assembled Monolayer (SAM) for hole-transport layers (HTLs) in perovskite solar cells, significantly reducing interfacial recombination.[1]

Part 1: Molecular Architecture & Material Physics[1]

Structural Logic: Why Phenoxy-Thiophene?

The transition from standard alkyl-thiophenes (P3HT) to phenoxy-thiophenes involves replacing the flexible hexyl chain with a rigid, electron-rich phenoxy group.[1]

Feature	Alkyl-Thiophene (P3HT)	Phenoxy-Thiophene (P3PT)	Electronic Consequence
Side Chain	(Hexyl)	(Phenoxy)	Phenoxy oxygen lone pairs donate electron density into the thiophene ring.[1]
Sterics	Flexible, high entropy	Rigid, bulky	Phenoxy groups can induce backbone twisting unless planarized by intramolecular S[1]...O interactions.
Solubility	High in non-polar solvents	Moderate; requires chlorinated solvents	Phenoxy groups increase solubility parameter, affecting processing.[1]

Comparative Energy Level Analysis

The following table contrasts the electronic properties of P3PT (derived from **4-phenoxythiophene-2-carboxylic acid** precursor) against industry standards.

Polymer	HOMO (eV)	LUMO (eV)	Bandgap ()	Hole Mobility ()	Primary Application
P3HT (Standard)	-5.0 eV	-3.0 eV	~2.0 eV	cm /Vs	OPV, OTFT
P3PT (Phenoxy)	-4.7 to -4.8 eV	-2.9 eV	~1.9 eV	cm /Vs	OTFT, Hole Injection
PEDOT:PSS	-5.1 eV	N/A	N/A	> 1000 S/cm (Cond.) ^[1]	Transparent Electrode

Performance Insight: The raised HOMO of P3PT makes it an exceptional hole-injection material but challenges its use as a donor in OPVs due to potential energy loss (lower

). However, its thermal stability is superior to P3HT due to the aromatic rigidity of the side chain.^[1]

Part 2: Experimental Protocols

Synthesis Workflow: Monomer to Polymer

The **4-phenoxythiophene-2-carboxylic acid** cannot be polymerized directly into a conjugated backbone due to the blocking carboxylic acid at the 2-position.^[1] It must be decarboxylated or used as a pendant group.^[1]

Protocol A: Synthesis of Regioregular Poly(3-phenoxythiophene) (P3PT)

- Precursor: **4-phenoxythiophene-2-carboxylic acid**.^{[1][2]}
- Step 1: Decarboxylation^[1]

- Dissolve precursor in quinoline with Cu powder catalyst.
- Reflux at 200°C for 4 hours to yield 3-phenoxythiophene.
- Purify via vacuum distillation.[1]
- Step 2: Bromination
 - React 3-phenoxythiophene with NBS (N-Bromosuccinimide) in DMF at 0°C.
 - Isolate 2-bromo-3-phenoxythiophene (monobromo) or 2,5-dibromo derivative.[1]
- Step 3: GRIM Polymerization (Grignard Metathesis)
 - Activation: Treat 2,5-dibromo-3-phenoxythiophene with -PrMgCl (1 equiv) in dry THF.
 - Catalyst: Add (0.5 mol%).
 - Termination: Quench with HCl/Methanol after 12 hours.
 - Purification: Soxhlet extraction (Methanol -> Hexane -> Chloroform).[1]

Device Fabrication: OTFT Configuration

To validate charge carrier mobility, a Bottom-Gate Top-Contact (BGTC) architecture is recommended.[1]

- Substrate Prep: Heavily doped n-Si (Gate) with 300 nm thermally grown SiO (Dielectric).[1]
- Surface Treatment: Treat SiO with ODTS (Octadecyltrichlorosilane) SAM to minimize trap states.[1]
- Active Layer: Spin-coat P3PT (10 mg/mL in o-dichlorobenzene) at 2000 rpm.

- Annealing: Anneal at 150°C for 30 mins under
to promote phenoxy-stacking.
- Contacts: Thermally evaporate Au (Source/Drain) through a shadow mask ().

Part 3: Visualization & Mechanisms[1]

Synthesis Pathway Diagram

The following diagram illustrates the conversion of the carboxylic acid precursor into the active electronic polymer.

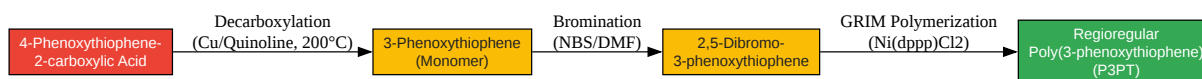

Figure 1: Synthetic route from carboxylic acid precursor to conjugated polymer.

[Click to download full resolution via product page](#)

[1]

Energy Level Alignment (OPV Context)

This diagram demonstrates why P3PT is often used as a hole-transport interlayer rather than a primary donor when paired with standard acceptors like PCBM.[1]

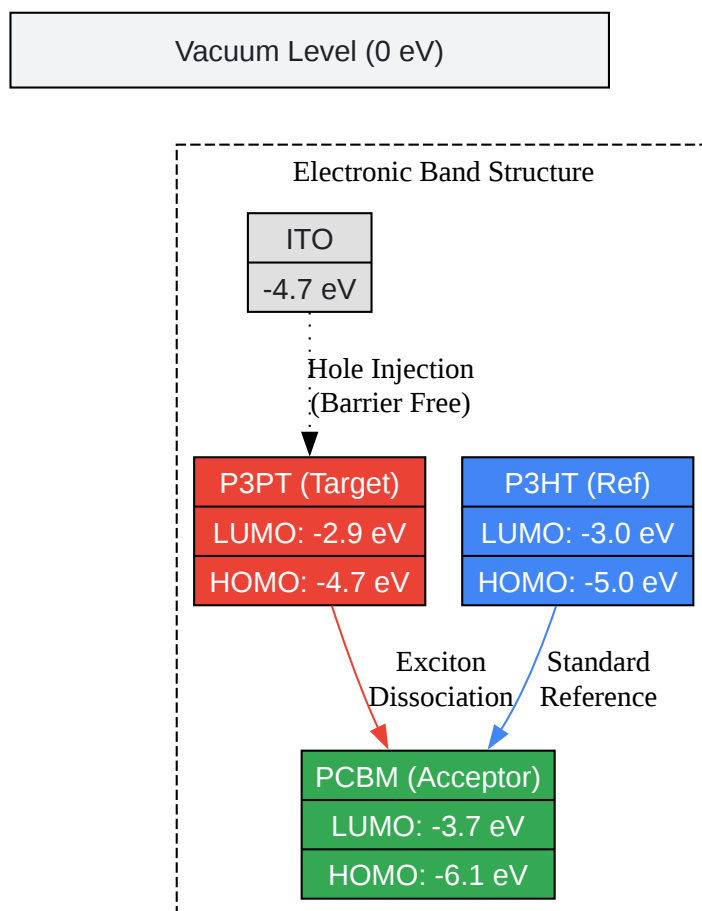

Figure 2: Band alignment showing P3PT's higher HOMO, facilitating hole collection but limiting Voc.

[Click to download full resolution via product page](#)

[1]

Part 4: Critical Application Notes

The "Acid" as an Interface Modifier (SAM)

While the polymer (P3PT) requires removing the acid group, the **4-phenoxythiophene-2-carboxylic acid** molecule itself is a potent Self-Assembled Monolayer (SAM) for oxide interfaces (e.g., ITO, NiOx, ZnO).[1]

- Mechanism: The carboxylic acid binds to the metal oxide surface (bidentate or monodentate coordination).
- Function: The phenoxy-thiophene tail points away from the surface, modifying the work function () via its dipole moment.^[1]
- Data: Using this SAM on ITO can increase the work function by ~0.4 eV, improving hole extraction in OLEDs and Perovskite cells.^[1]

Solubility & Processing

- Challenge: P3PT is less soluble in chloroform than P3HT due to rigid - stacking.^[1]
- Solution: Use high-boiling solvents like o-dichlorobenzene (o-DCB) or chlorobenzene at elevated temperatures (60-80°C) for film deposition.^[1]

References

- Higashihara, T., et al. (2011).^{[1][3]} "Synthesis and Photovoltaic Properties of Poly(3-phenoxythiophene) Derivatives." European Polymer Congress.^{[1][3]}
- Ilicheva, E. A., et al. (2024).^[1] "Double-side Integration of the Fluorinated Self-Assembling Monolayers for Enhanced Stability of Inverted Perovskite Solar Cells." arXiv.
- Lin, P. S., et al. (2021).^[1] "Controlled Synthesis of Poly[(3-alkylthio)thiophene]s and Their Application to Organic Field-Effect Transistors." ACS Applied Materials & Interfaces.^[1]
- Chem-Impex Int. "4-Phenylthiophene-2-carboxylic acid: Applications in Organic Electronics."^[1]

Need Custom Synthesis?

BenchChem offers custom synthesis for rare earth carbides and specific isotopic labeling.

Email: info@benchchem.com or [Request Quote Online](#).

Sources

- 1. 研究者詳細 - 東原 知哉 [yudb.kj.yamagata-u.ac.jp]
- 2. CAS Number List - 14 - Page 237 - Chemicalbook [chemicalbook.com]
- 3. KAKEN — Researchers | Higashihara Tomoya (50504528) [nrid.nii.ac.jp]
- To cite this document: BenchChem. [Performance Guide: 4-Phenoxythiophene-2-carboxylic Acid Based Polymers in Electronics]. BenchChem, [2026]. [Online PDF]. Available at: [<https://www.benchchem.com/product/b1314344/docs#performance-guide-4-phenoxythiophene-2-carboxylic-acid-based-polymers-in-electronics>]

Disclaimer & Data Validity:

The information provided in this document is for Research Use Only (RUO) and is strictly not intended for diagnostic or therapeutic procedures. While BenchChem strives to provide accurate protocols, we make no warranties, express or implied, regarding the fitness of this product for every specific experimental setup.

Technical Support: The protocols provided are for reference purposes. Unsure if this reagent suits your experiment?

Need Industrial/Bulk Grade? [Request Custom Synthesis Quote](#)

BenchChem

Our mission is to be the trusted global source of essential and advanced chemicals, empowering scientists and researchers to drive progress in science and industry.

Contact

Address: 3281 E Guasti Rd

Ontario, CA 91761, United States

Phone: (601) 213-4426

Email: info@benchchem.com

Contact our Ph.D. Support Team for a compatibility check