

Application Notes & Protocols: Microwave-Assisted Synthesis of Pyrazole Derivatives

Author: BenchChem Technical Support Team. **Date:** May 2026

Compound of Interest

Compound Name: *1-(1H-Pyrazol-1-yl)ethanone*

CAS No.: 10199-64-1

Cat. No.: B161398

[Get Quote](#)

For Researchers, Scientists, and Drug Development Professionals

Introduction

Pyrazoles are a pivotal class of five-membered nitrogen-containing heterocyclic compounds, forming the core structure of numerous pharmaceuticals.^[1] Derivatives of pyrazole are of paramount interest in drug discovery due to their broad spectrum of biological activities, including anticancer, anti-inflammatory, antimicrobial, and analgesic properties.^{[1][2]} Several FDA-approved drugs, such as the anti-inflammatory celecoxib and various tyrosine kinase inhibitors used in cancer therapy, feature a pyrazole scaffold.^{[1][3]}

Microwave-assisted synthesis has emerged as a powerful and green tool in medicinal chemistry, enabling the rapid and efficient synthesis of compound libraries for screening.^{[1][4]} This technology offers significant advantages over conventional heating methods.

Key Advantages of Microwave-Assisted Synthesis:

- **Speed:** Reaction times are often dramatically reduced from hours to mere minutes.^{[1][3]}

- Yield: Increased reaction efficiency frequently leads to higher product yields.[1][3]
- Purity: Cleaner reactions can simplify product purification processes.[1]
- Green Chemistry: Reduced energy consumption and the potential for solvent-free reactions contribute to more sustainable laboratory practices.[4][5]

These application notes provide detailed protocols for the microwave-assisted synthesis of various pyrazole derivatives, including data presentation comparing microwave and conventional methods, and visualizations of the experimental workflow.

Data Presentation: Microwave vs. Conventional Synthesis

The following tables summarize quantitative data from the literature, comparing microwave-assisted synthesis with conventional heating methods for the preparation of various pyrazole derivatives.

Table 1: Synthesis of Phenyl-1H-pyrazoles[1]

Product	Method	Temperature (°C)	Time	Yield (%)
Phenyl-1H-pyrazoles	Microwave-Assisted	60	5 min	91-98
Phenyl-1H-pyrazoles	Conventional Heating	75	2 hours	73-90

Table 2: Synthesis of Pyrazole-Oxadiazole Hybrids[1]

Product	Method	Time	Yield (%)
Pyrazole-Oxadiazole Hybrids	Microwave-Assisted	9-10 min	79-92
Pyrazole-Oxadiazole Hybrids	Conventional Heating	7-9 hours	Not Specified

Table 3: Synthesis of Quinolin-2(1H)-one-based Pyrazoles[3]

Product	Method	Power (W)	Temperature (°C)	Time	Yield (%)
Quinolin-2(1H)-one-based Pyrazoles	Microwave-Assisted	360	120	7-10 min	68-86

Table 4: Multi-component Synthesis of Pyrazol-5-ol Derivatives[6][7]

Catalyst	Method	Power (W)	Time	Solvent	Yield (%)
Graphene Oxide (0.05 wt%)	Microwave-Assisted	180	4 min	Water	95
None	Microwave-Assisted	180	15-35 min	Various Polar Solvents	21-95

Experimental Protocols

Protocol 1: Synthesis of Pyrazoles from Chalcones

This protocol describes the synthesis of pyrazole derivatives from chalcone precursors using microwave irradiation.[1]

Materials:

- Chalcone (1.0 mmol)
- Hydrazine derivative (e.g., hydrazine hydrate, phenylhydrazine) (1.2 mmol)
- Ethanol (5 mL)
- Glacial Acetic Acid (catalytic amount)

- Microwave reactor vial with a stir bar
- Microwave reactor
- Standard laboratory glassware for filtration and recrystallization

Procedure:

- In a microwave reactor vial equipped with a stir bar, combine the chalcone (1.0 mmol) and the hydrazine derivative (1.2 mmol).
- Add ethanol (5 mL) and a catalytic amount of glacial acetic acid.
- Seal the vial and place it in the microwave reactor.
- Irradiate the reaction mixture at a specified power and time (e.g., 300 W for 1-5 minutes).[1]
The reaction progress can be monitored by thin-layer chromatography (TLC).
- After the reaction is complete, cool the vial to room temperature.
- Pour the reaction mixture into crushed ice.
- Collect the resulting precipitate by vacuum filtration.
- Wash the solid with cold water and recrystallize from a suitable solvent (e.g., ethanol) to afford the pure pyrazole derivative.[1]

Protocol 2: Solvent-Free Synthesis of Pyrazolones from β -Ketoesters

This protocol outlines a green, solvent-free approach to synthesizing pyrazolone derivatives from β -ketoesters and hydrazines under microwave irradiation.[5]

Materials:

- β -ketoester (e.g., ethyl acetoacetate)
- Substituted or unsubstituted hydrazine

- Domestic microwave oven
- Reaction vessel (e.g., beaker or flask)

Procedure:

- In an open Erlenmeyer flask, take a mixture of the β -ketoester and the substituted or unsubstituted hydrazine.
- Place the flask in a domestic microwave oven.
- Irradiate the mixture. The power and time of irradiation will need to be optimized for the specific reactants.
- The reaction proceeds rapidly, often within minutes.
- Allow the reaction mixture to cool to room temperature.
- The crude product can be further purified by recrystallization.[1]

Protocol 3: Multi-component Synthesis of Pyranopyrazoles

This protocol describes a one-pot, multi-component synthesis of pyranopyrazole derivatives under microwave irradiation.[8]

Materials:

- Pyrazolone derivative (e.g., 3-methyl-1-phenyl-2-pyrazolin-5-one)
- Aromatic aldehyde
- Malononitrile
- Dry Ethanol
- Piperidine (catalytic amount)

- Microwave reactor

Procedure:

- In a reaction vessel suitable for microwave synthesis, combine the pyrazolone derivative, aromatic aldehyde, and malononitrile in dry ethanol.
- Add a catalytic amount of piperidine.
- Place the vessel in the microwave reactor.
- Irradiate the mixture for 2-8 minutes.[8]
- Upon completion, cool the reaction mixture.
- Pour the mixture into hot water to precipitate the product.[1]
- Collect the solid by filtration and purify by recrystallization.

Visualizations

General Workflow for Microwave-Assisted Pyrazole Synthesis

General Workflow for Microwave-Assisted Pyrazole Synthesis

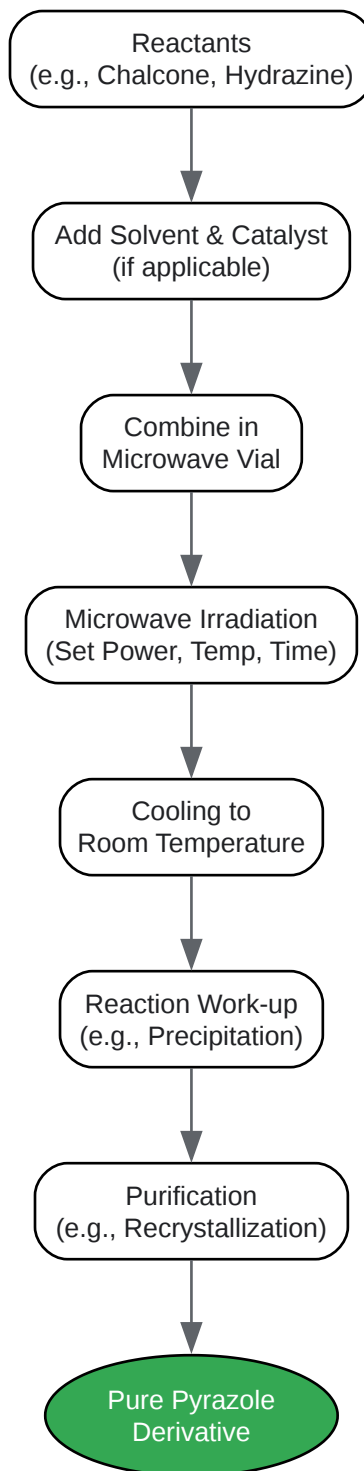

[Click to download full resolution via product page](#)

Caption: A generalized workflow for the synthesis of pyrazole derivatives using microwave technology.

Logical Relationship in Multi-Component Synthesis

Logical Flow of a Multi-Component Pyrazole Synthesis

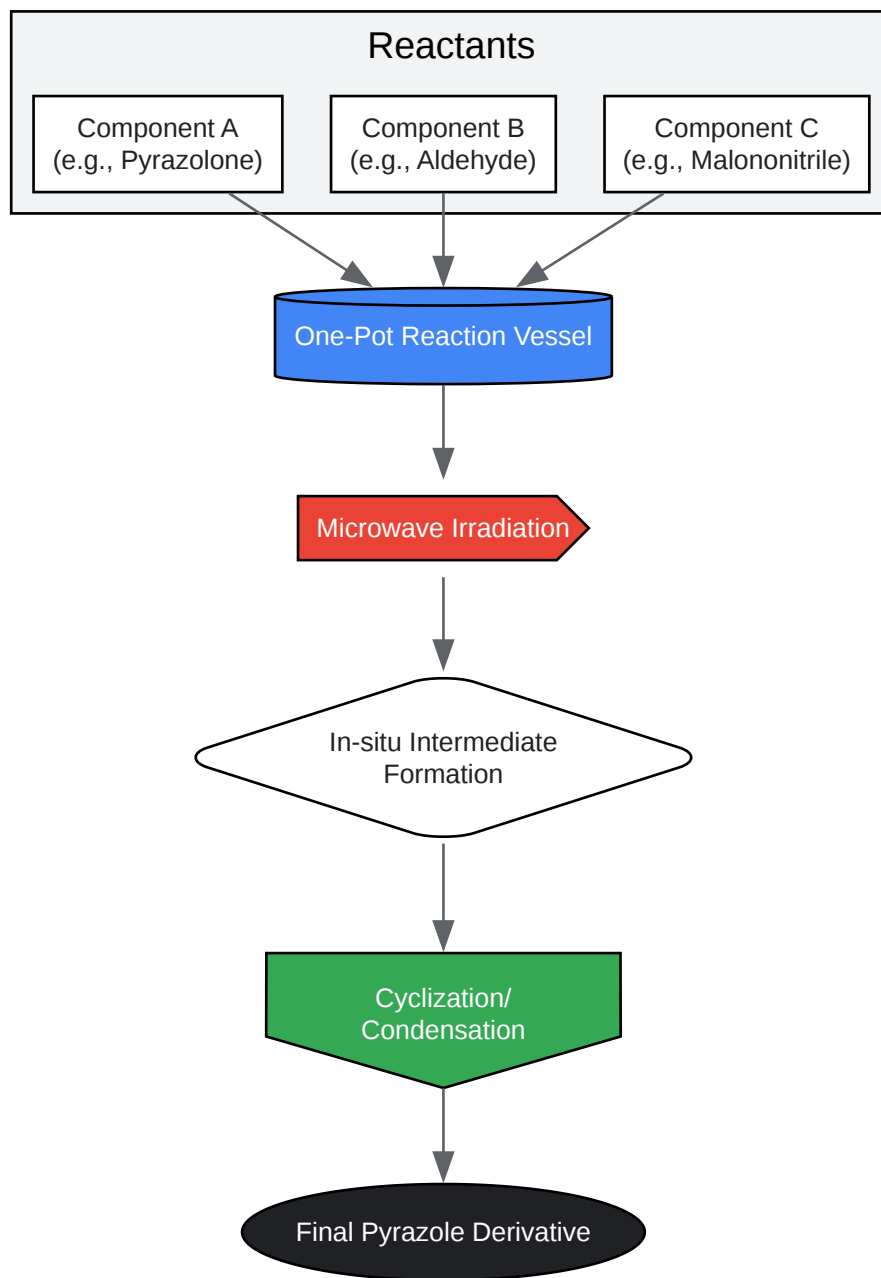

[Click to download full resolution via product page](#)

Need Custom Synthesis?

BenchChem offers custom synthesis for rare earth carbides and specific isotopic labeling.

Email: info@benchchem.com or [Request Quote Online](#).

References

- [1. benchchem.com \[benchchem.com\]](#)
- [2. benthamdirect.com \[benthamdirect.com\]](#)
- [3. Recent advances in the synthesis of anticancer pyrazole derivatives using microwave, ultrasound, and mechanochemical techniques - RSC Advances \(RSC Publishing\) DOI:10.1039/D4RA08866B \[pubs.rsc.org\]](#)
- [4. researchgate.net \[researchgate.net\]](#)
- [5. scielo.br \[scielo.br\]](#)
- [6. Microwave-assisted multi-component green synthesis of bioactive pyrazol-5-ol and its derivatives using graphene oxide as a recyclable catalyst: a route to EGFR inhibitors - RSC Advances \(RSC Publishing\) \[pubs.rsc.org\]](#)
- [7. Microwave-assisted multi-component green synthesis of bioactive pyrazol-5-ol and its derivatives using graphene oxide as a recyclable catalyst: a route to EGFR inhibitors - PMC \[pmc.ncbi.nlm.nih.gov\]](#)
- [8. gsconlinepress.com \[gsconlinepress.com\]](#)
- [To cite this document: BenchChem. \[Application Notes & Protocols: Microwave-Assisted Synthesis of Pyrazole Derivatives\]. BenchChem, \[2026\]. \[Online PDF\]. Available at: \[https://www.benchchem.com/product/b161398/docs#application-notes-protocols-microwave-assisted-synthesis-of-pyrazole-derivatives\]](#)

Disclaimer & Data Validity:

The information provided in this document is for Research Use Only (RUO) and is strictly not intended for diagnostic or therapeutic procedures. While BenchChem strives to provide accurate protocols, we make no warranties, express or implied, regarding the fitness of this product for every specific experimental setup.

Technical Support: The protocols provided are for reference purposes. Unsure if this reagent suits your experiment?

Need Industrial/Bulk Grade? [Request Custom Synthesis Quote](#)

BenchChem

Our mission is to be the trusted global source of essential and advanced chemicals, empowering scientists and researchers to drive progress in science and industry.

Contact

Address: 3281 E Guasti Rd

Ontario, CA 91761, United States

Phone: (601) 213-4426

Email: info@benchchem.com

[Contact our Ph.D. Support Team for a compatibility check](#)